



N421067A - Rev.00 - 03/2024

OKKI

First of all, we would like to thank you for having chosen one of our units.

As you will realise, you have made a winning choice by purchasing a product that represents the state of the art in domestic air-conditioning technology.

Thanks to the product you have purchased and by following the suggestions in this manual, you will benefit from optimal environmental conditions with the lowest possible energy investment.

Compliance

This unit complies with European directives:

- Low Voltage Directive 2014/35/EU by transposition of the following technical standards: EN 60335-1:2012 + EN 60335-2-40:2003
- EMC Directive 2014/30/EU, by transposition of technical standards: EN 55014-1:2017 + EN 55014-2:2015 + EN 61000-3-2:2014 + EN 61000 3-3:2013
- RoHS Directive 2011/65/EU by transposition of the following technical standards: EN 50581:2012
- European ErP Ecodesign Regulation No. 1254/2014

Markings



CONTENTS

1	General information	<u>p. 5</u>
1.1	About the manual	<u>p. 5</u>
1.2	General Warnings	<u>p. 6</u>
1.3	Basic safety rules	<u>p. 6</u>
1.4	Disposal.	<u>p. 7</u>
2	Product introduction	<u>p. 8</u>
2.1	Identification	<u>p. 8</u>
2.2	Destination of use	<u>p. 8</u>
2.3	Description of the appliance	<u>p. 8</u>
2.4	List of external components	<u>p. 9</u>
2.5	List of internal components	<u>p. 10</u>
2.6	Configurations	<u>p. 11</u>
2.7	Compatible accessories.	<u>p. 12</u>
3	Installation	<u>p. 13</u>
3.1	Preliminary Warnings	<u>p. 13</u>
3.2	Reception.	<u>p. 13</u>
3.3	Dimensions and weights with packaging.	<u>p. 13</u>
3.4	Handling with packaging	<u>p. 14</u>
3.5	Storage	<u>p. 14</u>
	Unpacking	<u>p. 14</u>
3.6	Handling without packaging	<u>p. 15</u>
3.7	Installation site.	<u>p. 15</u>
3.8	Minimum installation distances	<u>p. 16</u>
3.9	Positioning	<u>p. 18</u>
3.10	Refrigeration connections	<u>p. 19</u>
3.11	Condensate drain connection	<u>p. 22</u>
3.12	Aeraulic connections	<u>p. 24</u>
3.13	Electrical connections.	<u>p. 25</u>
4	Remote control	<u>p. 32</u>
4.1	Installation	<u>p. 32</u>
4.2	Electrical connections.	<u>p. 33</u>
4.3	Interface	<u>p. 34</u>
5	Start-up	<u>p. 35</u>
5.1	Preliminary Warnings	<u>p. 35</u>
5.2	First start-up	<u>p. 35</u>
5.3	Plant delivery.	<u>p. 37</u>
5.4	Switching off for extended periods	<u>p. 37</u>
5.5	External unit control	<u>p. 38</u>

6	Maintenance	<u>p. 40</u>
	Routine maintenance	<u>p. 40</u>
7	Faults and remedies	<u>p. 43</u>
7.1	Preliminary Warnings	<u>p. 43</u>
7.2	Anomalies reported by the control panel.	<u>p. 43</u>
7.3	Functional aspects not to be interpreted as faults.	<u>p. 43</u>
7.4	Troubleshooting Table	<u>p. 44</u>
7.5	Alarms displayed on the control panel of the external unit.	<u>p. 44</u>
8	Technical information	<u>p. 47</u>
8.1	Technical data	<u>p. 48</u>
8.2	Dimensions.	<u>p. 50</u>

GENERAL INFORMATION

1.1 About the manual

This manual was written to provide all the explanations for the correct management of the appliance.

- ⚠ This instruction manual is an integral part of the appliance and must therefore be kept in a safe place and must ALWAYS accompany the appliance even if it is passed on to another owner or user, or transferred to another plant. If it is damaged or lost, download a copy from the website.
- ⚠ Read this manual carefully before proceeding with any operation and follow the instructions in the individual chapters.
- ⚠ Specific warnings are given in each chapter of the document and should be read before starting operations.
- ⚠ The manufacturer accepts no liability for damage to persons or property resulting from failure to observe the regulations contained in this booklet.
- ⚠ This document is confidential under the terms of the law and may not be reproduced or passed on to third parties without the express authorisation of the company.

1.1.1 Editorial pictograms

The pictograms in the following chapter provide quick and unambiguous information necessary for the correct and safe use of the machine.

Related to safety

- ⚠ **High risk warning (bold text)**
 - The operation described above presents a risk of serious physical injury, fatality, major damage to the appliance and/or to the environment if not carried out in compliance with safety regulations.
- ⚠ Low risk warning (plain text)
 - The operation described above presents a risk of minor physical injury or minor damage to the appliance and/or to the environment if not carried out in compliance with safety regulations.
- 🚫 Prohibition (normal text)
 - Marks actions that absolutely must not be done.
- 📌 **Important information (bold text)**
 - This indicates important information that must be taken into account during the operations.

In the texts

Purpose of the actions

- Actions required

Expected responses following an action

- Lists

In the figures

- 1 The numbers indicate the individual components.
- A Capital letters indicate a combination of components and dimensions.
- ① The white numbers in black marks indicate a series of actions to be carried out in sequence.
- Ⓐ The black letter in white identifies an image when there are several images in the same figure.

Pictograms on the product

Symbols are used in some parts of the appliance:

Related to safety

⚠ Attention electrical hazard

- Warns relevant personnel of the presence of electricity and the risk of electric shock.

Recipients

User

Non-expert person capable of operating the product in safe conditions for people, for the product itself and the environment, interpreting an elementary diagnostic of faults and abnormal operating conditions, carrying out simple adjustment, checking and maintenance operations.

Installer

Expert person qualified to position and connect (hydraulically, electrically, etc.) the unit to the plant; this person is responsible for handling and correct installation according to the instructions provided in this manual and the national standards currently in force.

Service

Expert and qualified person authorised directly by the manufacturer to carry out all routine and supplementary maintenance operations, as well as every adjustment, check, repair and replacement of parts necessary during the life of the unit itself.

1.1.2 Organisation of the manual

The manual is divided into sections each dedicated to one or more target groups.

General information

It addresses all recipients.

It contains general information and important warnings that should be known before installing and using the appliance.

Product introduction

Addressed to all recipients, contains general information on the product.

Installation and Operation

It is addressed exclusively to the installer.

Contains specific warnings and all information necessary for positioning, mounting, connecting the device and operation.

Commissioning, maintenance and troubleshooting

They are addressed exclusively to the Technical Assistance Centre.

It contains specific warnings useful information for the most common commissioning and routine maintenance.

Technical information

It addresses all recipients.

It contains detailed technical information about the appliance.

1.2 General Warnings

- ⚠ Specific warnings are given in each chapter of the document and should be read before starting operations.
- ⚠ All personnel involved must be aware of the operations and dangers that may arise when beginning all unit installation operations.
- ⚠ Installation performed outside the warnings provided in this manual and use of the appliance outside the prescribed temperature limits will invalidate the warranty.
- ⚠ Any contractual or extra-contractual liability for damage caused to persons, animals or property, due to installation, adjustment and maintenance errors or improper use is excluded. All uses not expressly indicated in this manual are not permitted.
- ⚠ The installation of the appliances must be carried out by a qualified company which, on completion of the work, will issue a declaration of compliance to the person in charge of the plant in accordance with the regulations in force and the instructions provided in the instruction booklet accompanying the appliance.
- ⚠ First start-up and repair or maintenance operations must be carried out by the Technical Assistance Centre or by qualified personnel following the provisions of this manual.
- ⚠ Do not modify or tamper with the appliance as this can lead to dangerous situations.
- ⚠ Use suitable accident-prevention clothing and equipment during installation and/or maintenance operations. The manufacturer is not liable for the non-observance of the current safety and accident prevention regulations.
- ⚠ In the event of spillage of liquids, oil, set the system's main switch to "off" and close any water taps. Call the authorised Technical Assistance Centre or professionally qualified personnel as soon as possible and do not work on the appliance yourself.

- ⚠ When replacing components, use only original spare parts.
- ⚠ The manufacturer reserves the right to make changes to its models at any time to improve its product, without prejudice to the essential characteristics described in this manual. The manufacturer is not obliged to add such modifications to machines previously manufactured, already delivered or under construction.

1.2.1 Specific warnings for R32

- ⓘ **The document only contains some of the warnings regarding R32 refrigerant. For more comprehensive information, please read the safety data sheet available from the retailers.**
- ⚠ In each chapter, specific warnings are included for the operations described within. These warnings should be read before starting any activities.
- ⚠ All precautions regarding the handling of refrigerant must be followed in accordance with current regulations.
- ⚠ The unit uses environmentally-friendly R32 refrigerant, with a Global Warming Potential (GWP) of 675. Do not release R32 gas into the atmosphere.
- ⚠ The R32 refrigerant gas is slightly flammable and odorless.
- ⚠ Do not place flammable objects (spray cans) within 1 meter of the air discharge.
- ⚠ Avoid proximity to continuously operating ignition sources (open flames, gas appliances, electric stoves, lit cigarettes, etc.).
- ⚠ In case of refrigerant gas leakage, ventilate the area thoroughly and move away. Promptly call the authorized Technical Assistance Center or professionally qualified personnel and do not personally intervene on the appliance.

1.3 Basic safety rules

We would like to remind you that the use of products that use electricity and water involves observing certain basic safety precautions such as:

- ⚠ This appliance can be used by children aged 8 years and older and by persons with reduced physical, sensory, or mental capabilities, or lack of experience or knowledge, if they are supervised or have received instructions on the safe use of the appliance and understand the associated dangers. Children should not play with the appliance.
- ⚠ The cleaning and maintenance tasks intended to be carried out by the user should not be performed by children without supervision.

- ⚠ It is necessary to take precautions to prevent the room from having a backflow of gases from the flue or from other fuel-burning appliances.
- ⊖ It is forbidden for children and unassisted disabled persons to use the appliance.
- ⊖ It is forbidden to touch the appliance with wet or damp body parts.
- ⊖ It is forbidden to carry out any operation before disconnecting the appliance from the power supply by setting the plant master switch to "off".

- ⊖ It is forbidden to modify the safety or adjustment devices without the authorisation and instructions of the appliance manufacturer.
- ⊖ It is forbidden to pull, unplug or twist the electrical cables coming out of the appliance, even if it is disconnected from the mains supply.
- ⊖ It is forbidden to introduce objects and substances through the openings provided for the intake and delivery of air.
- ⊖ It is forbidden to open the access doors to the internal parts of the appliance without first setting the plant master switch to "off".
- ⊖ It is forbidden to dispose of packaging material and leave it within reach of children as it can be a potential source of danger.

1.4 Disposal

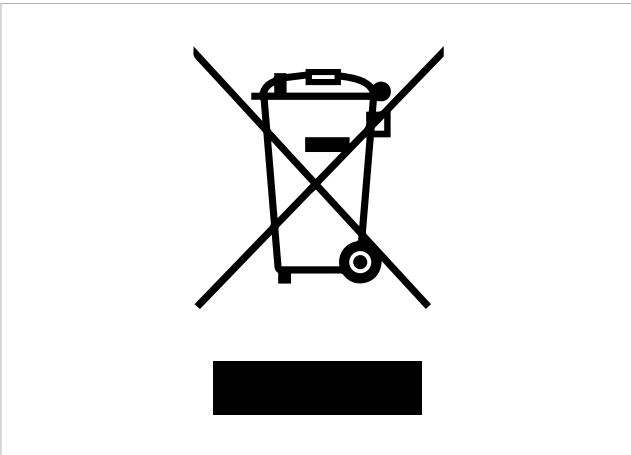

The symbol on the product or its packaging indicates that the product must not be treated as normal household waste, but must be taken to the appropriate collection point for the recycling of electrical and electronic equipment.

Proper disposal of this product avoids harm to humans and the environment and promotes the reuse of valuable raw materials.

For more detailed information about the recycling of this product, contact your local city office, your household waste disposal service or the shop where you purchased the product.

Illegal disposal of the product by the user involves the application of the administrative sanctions provided for by the regulations in force.

This provision is only valid in the EU Member States.

- ⚠ Avoid disassembling the appliance yourself.
- ⚠ **Contact an authorised Technical Assistance Centre to disassemble the appliance.**

PRODUCT INTRODUCTION

2.1 Identification

The appliance can be identified by the rating plate:

1. Technical rating plate

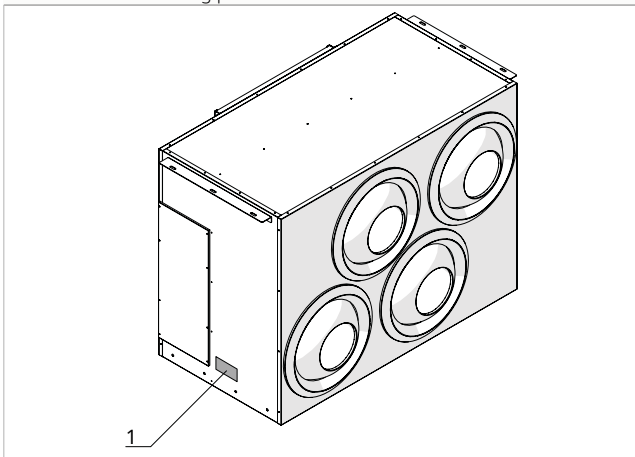

Technical rating plate

This shows the technical and performance specifications of the appliance.

⚠ Tampering with, removing or missing identification plates does not allow the product to be reliably identified by its serial number and therefore invalidates the warranty.

2.2 Destination of use

OKKI is a system designed for large spaces, such as industrial warehouses and extensive areas. An advanced solution that ensures maximum comfort and cost-effectiveness. It's equipped, on the indoor unit, with the SmartJet system: an innovative system with motorized and self-directing nozzles that autonomously and independently regulate the direction and temperature of the air to prevent stratification and ensure the maintenance of the desired temperature in the occupied area.

zles that autonomously and independently regulate the direction and temperature of the air to prevent stratification and ensure the maintenance of the desired temperature in the occupied area.

2.3 Description of the appliance

Structure: internally coated and galvanized sheet metal.

Brushless fans: radial fans with backward-facing blades.

Heat exchanger: air-to-air type made of copper-aluminum material.

Motorized nozzles: allow for the direction of airflow based on the temperature of the supplied air.

Filters: G2 flat metallic filters with all galvanized components

Models: 2 sizes with different flow rates are available.

Configurations: there are three different configurations available, which can be requested based on individual preferences.

- Smart jet configuration
- Manual jet configuration
- Ducted configuration

2.4 List of external components

- 1. Nozzle / Motorized nozzle
- 2. Electrical panel

- 3. Installation bracket

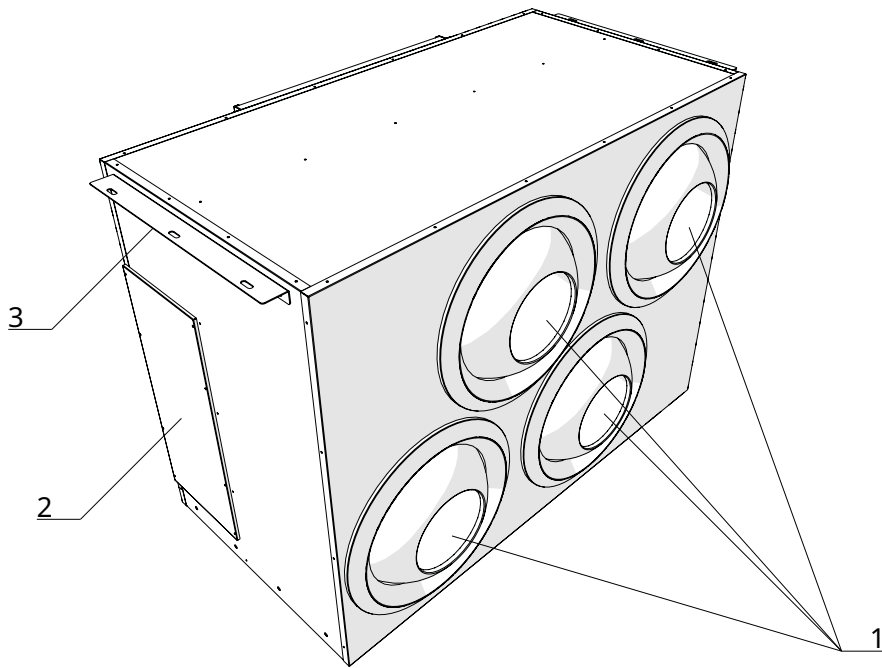

Size 30

- 1. External unit connection 3/4"
- 2. External unit connection 1/2"
- 3. Condensate drain

- 4. Extracted filter
- 5. Electrical connection passage

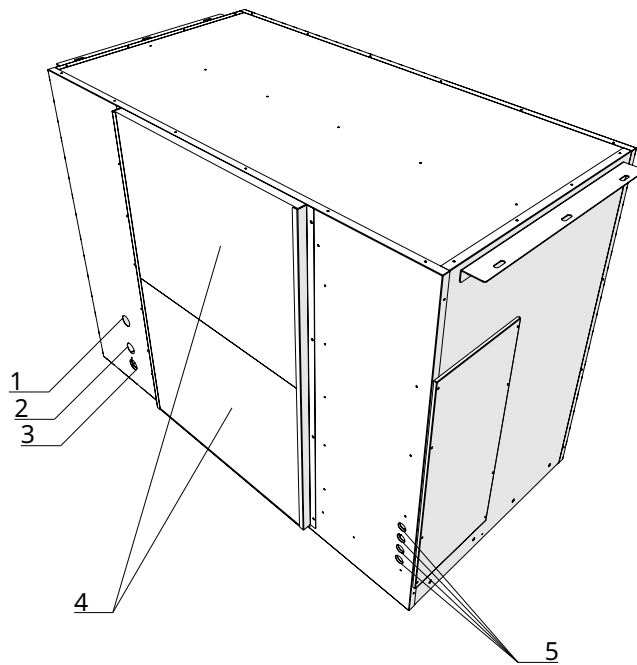

- 1. External unit connection 5/8"
- 2. External unit connection 3/8"
- 3. Condensate drain

- 4. Extracted filter
- 5. Electrical connection passage

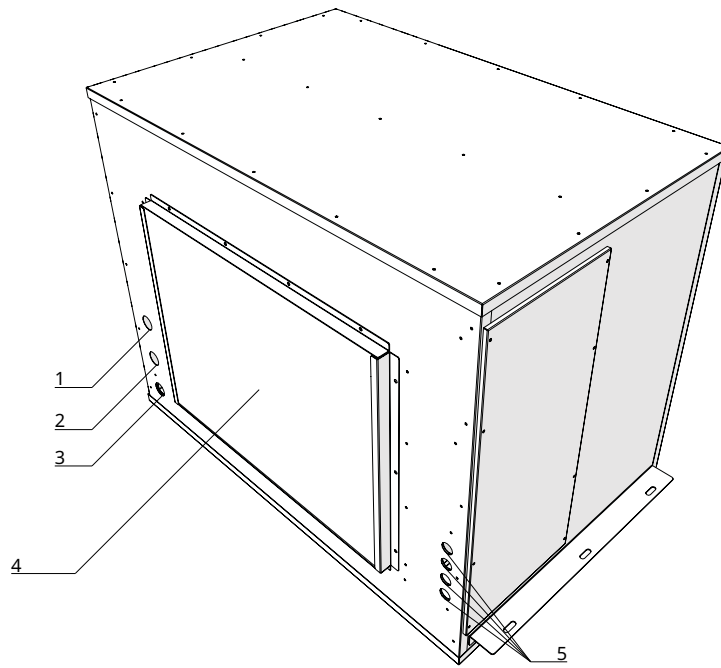

2.5 List of internal components

- 1. Fan

- 2. Heat exchanger

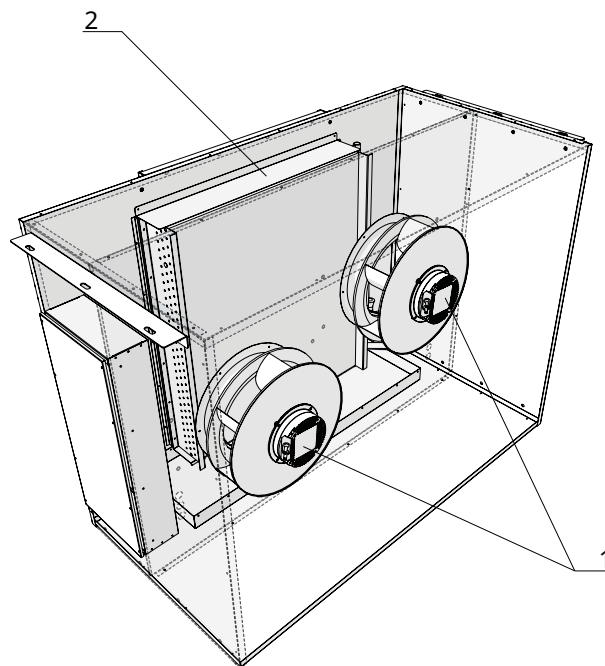

2.6 Configurations

A Smart jet configuration
B Manual jet configuration

C Ducted configuration

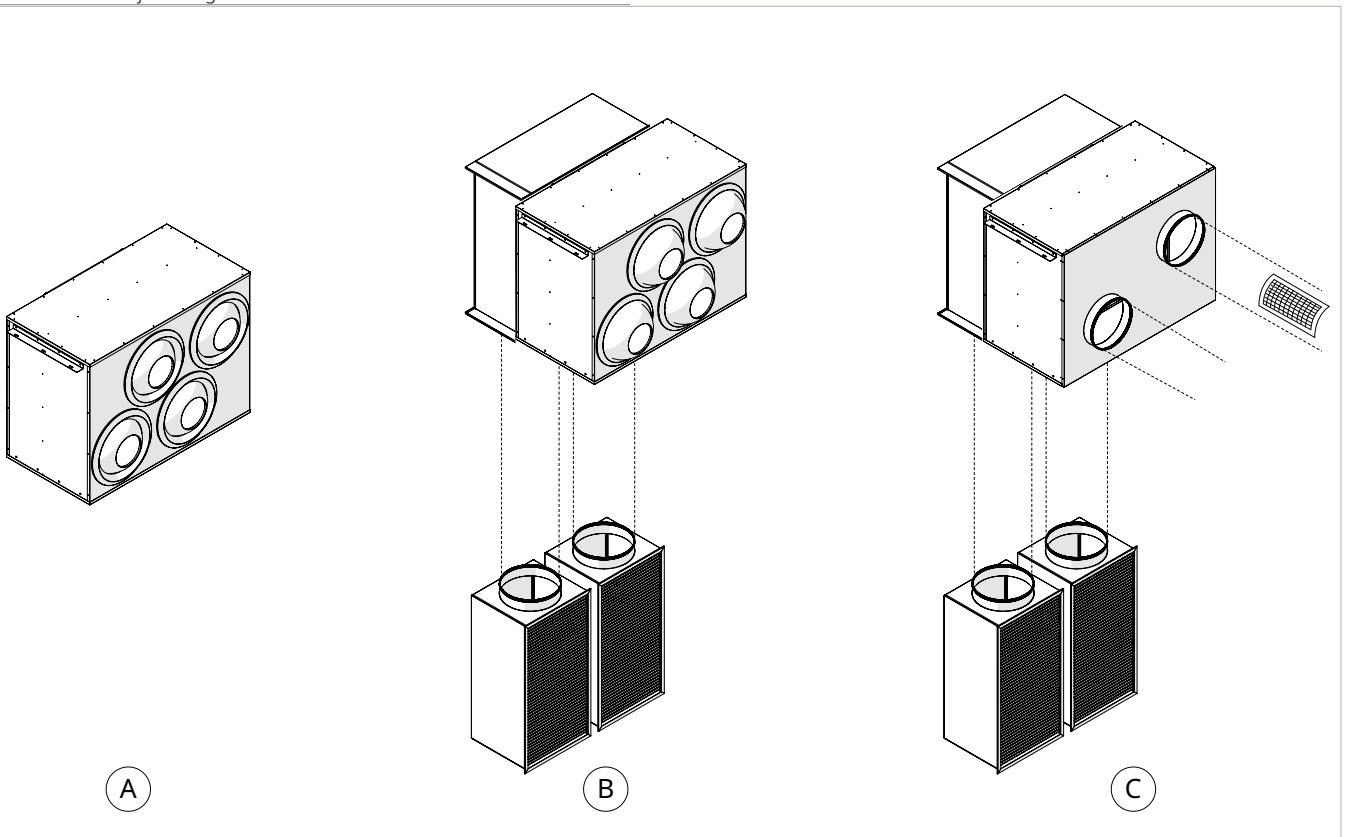

A Smart jet configuration
B Manual jet configuration

C Ducted configuration

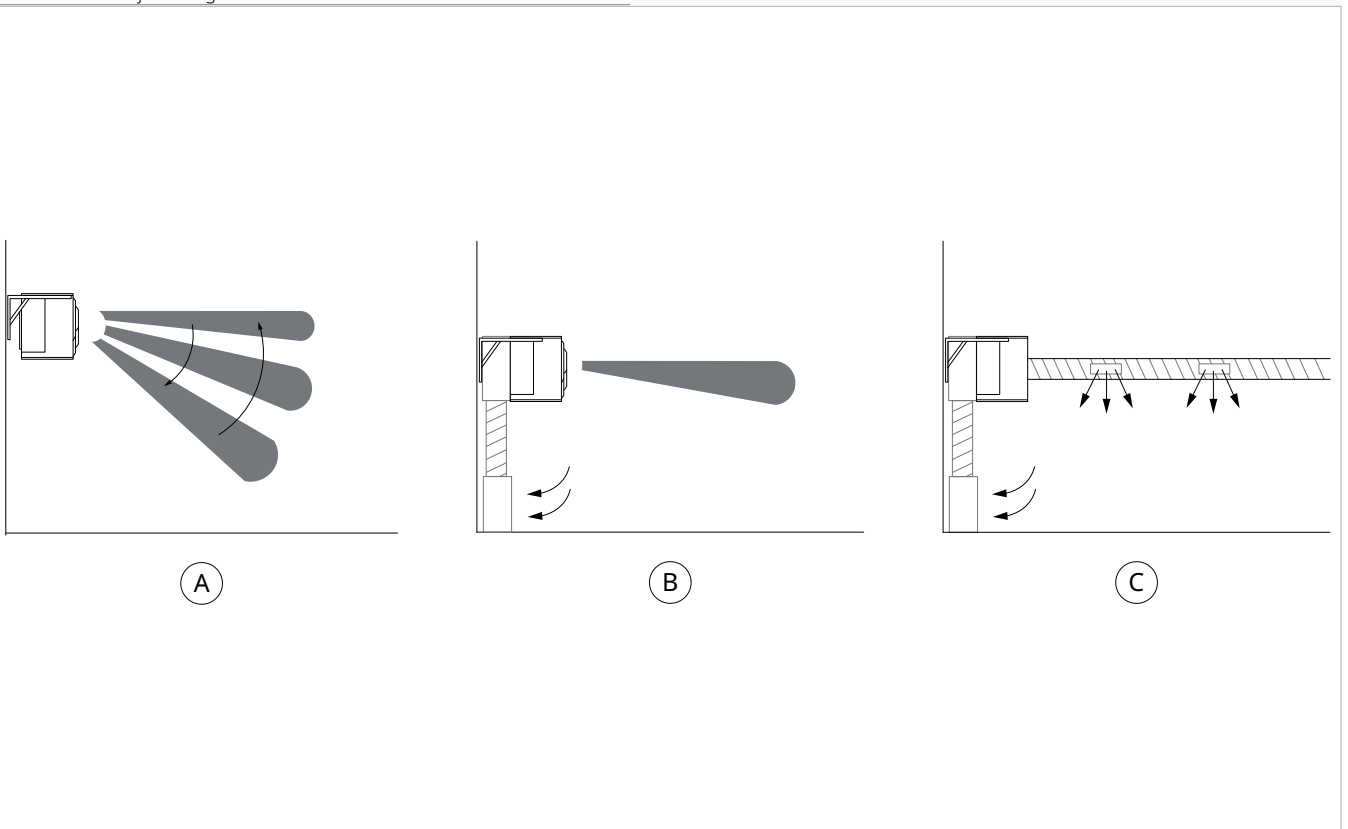

2.7 Compatible accessories

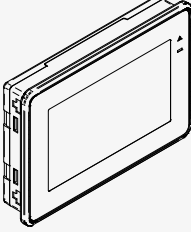
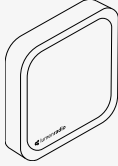
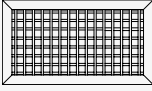
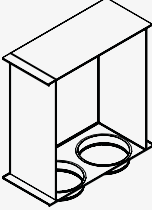
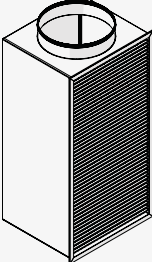
Description	Code
Commands	
	<p>TNF - Electronic touch control</p> <p>AHRX0012</p>
	<p>Wi-Fi module</p> <p>AHRX0013</p>
Duct grille for air supply	
	<p>Duct grille for air supply for duct configurations for sizes 15 and 30</p> <p>AHRX007</p>
Ducted air intake plenum kit	
	<p>Rear air intake module with bottom connection for the displacement module for size 15.</p> <p>AHRX0051</p>
	<p>Rear air intake module with bottom connection for the displacement module for size 30.</p> <p>AHRX0052</p>
Ground air intake module	
	<p>Ground-level air intake module for displacement, supplied complete with grille and filter for size 15.</p> <p>AHRX0061</p>
	<p>Ground-level air intake module for displacement, supplied complete with grille and filter for size 30.</p> <p>AHRX0062</p>

INSTALLATION

3.1 Preliminary Warnings

- ⚠ **For detailed information on the products, refer to chapter 8 p. 47.**
- ⚠ The installation must be carried out by the installer. There is a risk of water leakage, electric shock or fire if the installation is not performed correctly.
- ⚠ During installation, it is necessary to observe the precautions mentioned in this manual, and on the labels affixed to the inside of the appliances, as well as to take every precaution suggested by common sense and the safety regulations in force at the place of installation.
- ⚠ Using only the supplied installation-specific components is recommended. Use of different components could lead to water leakage, electric shock or fire.
- ⚠ Failure to apply the indicated rules may cause malfunctions of the appliances and relieves the manufacturer from any warranty and from any damage caused to persons, animals or property.

Preliminary warnings for R32

- ⚠ Before working on systems containing flammable refrigerants, it is necessary to perform safety checks to ensure that the risk of combustion is minimized.
- ⚠ The appliance must be protected from accidental impacts to prevent mechanical damage.
- ⚠ Do not pierce or burn.

3.2 Reception

Preliminary Warnings

- ⚠ Upon receipt of the package check that it is not damaged, otherwise accept the goods with reserve, producing photographic evidence of any damage.
- ⚠ In the event of damage, notify the shipper by registered mail with return receipt within 3 days of receipt. Presenting photographic documentation, similar information should also be sent by fax to the manufacturer.
- ⚠ No reports of damage will be taken into account later than 3 days after delivery.
- ⚠ The packaging should be transported in a horizontal position without tilting. If it is tilted, please notify the carrier immediately.

Package description

The packaging is made of suitable material and carried out by experienced personnel. The units are all checked and tested and are delivered complete and in perfect condition. The appliance is shipped in standard packaging consisting of a cardboard box and a set of polystyrene foam protectors, placed on a wooden pallet and secured with straps.

3.3 Dimensions and weights with packaging

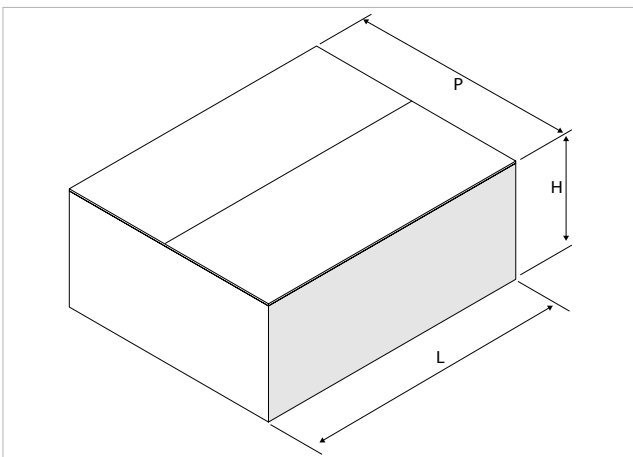

Models	u.m.	OKKI 15 kW	OKKI 30 kW
Packaging dimensions (1)			
Width	mm	1080	1430
Depth	mm	880	1100
Height	mm	1030	1100
Weight	kg	82,7	107,5
1. Excluding pallet			

3.4 Handling with packaging

Preliminary Warnings

- ⚠ The unit may only be handled by qualified personnel adequately equipped and with equipment suitable for the weight and dimensions of the unit.
- ⚠ Before each handling operation, check the lifting capacity of the machinery used in accordance with the indications on the packaging.

Handling

With pallet:

- use a forklift

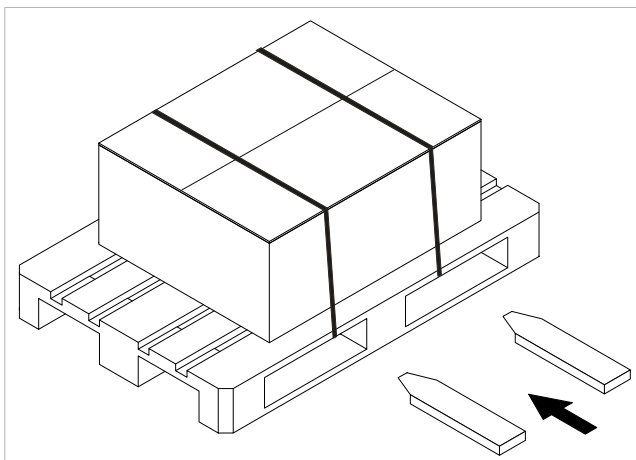

Without pallet:

- use the handles provided on the packaging

- ⚠ The packaging must be transported in a vertical position without being tilted.
- ⚠ When the load is lifted from the ground, stay clear of the immediate and surrounding area.
- ⚠ Check the information on the packaging for the amount of stackable packages.
- ⚠ In manual operations, the maximum weight per person required by current legislation must always be observed.

- ⚠ The unit can only be moved manually for short trips in exceptional cases. In this case it is necessary to carefully check that the weight of the unit does not exceed what is stipulated by the regulations with respect to the number of people employed.

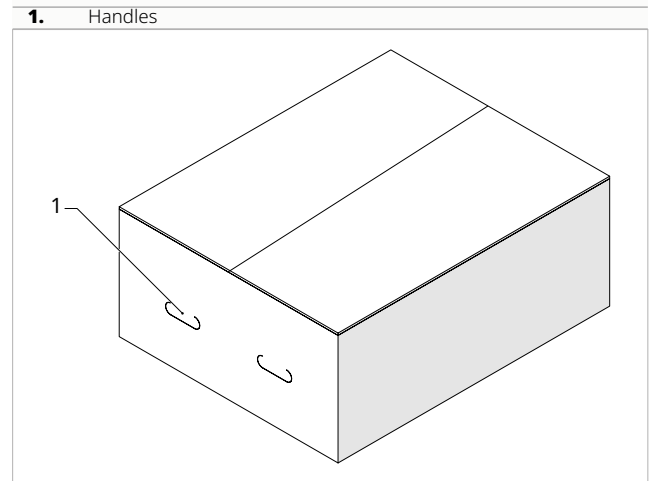

Storage

Preliminary Warnings

- ⚠ Stored in accordance with the applicable national regulations.
- ⚠ Store in a closed environment protected from the weather, off the ground by means of sleepers or pallets

with temperatures not below 0 °C, up to a maximum of 40 °C.

- ⚠ Do not overturn the packaging.
- ⚠ Place the appliance only in a vertical position.

Unpacking

Preliminary Warnings

- ⚠ Check that the individual components are present.
- ⚠ Check that no components were damaged during transport.
- ⚠ Dispose of the packaging components following the applicable waste disposal regulations. Check for disposal arrangements with your municipality.
- ⚠ Handle with care.

- ⚠ The appliance must always be moved in a vertical position.
- ⊖ The packing material (cardboard, staples, plastic bags, etc.) must not be dispersed or abandoned in the surrounding environment and must be kept out of children reach, as it can be dangerous.

Removing the packaging

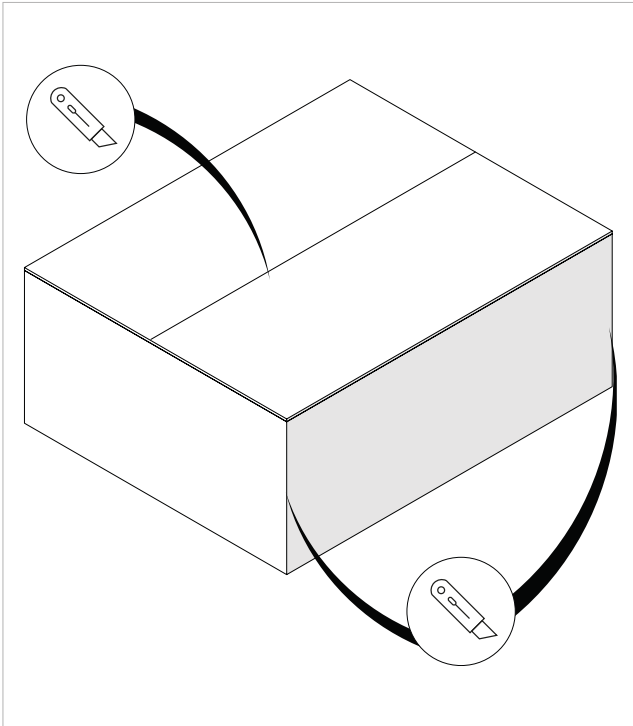

To remove the packaging:

- use a cutter
- open the cardboard packaging
- ⓘ To aid removal of the product, also cut the vertical edges.
- remove the accompanying components
- remove the polystyrene elements
- remove the appliance from the box

Accompanying material

They are included with the appliance, inside the packaging:

- Indoor unit installer manual
- Outdoor unit installer manual
- ⚠ Check the presence of the individual components.

3.6 Handling without packaging

Preliminary Warnings

- ⚠ The appliance must be handled only by qualified personnel, adequately equipped and with equipment suitable for the weight and dimensions of the appliance.
- ⚠ The unit must be handled using non-slip gloves.
- ⚠ Before each handling operation, check the lifting capacity of the machinery used in accordance with the indications on the packaging.
- ⚠ When the load is lifted from the ground, stay clear of the immediate and surrounding area.

- ⚠ Check the information on the packaging for the amount of stackable packages.
- ⚠ In manual operations, the maximum weight per person required by current legislation must always be observed.

Movement methods

- use a fork lift, scaffolding or other suitable lifting system
- ⚠ The unit can only be moved manually for short trips in exceptional cases. In this case it is necessary to carefully check that the weight of the unit does not exceed what is stipulated by the regulations with respect to the number of people employed.

3.7 Installation site

The location of the appliance must be determined by the plant engineer or a competent person and must take into account both purely technical requirements and any national/local legislation in force.

The device is intended to be installed indoors in a vertical position, fixed to the wall.

- ⚠ The installation position must be chosen close to a wall connected to the outside.

Preliminary Warnings

- ⚠ Avoid installing the unit in the vicinity of:
 - obstacles or barriers that cause recirculation of the exhaust air

- narrow places where the sound level of the appliance can be enhanced by reverberations or resonances
- environments with the presence of flammable or explosive gases
- very damp environments (laundries, greenhouses, bathrooms with high humidity, etc.) to prevent the formation of condensation on the external panels of the unit
- environments with the presence of flammable or explosive gases or flammable fluids
- solar radiation and proximity to heat sources
- ⚠ Avoid placing the unit within 1 metre of radio and video equipment.

- ⚠ Do not install above heat sources.
- ⚠ Ensure that:
 - the installation site of the unit must be chosen with the utmost care to guarantee adequate protection from shocks and consequent damage
 - the supporting surface is capable of supporting the weight of the appliance
 - the supporting surface does not affect load-bearing building elements, piping or power lines
 - the functionality of load-bearing elements is not compromised
 - there are no obstacles to the free circulation of air through the holes (plants, leaves...)
 - the appliance must be installed in a position where it can be easily serviced
 - the safety distances between the units and other appliances or structures are scrupulously respected so that the air entering and leaving the fans is free to circulate
- ⚠ If improperly installed or placed on an unsuitable surface, the unit, if detached from its base, may cause damage to persons or property.
- ⚠ The appliance must not be in a position where the air flow is aimed directly at a person.
- ⚠ Provide the following:
 - a drain nearby for the outflow of condensation
 - a compliant power supply nearby

Preliminary warnings for R32

- ⚠ The appliance must be installed in well-ventilated environments that have a minimum floor area as indicated in the table "Minimum Floor Area" based on the total refrigerant charge of the circuit.
- ⚠ **The refrigerant charge refers to the total amount of refrigerant in the circuit, which includes the factory charge and any additional charge.**
- ⚠ Please refer to the technical rating plate on the associated outdoor unit for the quantity of refrigerant loaded into the unit.
- ⚠ If the appliance is placed in a poorly ventilated area, precautions must be taken to prevent the accumulation

of leaked refrigerant, thus avoiding the risk of fire or explosion.

- ⚠ The appliance should be placed in a room where there are no continuously operating open flames (such as a gas appliance in operation) or ignition sources (such as an operating electric heater).
- ⚠ Any ventilation openings must be kept clear of obstacles.
- ⚠ Perform the following checks:
 - Perform safety checks to ensure that the risk of combustion is minimized
 - avoid working in confined spaces
 - delimit the area around the workspace
 - ensure safe working conditions around the area by checking for flammable materials

Minimum floor area

m (kg)	Amin (m ²)
1,8	Without limitations
2,0	2,55
2,1	2,81
2,2	3,09
2,3	3,38
2,4	3,68
2,5	3,99
2,6	4,31
2,8	5,00
3,0	5,74
3,4	7,38
3,8	9,22
4,2	11,26
4,6	13,50
5,0	15,96
5,4	18,61
5,8	21,47

- 2. **M** Refrigerant charge
- 3. **Amin** Minimum floor area

3.8 Minimum installation distances

The clearance zones for the installation and maintenance of the appliance are shown in the figure. Established spaces are necessary to avoid barriers to airflow and allow for normal cleaning and maintenance.

- ⚠ Make sure that there is sufficient space to allow the panels to be removed for routine and supplementary maintenance operations.
- ⚠ Ensure a spacious and open area in front of the unit to guarantee proper airflow.

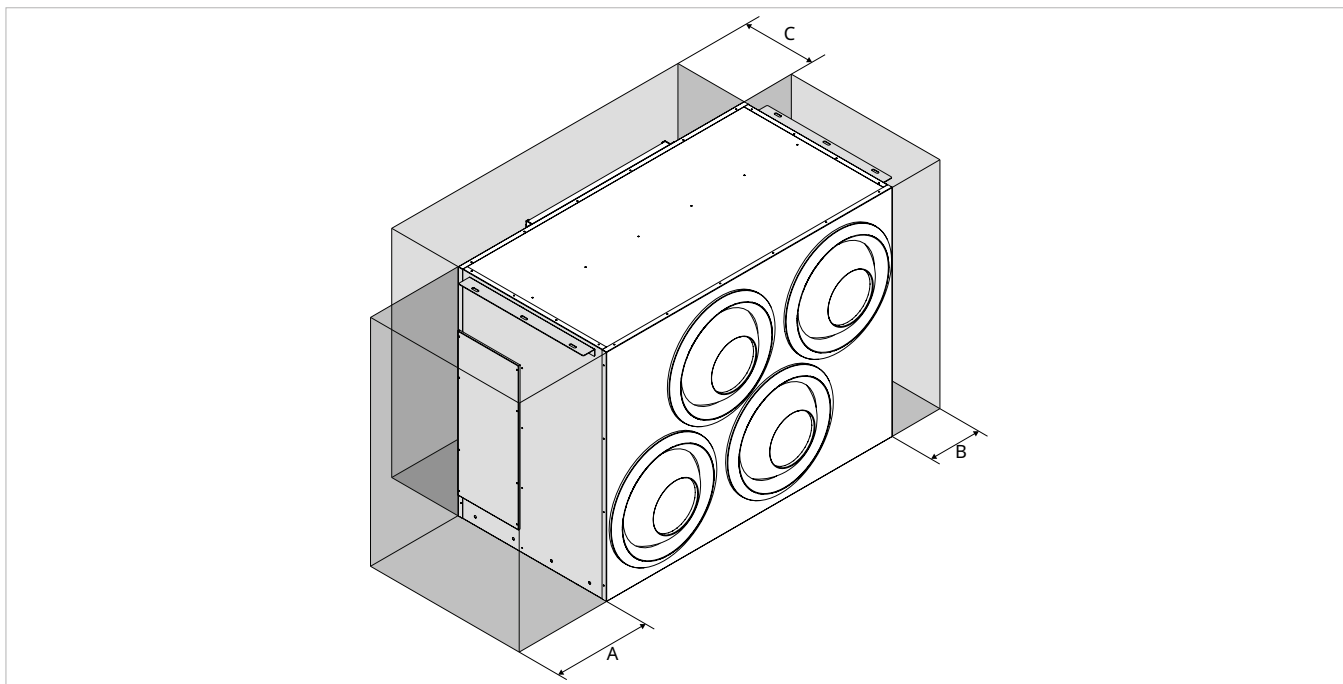

Models	u.m.	OKKI 15 kW	OKKI 30 kW
Minimum distances			
A	mm	500	500
B	mm	200	200
C	mm	300	300

Installation height limits

- A** Minimum installation height
- B** Maximum installation height

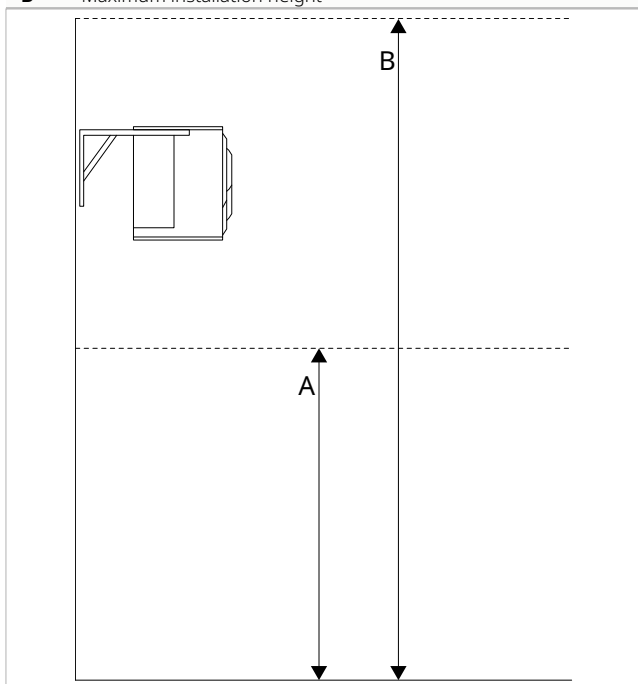

Models	u.m.	OKKI 15 kW	OKKI 30 kW
Installation limits			
A	mm	6000	6000
B	mm	3000	3000

⚠ The established heights are necessary to ensure the proper functioning of the unit.

3.9 Positioning

Preliminary Warnings

⚠ Check that:

- the surface supports the weight of the appliance
- the surface does not affect piping or power lines

- the functionality of load-bearing elements is not compromised

Positioning the unit

The unit can be installed in two different ways:

- Vertical ceiling installation
- Vertical wall installation

Installation brackets

The unit is supplied with installation brackets positioned laterally on the upper part of the unit.

It is possible to modify the position of the brackets on the bottom of the unit.

1. Upper installation bracket (standard)

2. Lower installation bracket

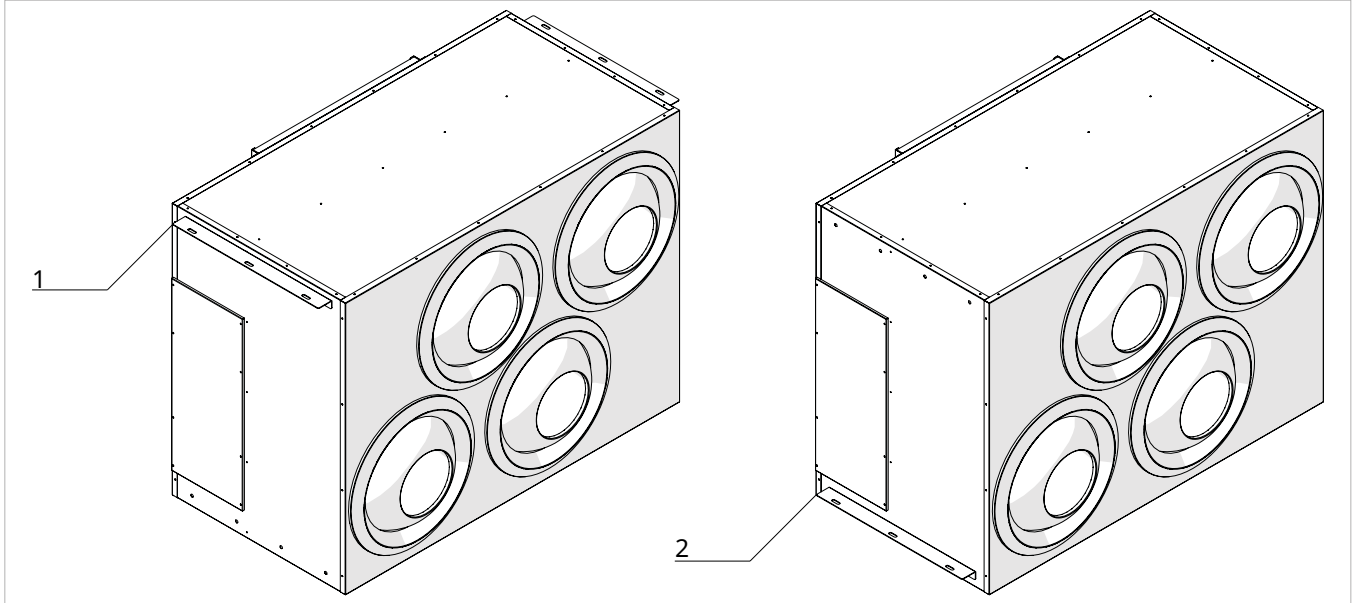

To modify the position of the brackets:

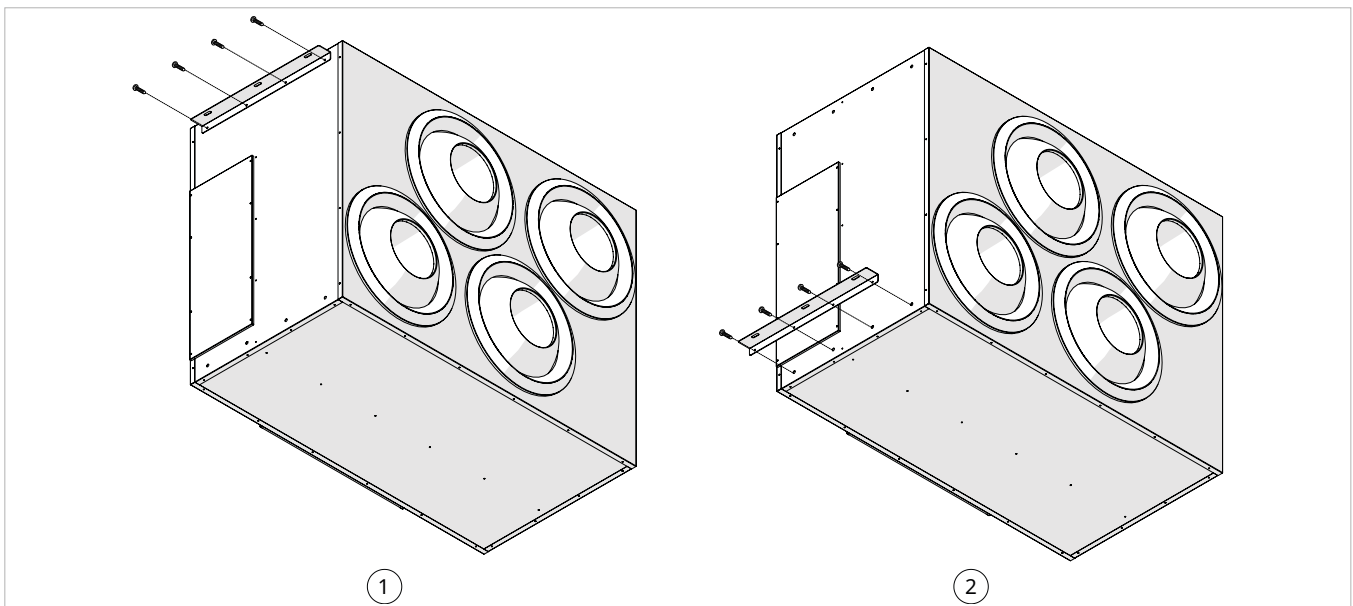

- remove the screws from the installation bracket
- install the bracket on the bottom of the unit using the previously removed screws

Wall installation

⚠ Check the correct orientation of the unit.

- A** Unit installed with the bracket in the upper position
- B** Unit installed with the bracket in the lower position

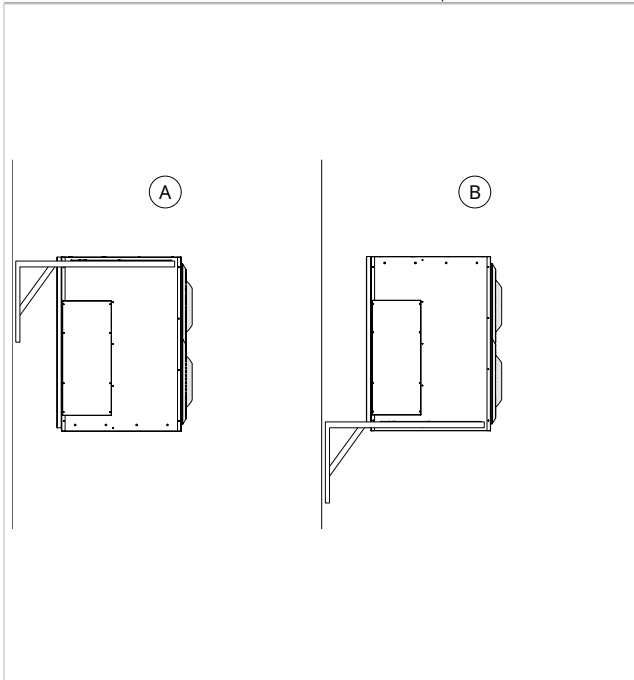

- mark the position of the fixing holes
- use fixing systems appropriate for the type of supporting surface and the weight of the unit
- secure the unit to the fixing system

Check that:

- it is levelled
- the minimum distances and installation height limits are respected

Ceiling installation

⚠ Check the correct orientation of the unit.

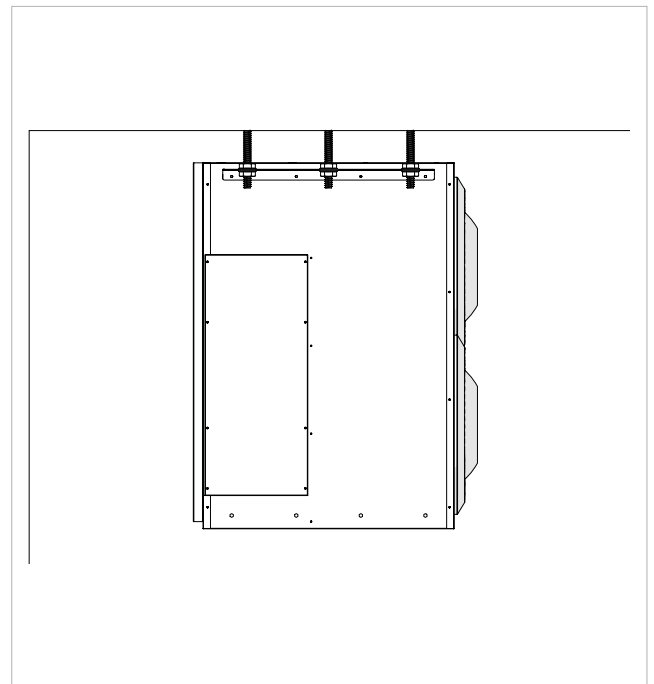

- mark the position of the fixing holes
- use fixing systems appropriate for the type of supporting surface and the weight of the unit
- secure the unit to the fixing system

Check that:

- it is levelled
- the minimum distances and installation height limits are respected

3.10 Refrigeration connections

Preliminary Warnings

⚠ **The installer must comply with Regulation 303/2008/EC, which, in accordance with Directive 842/2006/EC, defines the requirements for companies and personnel concerning the fixed refrigeration, air conditioning, and heat pump equipment containing certain fluorinated greenhouse gases.**

⚠ **For dimensional information, refer to the chapter [Ref].**

- ⚠ Use equipment suitable for the system refrigerant.
- ⚠ Identify the piping route to minimize tubing length and bends, maximizing system efficiency.
- ⚠ The refrigerant lines should be as straight as possible, and any necessary bends must have a radius greater than 40 mm.
- ⚠ Use exclusively copper pipes specifically designed for refrigeration.

⚠ The pipes must be supplied clean and sealed at the ends. It is possible to use pre-insulated copper pipes for refrigeration.

⚠ The pipes must not contain residues of debris, dirt, or water that could damage the components of the unit and compromise the proper functioning of the appliance.

⊖ It's forbidden to use pipes with a diameter different from that indicated in the technical data table.

⊖ Using refrigerant lines that have been previously used is prohibited as the seal at the flare connection cannot be guaranteed.

⊖ Connecting using regular hydraulic pipes is prohibited.

⊖ Welding is prohibited in the presence of refrigerant within the refrigeration circuit. If necessary, the refrigerant must be recovered, and the circuit cleaned using oxygen-free nitrogen.

Specific warnings for R32

- ⚠ The length of the connecting pipes must be minimized.
- ⚠ Connecting pipes must be shielded from physical damage and should not be installed in an unventilated space smaller than the area specified in the Minimum Floor Area table.
- ⚠ The connecting pipes must be installed in a position unlikely to be exposed to corrosive substances, unless they are made from materials inherently corrosion-resistant or adequately protected against corrosion.
- ⚠ Compliance with national regulations for the gas used is mandatory.
- ⚠ Refrigerant connections must be accessible for maintenance purposes.
- ⚠ Work must be undertaken following a controlled procedure to minimize the risk of presence of flammable gases or vapors while the work is being carried out.
- ⊖ Performing hot work (welding, brazing, etc.) is prohibited.
- ⚠ To make refrigerant connections, the following precautions must be taken:

Area checks

- Perform safety checks to ensure that the risk of combustion is minimized
- avoid working in confined spaces
- delimit the area around the workspace
- ensure safe working conditions around the area by checking for flammable materials

Refrigerant fluid presence checks

- the area must be checked with a specific refrigerant fluid detector before and during work, so the technician is aware of potentially flammable atmospheres
- ensure that the leak detection apparatus is suitable for use with flammable refrigerants, meaning it does not produce sparks, is properly sealed, or inherently safe
- ⊖ Using combustion-based refrigerant fluid detectors, such as a halide torch or any other system using an open flame, is prohibited.

Combustion source checks

- people performing work on a refrigeration system involving exposed piping containing or having contained a flammable refrigerant fluid must refrain from using any combustion source that could lead to the risk of fire or explosion
- all potential combustion sources, including smoking a cigarette, must be kept sufficiently far from the work area during operations in which flammable refrigerant fluid could be released into the surrounding space
- check the surrounding area of the equipment to ensure there are no fire hazards or combustion risks
- place signs stating "No Smoking"

Ventilation area checks

- ensure the area is adequately ventilated
- during work, there must be a continuous level of ventilation
- ventilation should safely disperse any released refrigerant fluid and preferably expel it outside into the atmosphere

Leak detection

- ⊖ Using combustion-based refrigerant fluid detectors, such as a halide torch or any other system using an open flame, is prohibited.
- ⚠ For leak detection, follow the following instructions:
 - use electronic detectors to search for flammable refrigerant fluids
 - before usage, ensure the detectors are properly calibrated
 - calibration operations must be carried out in an area free from refrigerant fluid
 - ensure the detector is not a potential ignition source and is suitable for the refrigerant fluid used
 - if a leak is suspected, all open flames must be eliminated
 - in the event of a leak requiring brazing, it is mandatory to recover all refrigerant fluid from the system or isolate it (using shut-off valves) in a part of the system away from the leak

- ⚠ The use of silicone sealant can compromise the effectiveness of certain types of leak detection instruments.

Recharge procedure

- ⚠ For the recharge procedure, ensure that:
 - there is no contamination between different refrigerant fluids
 - the charging equipment's flexible hoses are as short as possible to minimize the amount of refrigerant fluid
 - the cylinders are kept in an upright position
 - ground the refrigeration system before proceeding with the charge
- ⚠ Before proceeding with the charge, ensure that the leak check has been performed.
- ⚠ Check for refrigerant leaks before leaving the site.
- ⚠ Label the system when the charge is complete.
- ⊖ Overloading the refrigeration circuit is prohibited.
- ⊖ It's prohibited to introduce a refrigerant fluid into the system other than the one indicated or to mix different refrigerant fluids.

Connection diagram

- 1. Liquid line
- 2. Gas line

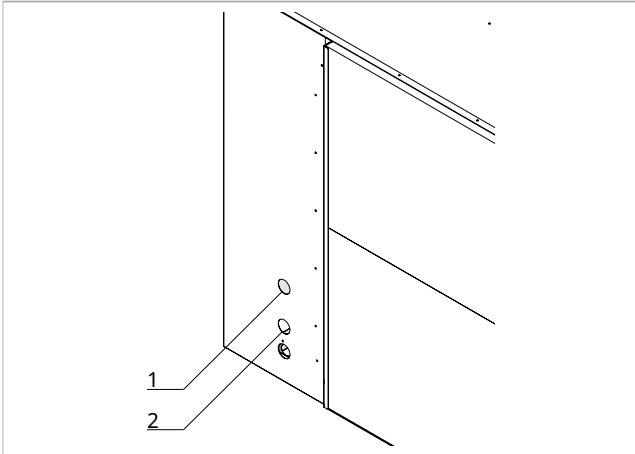

Piping connection

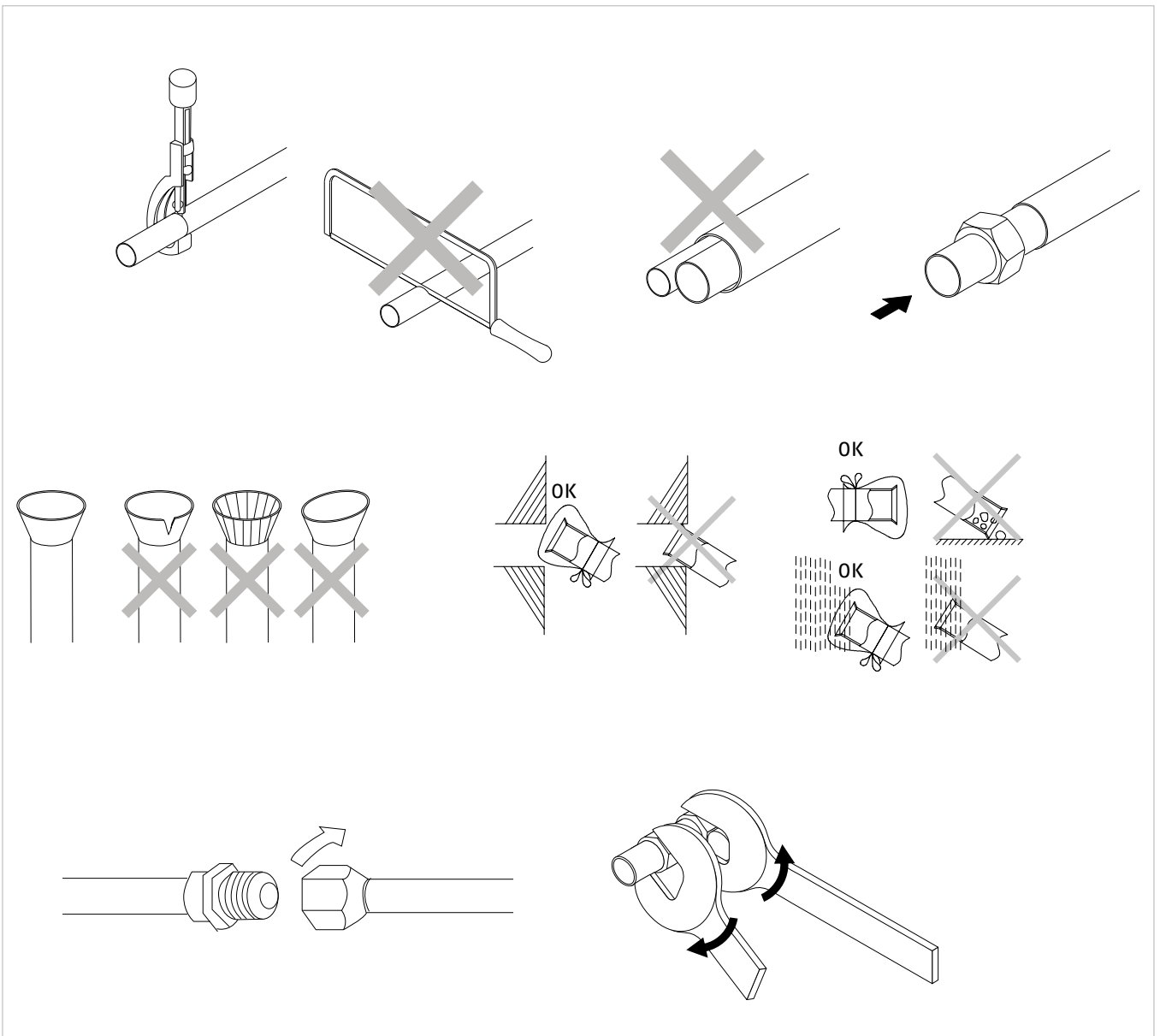

Preliminary Warnings

- ⚠ Mount a cable duct (preferably with internal separators) of suitable dimensions on the wall to later pass the pipes and electrical cables through.
- ⚠ Refrigerant fittings, equipped with shut-off valves, are designed for folder connections.
- ⚠ Cut the pipe sections with an excess of approximately 3-4 cm in length.
- ⚠ Immediately after cutting and deburring, seal the tube ends with insulating tape.
- ⚠ Remove any burrs using the appropriate tool.
- ⚠ Make the cut solely using a tube cutter wheel, tightening at small intervals to avoid crushing the pipe.
- ⚠ **Never use a regular saw to cut the pipes; debris could enter the pipe and later circulate within the system, causing severe damage to the components.**
- ⚠ Avoid the introduction of non-condensable gases (such as air) into the circuit; otherwise, during operation, high pressures might occur, risking ruptures.

Connections

Before connecting:

- insert the fastening nut into the tube
- perform deburring on the tube ends using the appropriate tool

- lubricate the thread of the fitting with refrigerant oil
- ⚠ Do not use any other type of lubricant.
- ⚠ The deburring must not have any breaks, cracks, or splintering.
- ⚠ Avoid using refrigerant oil on the outer part of the flare.

To connect:

- position the refrigerant lines
- hand-tighten the tube nut onto the fitting thread
- use a wrench to hold the threaded part of the fitting steady
- use a torque wrench on the nut to securely tighten it
- ⚠ Keep the leak detector device on near the unit during the connection process to detect any refrigerant leaks promptly.
- ⚠ **For subsequent operations, refer to the manual of the paired outdoor unit.**

Pipe Ø		Tightening torque
mm	inches	Nm
6,35	1/4	18
9,52	3/8	42
12,70	1/2	55
15,88	5/8	60

3.11 Condensate drain connection

This appliance comes with a tray to collect the condensation produced during operation. The condensation must be directed to a suitable discharge point.

Preliminary Warnings

- ⚠ If the drainage line runs into a container (tank or other) it must be ensured that the container itself is hermetically sealed and most importantly it must be ensured that the drainage pipe is not immersed in water.
- ⚠ The hole for the condensate pipe must always have an outwards slope.
- ⚠ The precise position where the tube inlet should be placed concerning the machine is specified on the drilling template.
- ⚠ Pay attention in this case to ensure that the expelled water doesn't cause any damage or inconvenience to objects or people. During the winter period, this water could lead to ice formations outside.
- ⚠ When connecting the condensate drain, take care not to crush the rubber pipe.
- ⚠ If necessary, you can empty the condensate collection tray through a safety drain provided on the unit's base.
- ⚠ If you don't want to set up an external drainage pipe in "cooling-only" mode, it's advisable to plug the condensate drain.

Attachment position

The size and position of the condensate drain attachments are shown below.

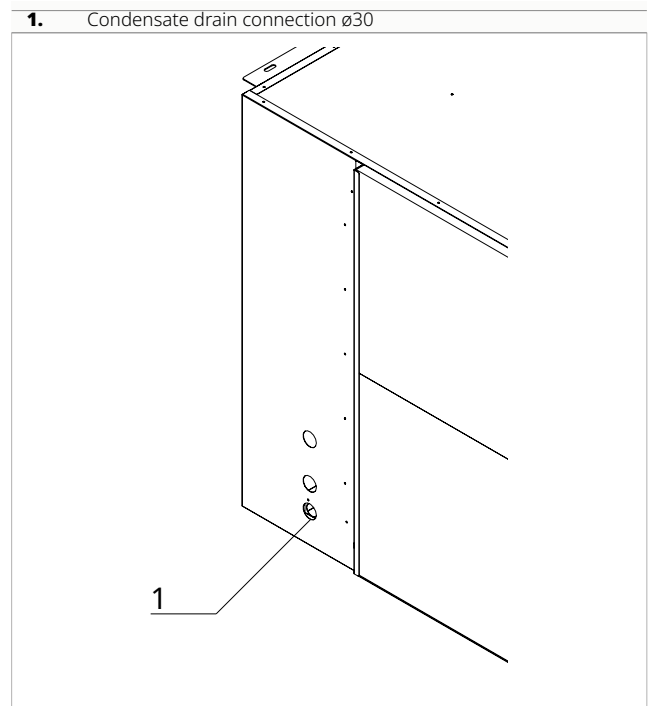

Connections

1. Unit

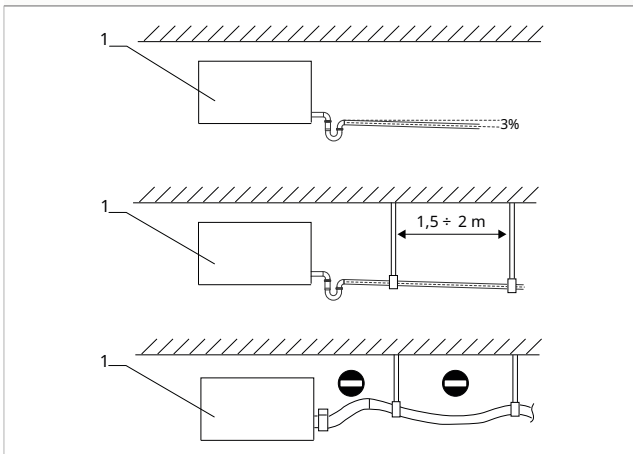

- Connect the drainage pipes to the fitting provided on the unit
- insert a siphon for each pipe near the unit.
- ⚠ If the drainage pipes are connected into a single pipe, install the siphons before the connection point.
- direct the drainage pipes toward a suitable discharge location
- maintain a minimum slope of 3% towards the drain location
- insulate junction points
- ⚠ **It is mandatory to install an adequate siphon on the condensate drainage pipe to prevent the negative pressure generated by the fans from obstructing the proper flow of condensate, which could lead to spillage inside the premises.**
- ⚠ The drainage system must include a suitable siphon to prevent unwanted air from entering the vacuum system. The siphon also prevents the entry of odours or insects.
- ⚠ The siphon must be fitted with a plug at the bottom or must in any case permit quick dismantling for cleaning.
- ⚠ Use plastic drainage pipes.
- ⚠ Avoid metal pipes.
- ⚠ Make sure all joints are sealed to prevent leakage of water.
- ⚠ Condensate drain pipes must be insulated for both indoor and outdoor sections to avoid condensation on the surface and/or frosting problems. The insulation must be inserted all the way to the condensate drain pipe connection on the unit.

3.12 Aeraulic connections

Below are the accessories available for ducting the unit.

1. Duct grille for air supply
2. Ducted configuration
3. Ducted air intake plenum kit
4. Ground air intake module

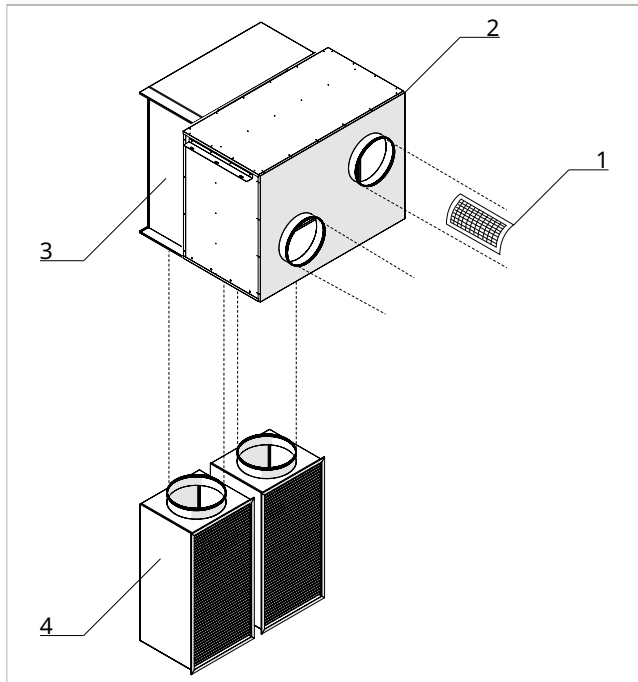

⚠ For the assembly of accessories, refer to the respective instruction sheet.

Preliminary Warnings

- ⚠ The sizing of ducting and supply and extract grids must be carried out by a professionally qualified person.
- ⚠ To prevent the transmission of any vibrations of the machine into the room, an anti-vibration joint should be placed between the fan outlets and the ducts.
- ⚠ The connecting pipes must be of a suitable diameter and supported so that their weight does not put a strain on the appliance.

Connections

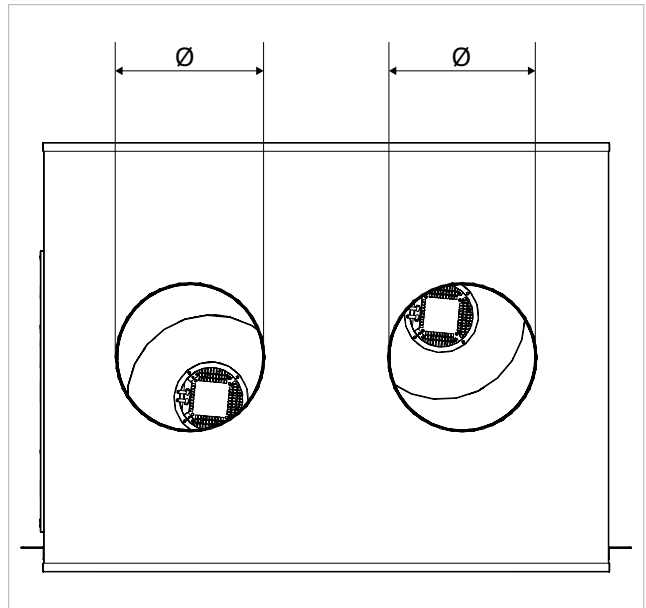

Models	u.m.	OKKI 15 kW	OKKI 30 kW
Connections			
Air connections	mm	355	355

Circular connections

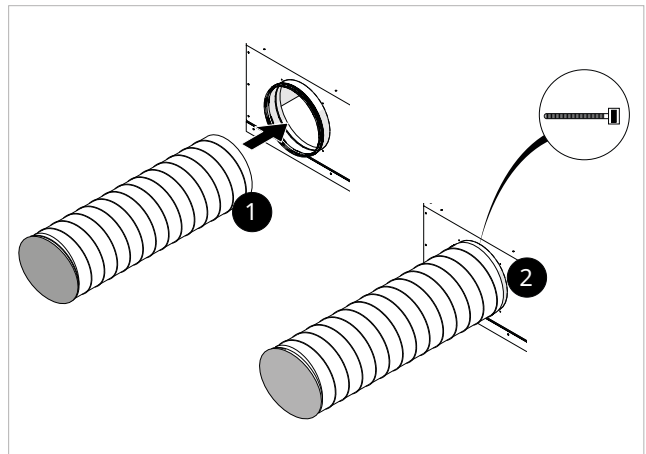

- position the ducts on the connections provided on the appliance
- use a metal clamp or duct fixing collar
- fix the ducts on the attachments

⚠ Use ducts lined with anti-condensation material of a suitable thickness.

3.13 Electrical connections

The appliance leaves the factory completely wired and only requires connection to the power supply, the associated external unit, and any accessories.

Preliminary Warnings

- ⚠ All operations of an electrical nature must be carried out by qualified personnel having the necessary legal requirements, trained and informed about the risks related to such operations.
- ⚠ All connections must be made in accordance with the relevant regulations in force in the country of installation.
- ⚠ Before carrying out any work, make sure that the power supply is switched off.
- ⚠ The unit should only be powered after the plumbing and electrical work has been completed.
- ⚠ References:
 - for electrical connections please refer to the wiring diagrams in this manual, especially for the part concerning the power terminal board
 - for the supply voltage, please refer to the nameplate on the appliance
- ⚠ Check that:
 - the mains characteristics are adequate for the power consumption of the appliance, also taking into account any other machinery in parallel operation
 - the power supply voltage and frequency correspond to those specified on the nameplate on the appliance
 - the cables are suitable for the type of laying in accordance with the IEC standards in force
 - the cable terminals are provided with ferrule terminals, of a cross-section proportionate to the connecting cables, before inserting them into the terminal board
 - the power supply is adequately protected against overloads and/or short circuits
- ⚠ It is mandatory:
 - to connect the appliance to an effective grounding system
 - for units with three-phase power supply, check the correct phase connection
 - install a dedicated disconnecter equipped with delayed fuses or an all-pole magnetothermic circuit breaker complying with IEC-EN standards, suitable for the absorption of the appliance, with differential relay with a maximum setting equal to that specified by the individual electrical regulations
- ⚠ Ensure that a connection to earth is made. Do not ground the appliance to distribution pipes, surge arresters or the ground of the telephone system. If not performed correctly, grounding can cause an electric shock. Momentary high voltage surges caused by lightning or other causes could damage the heat pump.
- ⚠ A ground dispersion breaker is recommended. Failure to install this device could result in an electric shock.

- ⚠ Electrical connections must be carried out in accordance with the instructions in the manual and the standards or practices governing the connection of electrical appliances at national level. Insufficient capacity or incomplete electrical connections could lead to electric shock or fire.
- ⚠ The power supply line must be adequately dimensioned to avoid voltage drops or overheating of cables or other devices placed on the line.
- ⚠ Use a dedicated power supply circuit. Never use a power supply to which another appliance is also connected due to risk of overheating, electric shock or fire.
- ⚠ For the electrical connection, use a cable of sufficient length to cover the entire distance without any connection. Do not use extension cables. Do not apply other loads on the power supply.
- ⚠ After connecting the interconnection and power supply cables, ensure that the cables are arranged so that they do not exert excessive forces on the covers or electrical panels. Install the covers on the cables. Incomplete connections of the covers can lead to overheating of the terminals, electric shock or fire.
- ⚠ Any replacement of the power cable must only be carried out by qualified personnel and in accordance with current national regulations.
- ⚠ The manufacturer is not liable for any damage caused by the lack of earthing or failure to comply with the specifications in the respective diagrams.
- ⚠ The appliance is equipped with a noise filter as required by current regulations. Use selective residual current circuit breakers to compensate for the micro leakage to earth of this device.
- ⊖ Using gas and water pipes to ground the appliance is prohibited.

Preliminary warnings for R32

- ⚠ The R32 refrigerant gas is slightly flammable and odorless.
- ⚠ All precautions regarding the handling of refrigerant must be followed in accordance with current regulations.
- ⚠ Avoid proximity to continuously operating ignition sources (open flames, gas appliances, electric stoves, lit cigarettes, etc.).
- ⊖ Smoking is prohibited near the appliance.
- ⊖ The use of mobile phones is prohibited near the appliance.
- ⚠ Perform the following checks:
 - Perform safety checks to ensure that the risk of combustion is minimized
 - avoid working in confined spaces
 - delimit the area around the workspace
 - ensure safe working conditions around the area by checking for flammable materials

Power line dimensioning

Use the tables below for the sizing of the power supply line and its protection device.

These are not average draw or transient peaks, but values to be considered for the correct sizing of the plant and the request of the contractual power (excluding loads due to the normal operation of the building).

- ⚠ Maximum power is reached only in exceptional cases. Therefore, the indicated trip current is suggested to guarantee a balance between machine absorption and incidence in the general system.
- ⚠ The indicated minimum cable cross-section area must be verified according to the actual conditions of the installation: length of the cable, characteristics of the electrical supply, etc.
- ⚠ For units equipped with electrical heating elements, the draw values of the units must be added to those of the heating elements shown in the following tables.

Access to the electrical panel

- ⚠ Access to the electrical panel is only permitted to qualified personnel.
- ⚠ Before carrying out any work, ensure that the power supply is switched off.

- remove the panel

1. Connection cable entry

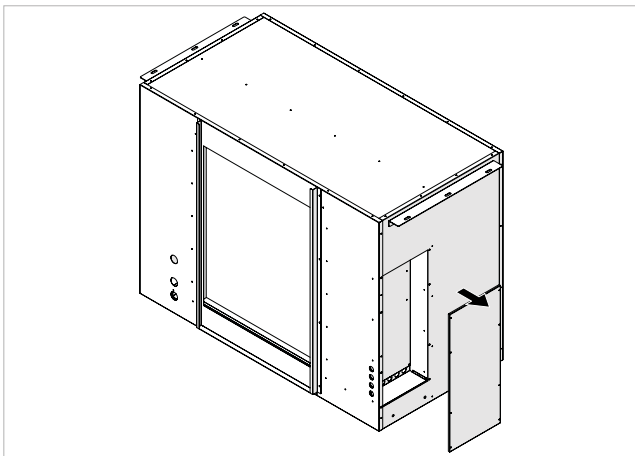
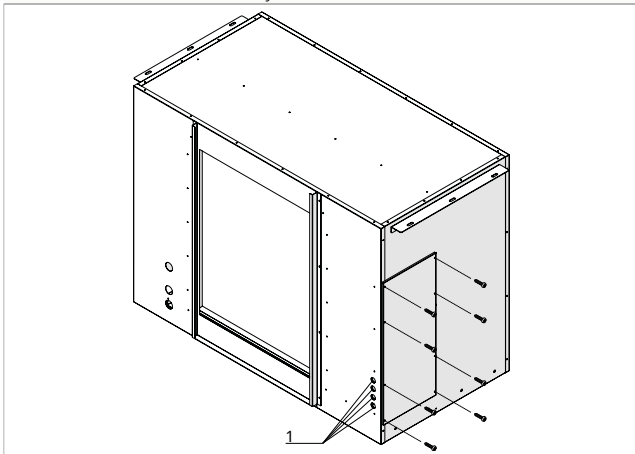

To access the connections:

- undo the fixing screws on the panel of the electrical panel

Connections

Before connecting the unit to the mains power supply, make sure that the disconnecter is open. The power supply of the unit (single phase or three phase) must be connected to the appropriate terminals, subjected to the action of the isolating switch.

- ⚠ Use properly sized cables to avoid voltage drops or overheating.
- ⚠ Before making the connection to the terminals, carefully read the information provided in this manual.

Connection diagram

Single connection diagram

1.	230/1/50 power supply	6.	Control panel communication cable
2.	Disconnecter	7.	External unit communication cable
3.	Power cable	8.	Outdoor unit
4.	Unit	9.	Power supply 230/1/50 and 400/3/50 according to the model.
5.	Remote control		

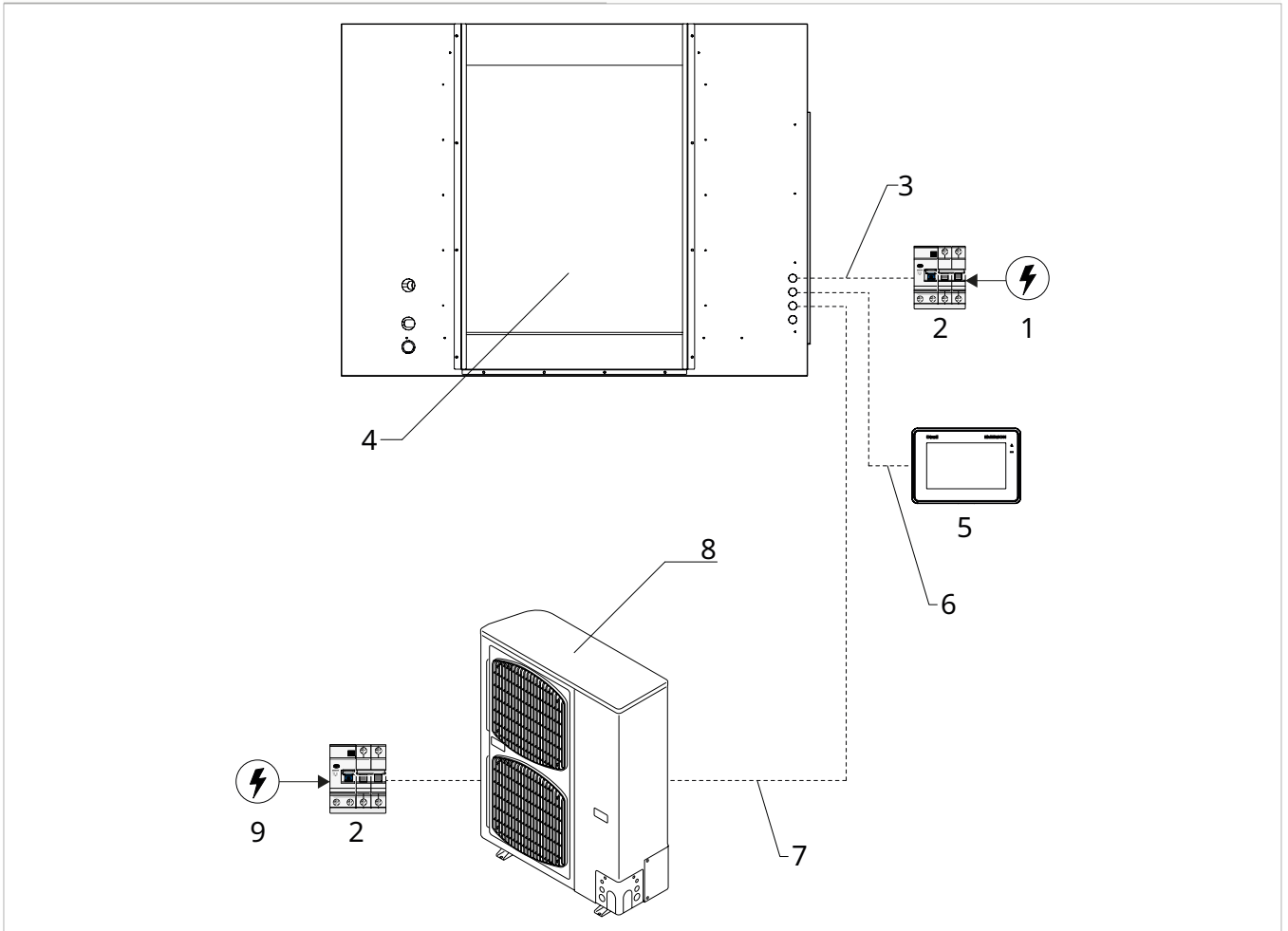

On-board electrical panel

Connection terminal board

- A** X2 Terminal block
- B** External unit connection
- C** Input connection

- D** Output connection
- E** Connection of the control panel
- SE** Main switch (not provided)

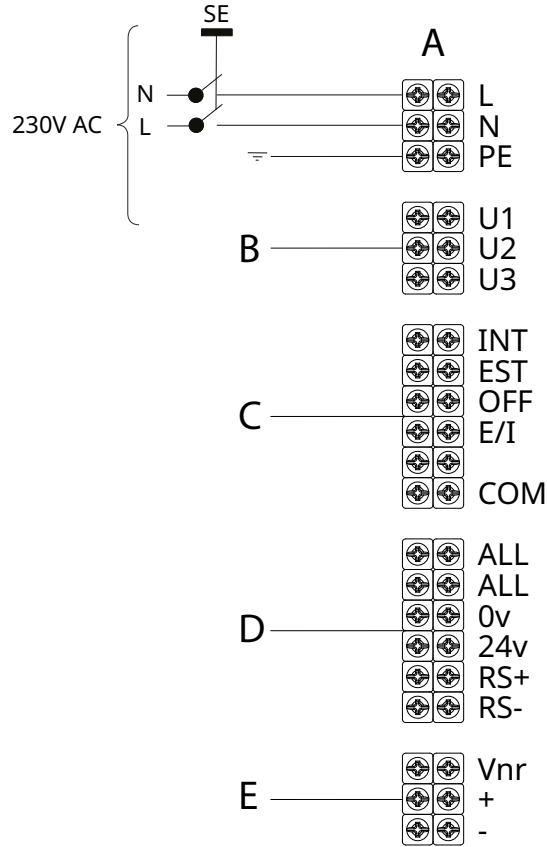

External unit connection

The control of the external unit occurs through 3 wires with a voltage of 230V for the 15kW unit:

- U1
- U2
- U3

It occurs with two low-voltage wires for the 30kW unit:

- U1
- U2

15 kW version

1. External unit communication

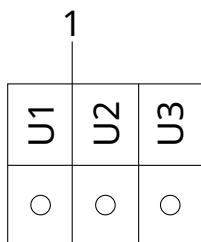

30 kW version

1. External unit communication

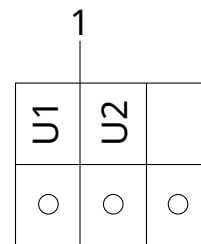

Input connection

Temperature request connection

It is possible to connect a thermostat to the unit that includes forcing the unit into integration mode. A contact is provided through a standard thermostat with a clean output contact.

Contact closed: unit in integration.

⚠ The contact will take priority over the NTC probe.

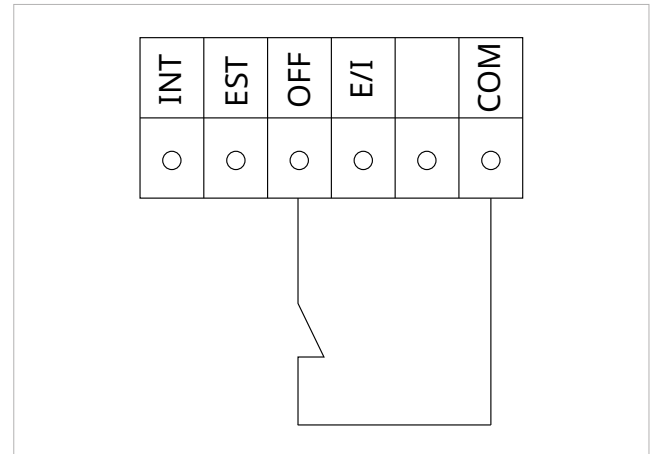
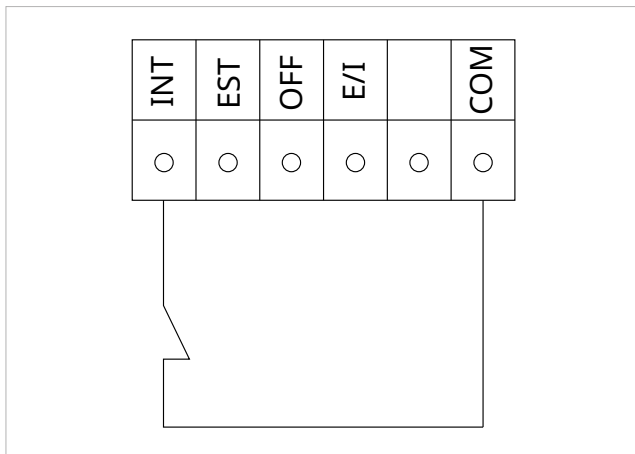

Summer/Winter connection

The unit can be connected via a clean contact to a device for selecting the operating season.

With a closed contact, the unit will be in summer mode, and with an open contact, the unit will be remotely forced into winter mode.

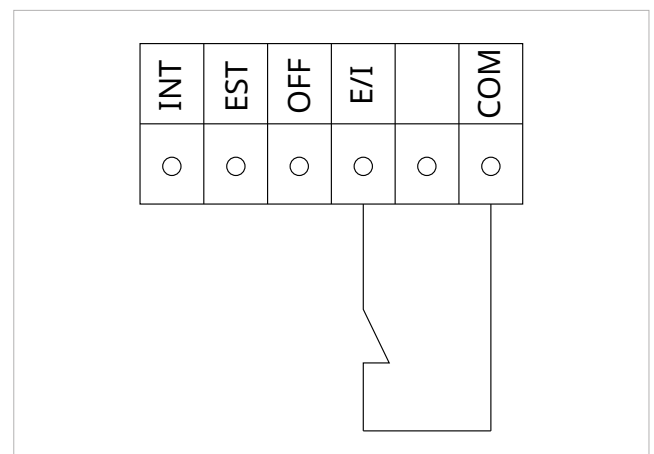

External alarm connection

The unit can signal an external alarm, such as the generator alarm or a pump alarm serving the unit, providing the user with early information about the malfunction.

Closed contact: External alarm signaling activated.

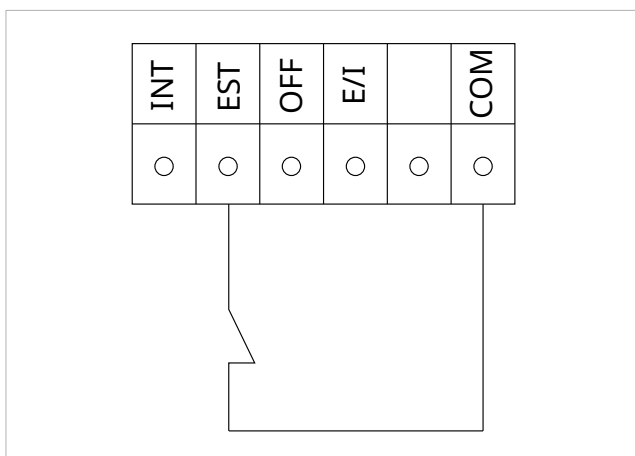

Output connection

Generic alarm signaling connection

The unit can signal a machine alarm through the generic alarm contact; the contact is a clean contact.

Closed contact: Alarm signaling activated.

Remote power on/off unit connection

The unit can be connected via a clean contact to a device for remote power on/off, such as a switch or a timer.

With a closed contact, the unit will be ON, and with an open contact, the unit will be remotely forced OFF.

1. Alarm notification

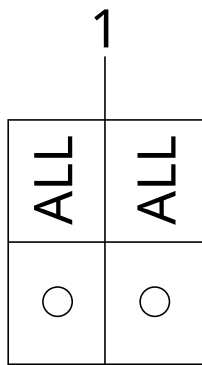

Multiple connection

The unit is designed to connect multiple devices under the same command.

⚠ One controller can control a maximum of 8 devices. Two types of multiple connections are provided:

- Wired RS485 connection
- Wi-Fi connection

Multiple wired connection

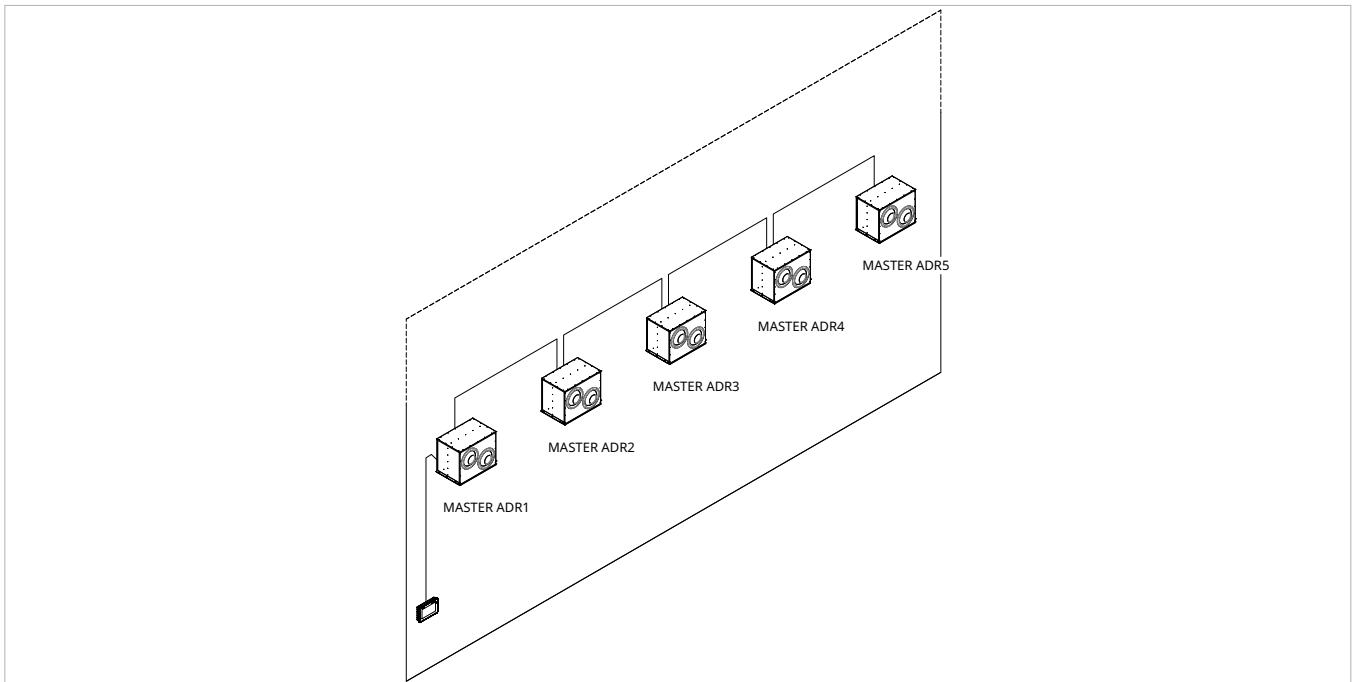

The network is a Modbus RS485 RTU

- RS (-) RS485 Network
- RS (+) RS485 Network

Multiple Wi-Fi connection

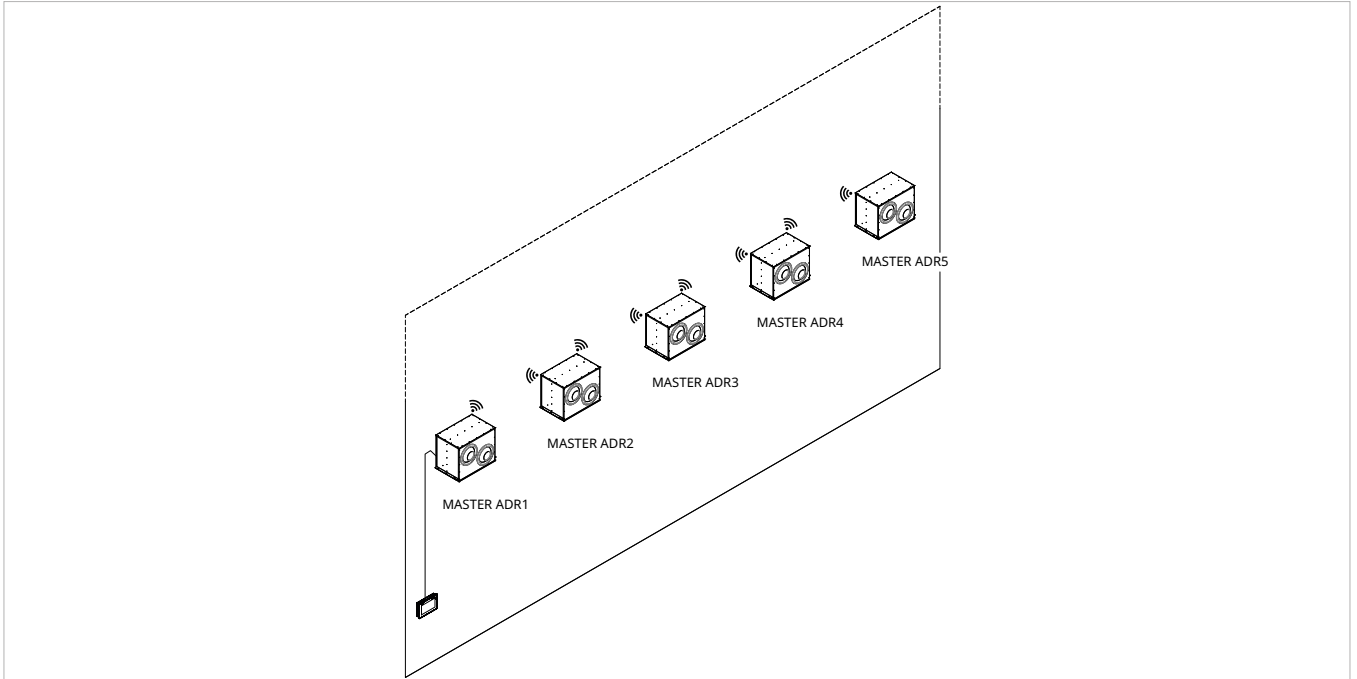

For Wi-Fi connection, it's necessary to install a Wi-Fi module to manage multiple connections. The module is installed outside the unit and wired through the terminal block.

1. 24V AC power supply
2. Modbus RTU

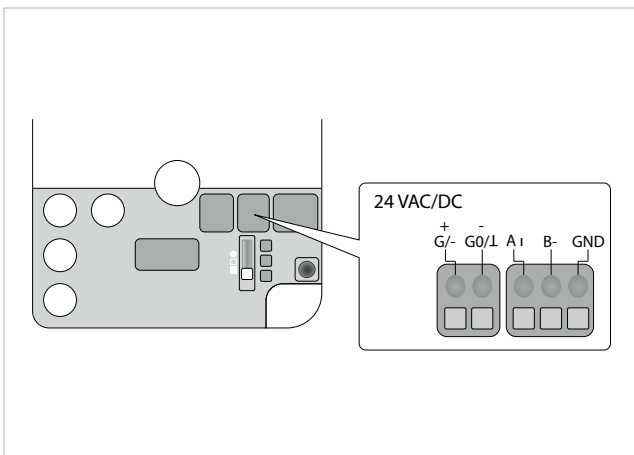
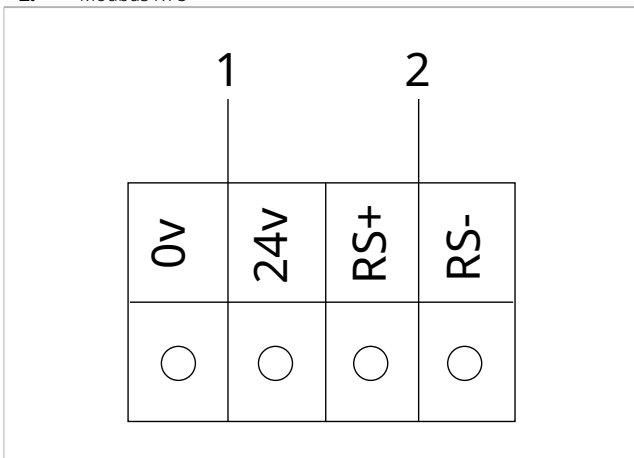

REMOTE CONTROL

4.1 Installation

Description

The control panel is a touch screen keyboard that allows control of all the main functions of the device and displays any alarms, with the option of wall-mount or flush-mount installation using the dedicated accessory.

- 1. Mounting hole
- 2. Electrical cable entry hole

- ⚠ The controller can control a maximum of 8 devices.
- ⚠ For operation on the control panel, refer to the manual dedicated to the control panel.

Mounting

- 3. Connection terminal board

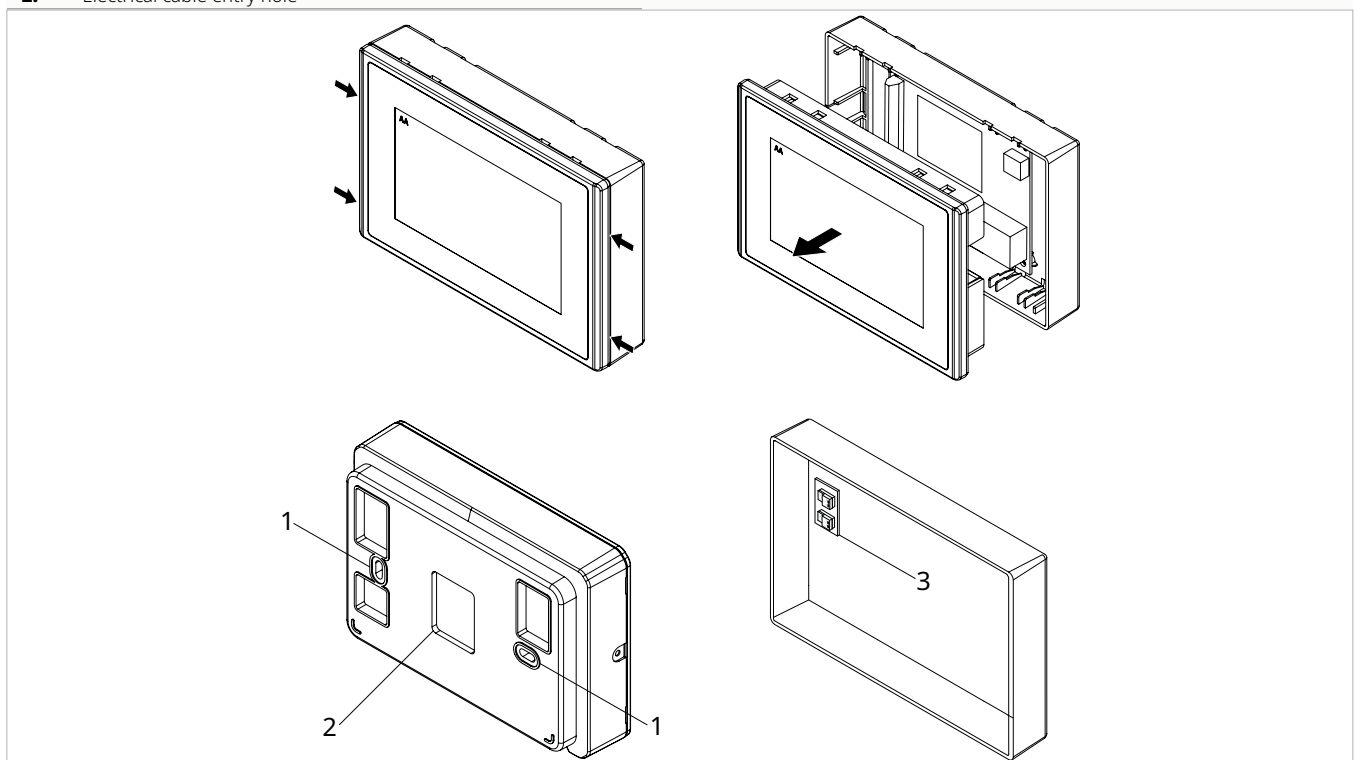

Before mounting on the wall:

- separate the base from the control panel
- use the base as a template to mark out the fixing points

For wall mounting of the control panel:

- drill holes in the wall
- pass the electrical cables through the prepared hole
- fix the base of the control unit to the wall using suitable screws and dowels
- make electrical connections
- close the control panel

- ⚠ Take care not to crush the wires when closing the control panel.

4.2 Electrical connections

Terminal board position

A terminal board

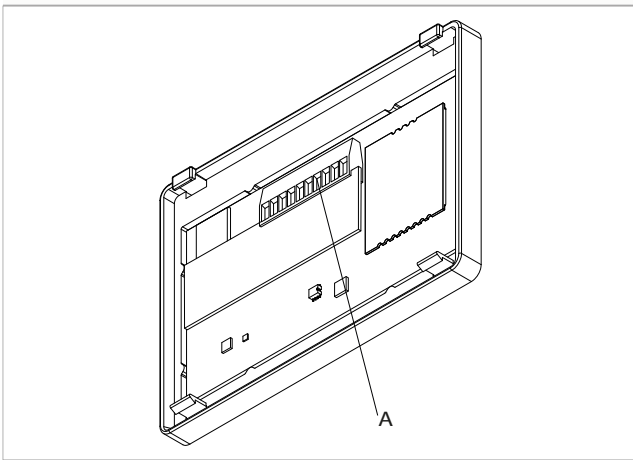

The terminals allow the connection of rigid or flexible cables with cross-sections of 0.2 to 1 mm². For cables equipped with a cable lug with plastic collar the maximum cross-section is reduced to 0.75 mm².

Connection diagram

Connect the control panel to the terminal block provided on the unit.

1. Remote panel

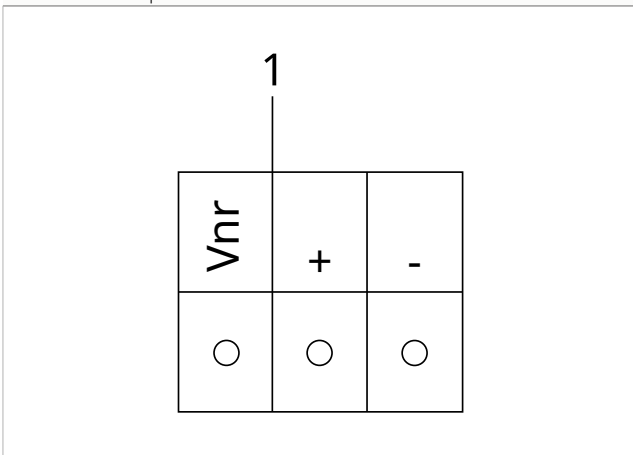

4.3 Interface

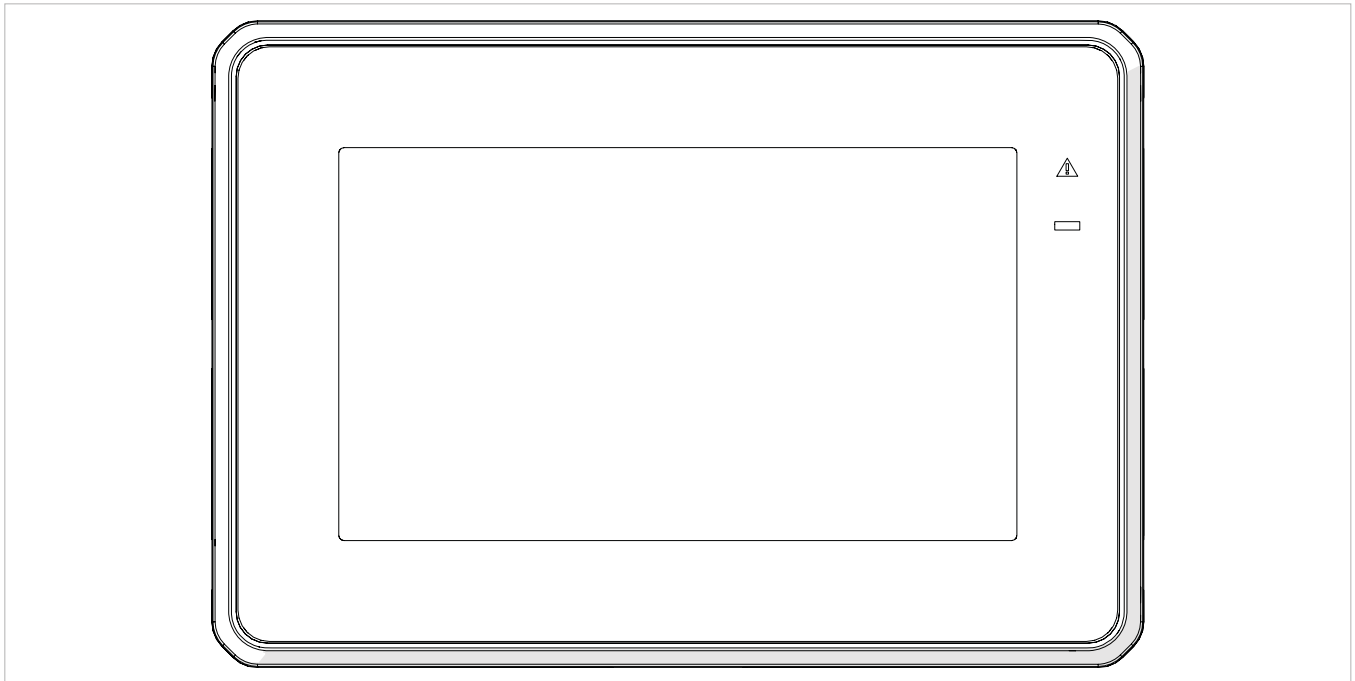

4.3.1 Description

The electronic control panel with a touch interface for wall installation allows:

- adjustment of the room temperature
- management of the main functions of the device
- temperature measurement
- adjustment of the fan speed

Features:

- display of the return air temperature
- internal memory with data storage even in the event of abnormal shutdown or power failure

the multi-unit configuration allows linking multiple units under a single command, offering two connection options:

- modbus, cable connection via Modbus for each individual unit
- Wi-Fi, module for radio communication between units (optional)

⚠ After 300 seconds from the last action, the brightness of the control panel reduces. Pressing any key restores the maximum brightness.

START-UP

5.1 Preliminary Warnings

⚠ **This section is dedicated to the Technical Service Centre. The specifications of the Technical Service Centre are described in chapter [p. 5](#).**

⚠ **Initial commissioning must be carried out by the Technical Service Centre.**

⚠ **For detailed information on accessories, please refer to the relevant instruction sheets.**

See chapter 2.7 [p. 12](#)

⚠ The customer must be present when the appliance is tested and informed of the contents of the manual and procedures. After commissioning, the manual and the warranty certificate must be handed over to the customer.

⚠ Before start-up, all works (electrical, hydraulic and air-flow connections) must have been completed.

5.1.1 Preliminary warnings for R32

⚠ The unit uses environmentally-friendly R32 refrigerant, with a Global Warming Potential (GWP) of 675. Do not release R32 gas into the atmosphere.

⚠ The R32 refrigerant gas is slightly flammable and odorless.

⚠ All precautions regarding the handling of refrigerant must be followed in accordance with current regulations.

⚠ Avoid proximity to continuously operating ignition sources (open flames, gas appliances, electric stoves, lit cigarettes, etc.).

⊖ It is prohibited to use means to speed up the defrosting process or for cleaning other than those recommended.

⊖ Smoking is prohibited near the appliance.

⊖ The use of mobile phones is prohibited near the appliance.

⊖ It is forbidden to introduce objects and substances through the openings provided for the intake and delivery of air.

⚠ Perform the following checks:

- Perform safety checks to ensure that the risk of combustion is minimized
- avoid working in confined spaces
- delimit the area around the workspace
- ensure safe working conditions around the area by checking for flammable materials

Leak detection

⊖ Using combustion-based refrigerant fluid detectors, such as a halide torch or any other system using an open flame, is prohibited.

⚠ For leak detection, follow the following instructions:

- use electronic detectors to search for flammable refrigerant fluids
- before usage, ensure the detectors are properly calibrated
- calibration operations must be carried out in an area free from refrigerant fluid
- ensure the detector is not a potential ignition source and is suitable for the refrigerant fluid used
- if a leak is suspected, all open flames must be eliminated
- in the event of a leak requiring brazing, it is mandatory to recover all refrigerant fluid from the system or isolate it (using shut-off valves) in a part of the system away from the leak

⚠ The use of silicone sealant can compromise the effectiveness of certain types of leak detection instruments.

5.2 First start-up

Preliminary Checks

Before commissioning, check that:

Operational checks

- all safety conditions have been met
- the unit has been properly secured to the supporting surface or wall
- the minimum technical spaces have been observed

Hydraulics

- the hydraulic connections have been made according to the instructions in the manual
- the hydraulic system has been pressurized and purged
- ensure that the shut-off valves of the hydraulic circuit are open
- the mesh filter is installed and clean
- ⊖ It's forbidden to operate the unit without the water filter installed and clean.

Electrical checks

- the cross-section of the power supply cables is adequate for the absorption of the appliance and the length of the connection made
- grounding is correctly performed
- the electrical connections have been established correctly
- all electrical connections are properly secured and all terminals are adequately tightened
- the voltage is within a tolerance of 10% compared to the unit's nominal voltage
- the power supply for the three-phase models has a maximum phase imbalance of 3%
- all control wires are connected and that all electrical connections are secure

- the supply voltage value is within the set limits and does not fall below the nominal value -10 % during operation

Refrigerators

- the refrigerator connections have been made following the instructions provided in the manual
- the shut-off valves of the refrigeration circuit are open

5.2.1 Powering up

⚠ Before starting, power up the unit for at least 12 hours.

⚠ Make sure that the control panel is switched off.

To power up the unit:

- set the main switch to ON

The display will light up a few seconds after powering up. Check that the operating status is OFF.

⚠ For performing operations, refer to the Control Panel Manual.

Start-up

After all checks have been carried out, the unit can be put into operation.

To activate the appliance:

- please refer to the user manual

Checks with the machineswitched on

After starting up, check that

Operational checks:

- verify the different modes of operation
- verify that the appliance stops and then restarts
- switch the appliance off and on again and check that it restarts correctly
- the appliance operates within the recommended operating conditions (see technical specifications table)
- check that the air flow rates are correct

Hydraulic Checks

- check for proper condensate drainage

Electrical Checks

- the current absorbed is less than the maximum indicated in the technical data table

5.3 Plant delivery

Once all the checks and controls on the correct operation of the plant have been completed, the installer must explain the following to the user:

- the basic functional characteristics of the appliance
- the instructions for use
- the routine maintenance

5.4 Switching off for extended periods

If the appliance is not used for a long period of time, the following steps must be taken:

- deactivating the device
- disconnect the power supply

⚠ To restart the appliance after it has been out of use for a long period, call in the Technical Service Centre.

5.5 External unit control panel

Position

1. External unit control panel

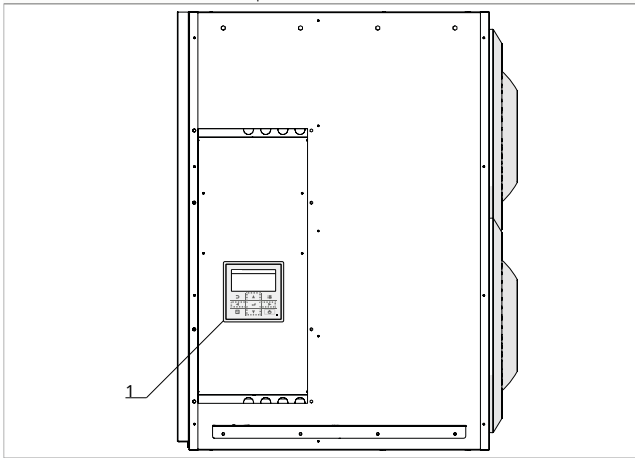

Remote control

- ⚠ The external unit control panel is not a remote control.
- ⚠ The control panel of the external unit is solely used during the initial commissioning to perform the automatic address setting and the initial startup. After that, do not press any other button, do not turn off, or attempt programming.

1. Enter button
2. Power button
3. Operation LED indicator (illuminates during operation/flashes during an alarm)
4. Back button
5. Selection button

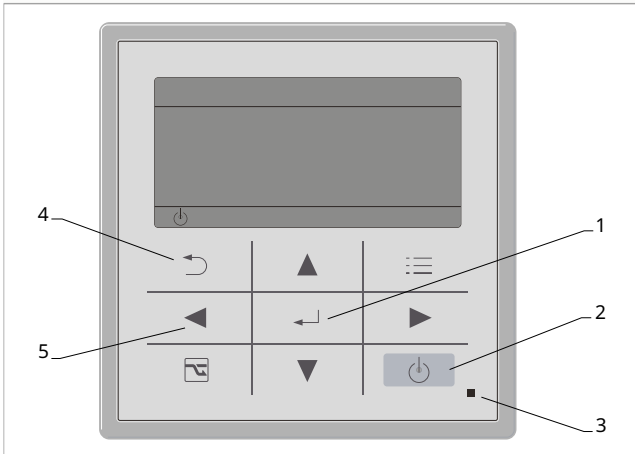

First start-up

- place the main switch of the system on "access"
- rotate the isolator Q1 of the device located in the electrical panel to the I-ON position
- verify that the touchscreen interface is turned off
- check that the emergency interface display shows OFF; if not, press the Standby icon

Within a couple of minutes, the "ASSIGNING" message will start flashing on the external unit's control panel.

This indication will disappear within 4-5 minutes once the panel has successfully communicated with the external unit.

- ⚠ In versions 12-15-18 three-phase, if alarm P05 appears on the control panel of the external unit, the two phases of the power supply must be inverted.

Automatic address setting

Before starting the Assigning procedure:

- verify that the electrical connections between the outdoor unit and indoor unit at terminal block J6 have been correctly made.

A Stand-by screen

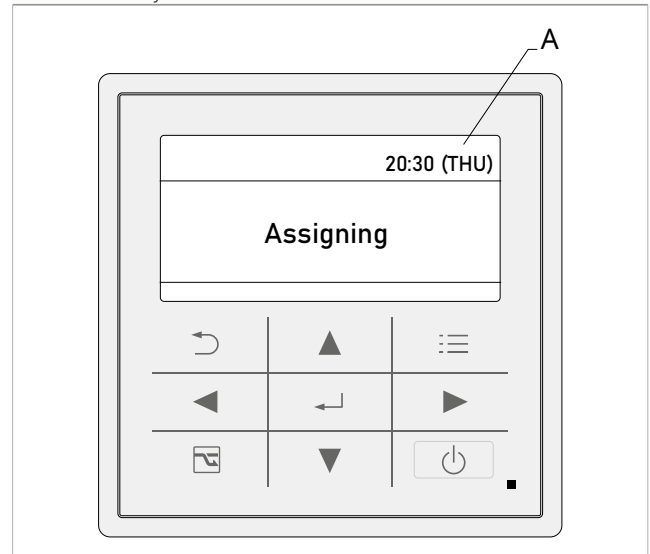

To start the Assigning procedure:

- power up the device electrically
- On the display, "Assigning" appears
- The Assigning procedure starts
- wait a few minutes

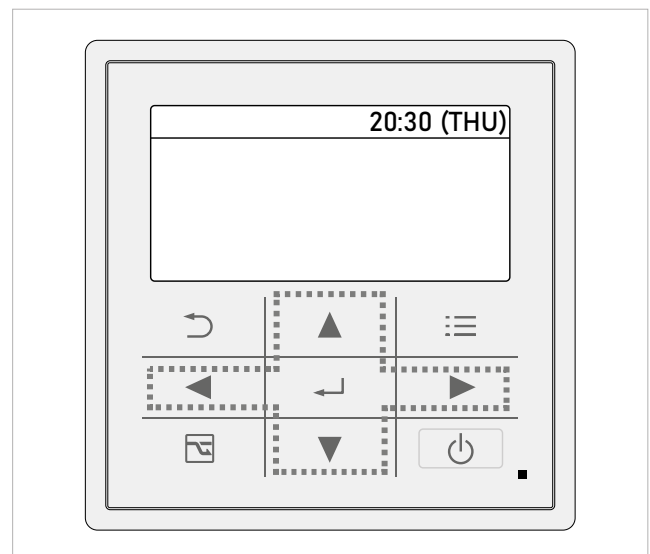

*Assigning disappears from the display
The Assigning procedure has completed*

- wait a minute
- proceed with turning on using the control panel of the indoor unit

⚠ If the Assigning procedure doesn't restart automatically or the symbol ⚠ along with R.C.1 remains displayed, contact the Technical Assistance Center.

⚠ If the ⚠ symbol accompanied by R.C.1 is displayed during the Assigning procedure, remove power from the device.

Meaning of the light indicators on the electronic board of the external unit

Meaning	LED 1	LED 1
absence of communication with the internal unit	○	○
communication established with the internal unit	●	○
normal communication OK (power and validating quantity)	●	●
automatic address setting in progress	☀	☀

- switched on
- switched off
- ☀ alternative flashing

Initial start-up of the external unit control panel

- press Ⓟ

A Display on

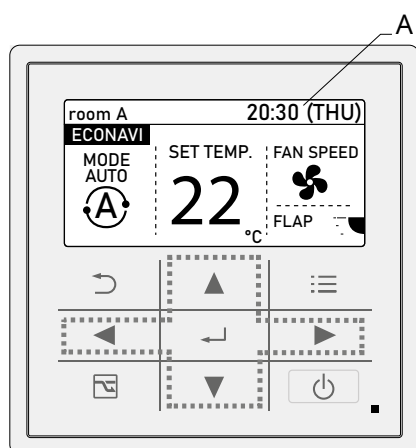

- press ◀
- Select MODE
- press ↵
- press ⬆
- select the auto mode
- press ↵
- wait a few seconds
- ☀ appears on the display.
- wait a few seconds
- remove and restore power to the device
- verify that the settings have been stored

Checks during and after the initial commissioning

After starting up, check that

- the absorbed current of the device is lower than the maximum indicated in the manual of the internal unit
- ⚠ During compressor operation, the electrical voltage should not drop below the nominal value of -10%.
- the appliance operates within the recommended operating conditions
- the hydraulic circuit is completely de-aerated
- the hydrometer pressure is between 1 and 2 bars
- the air-to-water heat pump performs a shutdown and subsequent restart
- the temperature difference between supply and return in the system is between $4 \div 7$ °C.
- ⚠ If the temperature difference is below 4 °C, set a lower circulation pump speed.
- ⚠ If the temperature difference exceeds 7 °C, check the opening of all valves in the system and consider adding an external pump to increase water flow.
- switch the appliance off and on again and check that it restarts correctly

MAINTENANCE

Routine maintenance

Preliminary Warnings

Before any cleaning or maintenance intervention:

- Disconnect the device from the electrical network by setting the main switch of the system to "OFF"
- wait for the components to cool down to avoid the risk of burns
- ⊖ Any technical or cleaning intervention is prohibited before disconnecting the unit from the power supply.
- ⚠ Check for the absence of voltage before performing any operation.
- ⚠ After performing the necessary maintenance operations, restore the original conditions.
- ⚠ It is forbidden to introduce objects and substances through the openings provided for the intake and delivery of air.

Annual operations

The once-a-year maintenance plan includes the following operations and checks and must be carried out by the Technical Service Centre or by qualified personnel.

Electrical circuit

Check:

- electrical supply voltage
- the electrical absorption
- connections tightening
- that there is no damage or excessive wear to electrical cables
- that the gaskets and sealing materials have not deteriorated to such an extent that they are no longer suitable for the purpose of preventing the development of flammable atmospheres inside
- the correct fixing of cable glands
- safety devices

Mechanical checks

Check:

- tightening of the screws, fans and electrical box, of the unit's external panelling
- the state of the structure
- ⚠ Bad fixings result in abnormal noise and vibration.
- ⚠ If oxidised parts are present, treat them with suitable paints to eliminate or reduce oxidation.

Hydraulic controls

Check:

- the regular drainage of condensate

- cleaning the condensate collection trays
- cleaning the exhaust ducts

Airflow controls

Check:

- the regular flow of air
- cleaning of any intake grids
- cleaning the ducting

Cleaning

- cleaning of aesthetic cover
- cleaning or filter replacement
- cleaning the heat exchanger

Cleaning or filter replacement

To remove:

Size 30

1. Filter

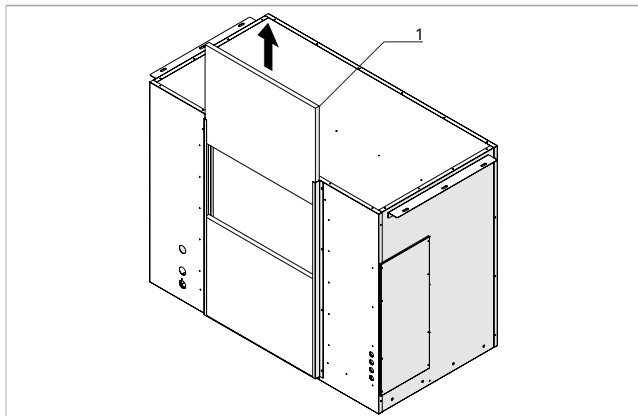

- disconnect the power supply to the unit
- remove the filter by gently sliding it upwards

To remove the filter from below:

Size 15

1. Lower filter guide
2. Filter

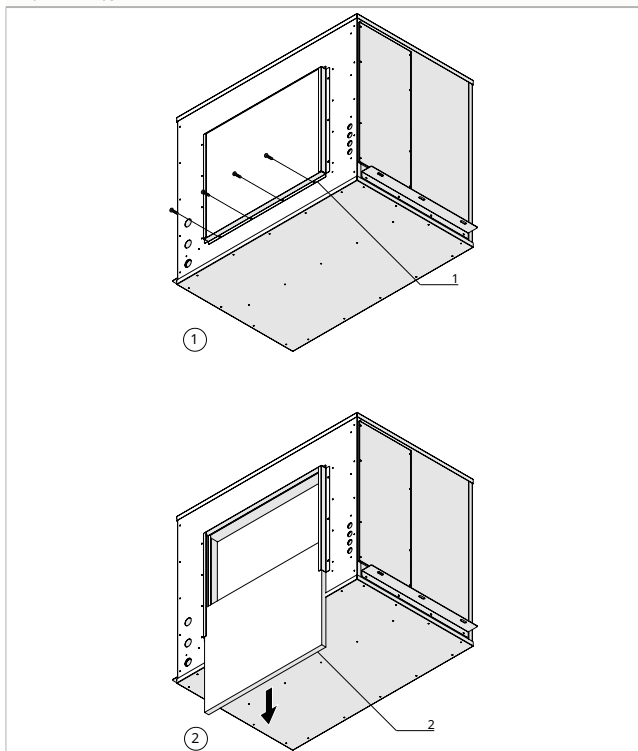

Size 30

1. Lower filter guide
2. Filter

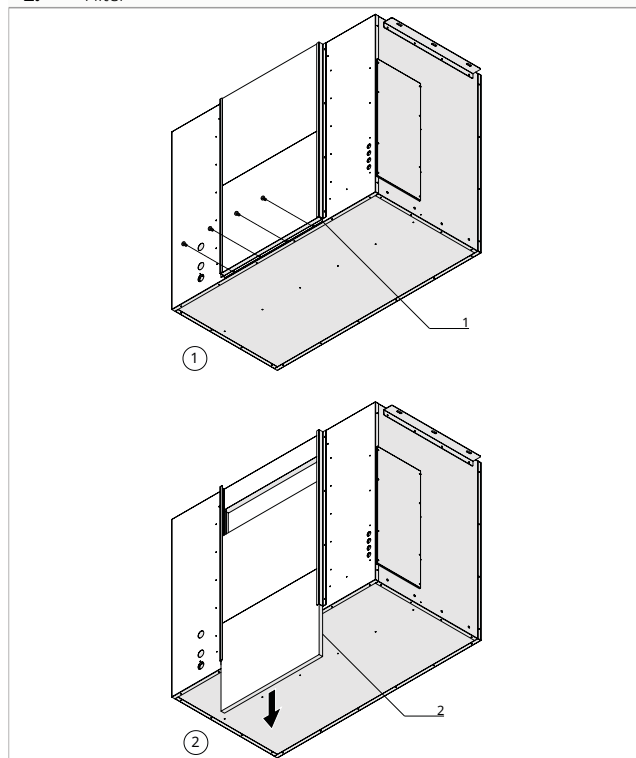

- disconnect the power supply to the unit
- remove the screws from the lower filter guide
- remove the lower filter guide

the filter automatically releases itself

⚠ Be careful to avoid damaging the filter during its extraction; maintain a firm yet gentle grip on the filter to ensure safe and controlled removal.

⚠ Pay attention to sharp surfaces

ⓘ If the condition of the filters is acceptable, they can be cleaned using a vacuum cleaner or a low-pressure compressor.

ⓘ If it is impossible to clean them, the filters must be replaced.

To reposition:

- proceed in reverse order

Cleaning the heat exchanger

Cleaning the heat exchanger

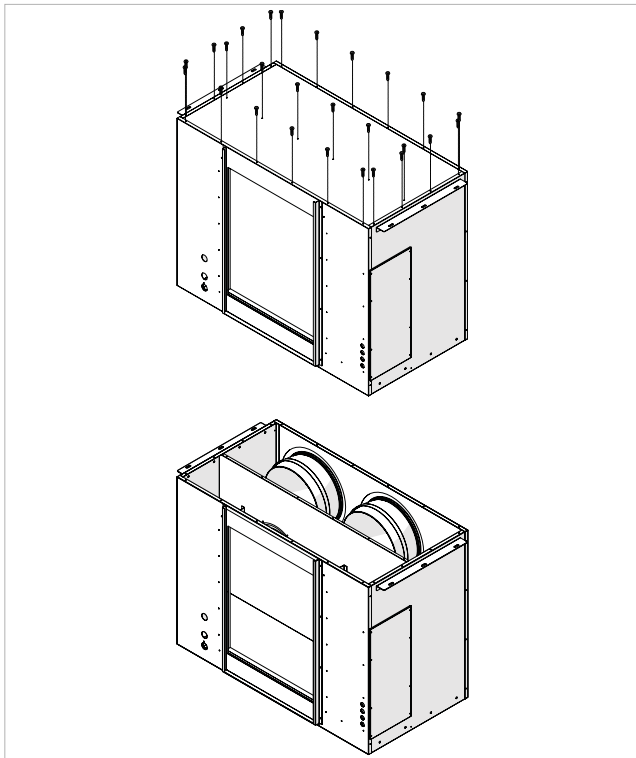

- disconnect the power supply to the unit
- disconnect the condensate drain pipe
- remove the filters (see chapter [p. 41](#))
- remove the screws from the upper panel
- remove the top panel
- gently proceed with cleaning using a vacuum cleaner or a low-pressure compressor
- reposition the top panel using the screws removed earlier
- reposition the filters

⚠ Never touch the fins of the heat exchanger, handle only the closed sides.

ⓘ To prevent dirt from entering the heat exchanger, clean in the opposite direction to the air flow.

FAULTS AND REMEDIES

Preliminary Warnings

If one of the following faults is found:

- the appliance is leaking water
- the appliance makes excessive noise
- there is dew formation on the front panel

Follow the instructions below:

- immediately disconnect the power supply

- close the water valves
- contact an authorised Technical Assistance Centre or professionally qualified personnel

⚠ Work must be carried out by a qualified installer or a specialised service centre.

⊘ Personal intervention is prohibited.

7.2 Anomalies reported by the control panel

Anomalies are reported on the display of the control panel.

⚠ For the reading, refer to the Control Panel Manual.

Manual reset of alarms

If an anomaly repeats multiple times, the device goes into safety mode, and the alarm must be manually reset.

⚠ To restore, refer to the Control Panel Manual.

7.3 Functional aspects not to be interpreted as faults

- During the operation of the device, the following functional aspects may occur. These unit behaviors are to be considered regular and should not be interpreted as anomalies.
- The compressor will not restart until 3 minutes have elapsed since it was switched off.
- While the heat pump appliances are heating up, heat is delivered a few minutes after the compressor is switched on.
- Periodic defrosting cycles occur during heating operation.
- When switching from producing domestic hot water to cooling, and vice versa, the external heat pump remains off for one minute to prevent mixing between hot and cold water.

Troubleshooting Table

ALARM	CAUSE	REMEDY
Environment intake probe alarm	The probe is damaged and/or disconnected	Verify that the probe has been connected correctly Replace the probe with a new one
Battery probe alarm	The probe is damaged and/or disconnected	Verify that the probe has been connected correctly Replace the probe with a new one
Intake probe alarm	The probe is damaged and/or disconnected	Verify that the probe has been connected correctly Replace the probe with a new one
Modbus communication alarm	The INN PDC 03 board is not communicating	Verify that the board has been connected correctly Replace the board with a new one
External unit alarm	There is an error on the external unit	Check for errors related to the external unit
SLAVE 1 alarm	Communication error with SLAVE No. 1	Check for the presence of SLAVE 1 Verify the correct connection
SLAVE 2 alarm	Communication error with SLAVE No. 2	Check for the presence of SLAVE 1 Verify the correct connection
SLAVE 3 alarm	Communication error with SLAVE No. 3	Check for the presence of SLAVE 1 Verify the correct connection
SLAVE 4 alarm	Communication error with SLAVE No. 4	Check for the presence of SLAVE 1 Verify the correct connection
SLAVE 5 alarm	Communication error with SLAVE No. 5	Check for the presence of SLAVE 1 Verify the correct connection
SLAVE 6 alarm	Communication error with SLAVE No. 6	Check for the presence of SLAVE 1 Verify the correct connection
SLAVE 7 alarm	Communication error with SLAVE No. 7	Check for the presence of SLAVE 1 Verify the correct connection

7.5 Alarms displayed on the control panel of the external unit

The control panel of the external unit allows for the display of alarms that occur during the operation of the heat pump.

⚠ If the user interface shows the PdC alarm, refer to the Technical Support Center.

Alarms displayed	Cause	Remedy
P03	Abnormal compressor discharge temperature > or = to 103 °C.	Check the refrigeration cycle (possible excessive refrigerant charge). Verify the opening of the refrigerant valves. Check the compressor discharge temperature probe (TD) and replace if necessary.
P04	High-pressure switch intervention on the external unit.	In the summer cycle, check the free circulation of air around the outdoor unit. Verify the refrigerant charge. In the winter cycle, check the opening of the refrigerant valves.
P05	Detection of absence of one phase or incorrect phase connection in the three-phase version. Lack of neutral in single-phase versions.	Check the presence and sequence of the power supply phases R, S, and T, and in single-phase systems ensure the appliance is not powered by two phases.
P10	Missing or disconnected electrical bridge on connector CN034 of the PAW-ACXA73-38670 board.	Check the connection.
P11	Ponte elettrico su connettore CN068 della scheda PAW-ACXA73-38670 mancante o scollegato.	Check the connection.
P15	Detection of insufficient refrigerant charge.	Check the refrigeration circuit for potential leaks.
P16	Excessive compressor absorption.	Check resistance values.
P19	4 way valve stuck	Check the power supply and the operation of the 4-way valve.
P20	Refrigerant high-pressure protection.	Check the cleanliness of the external heat exchanger and ensure minimum clearances are maintained. Check fan operation and proper discharge of air from the condenser.
P22	External fan motor malfunctioning. Protection of the external fan inverter circuit activated.	Check for free movement of the fan. Replace the fan motor inverter board.
P26	Intervention of the compressor inverter circuit protection.	Remove and restore power to the appliance and check the correct restart of the compressor.
P29	The compressor is not functioning correctly.	Check the wiring of the Inverter board and replace it if necessary.
H01	Overcurrent detected by the compressor's Inverter board.	The radiant plate cooling issue of the Inverter board. Check the cleanliness of the heatsink. Check the electrical connections of the compressor.
H05	The control board software of the external unit needs updating	Contact the Technical Support Center to arrange for the replacement.
H31	Malfunction of the HIC driver board	Contact the Technical Support Center to arrange for the replacement.
F01	The liquid sensor E1 on the indoor unit is disconnected, interrupted, or short-circuited.	Check the sensor and consider replacing it if needed.
F02	The condensation sensor E2 on the indoor unit is disconnected, interrupted, or short-circuited.	Check the sensor and consider replacing it if needed.
F04	The compressor discharge sensor TD is disconnected, interrupted, or short-circuited.	Check the sensor and consider replacing it if needed.
F06	The liquid sensor C1 on the outdoor unit's coil is disconnected, interrupted, or short-circuited.	Check the sensor and consider replacing it if needed.
F07	The condensation sensor C2 on the outdoor unit's coil is disconnected, interrupted, or short-circuited.	Check the sensor and consider replacing it if needed.
F08	The outdoor temperature sensor TO is disconnected, interrupted, or short-circuited.	Check the sensor and consider replacing it if needed.
F10	The regulation signal connection of the controller is disconnected, interrupted, or short-circuited.	Check the connection of the Tout connector and the controller INN-PDC_03 to the CN104 connector of the PAW-ACXA73-38670 board.
F12	The compressor suction sensor TS is disconnected, interrupted, or short-circuited.	Check the sensor and consider replacing it if needed.
F29	EEProm problem in the outdoor unit.	Switch the appliance off and on again and check for proper operation. Replace the EEPROM of the PAW-ACXA73-38670 board.
F31	EEProm problem in the outdoor unit.	Switch the appliance off and on again and check for proper operation. Replace and reprogram the electronic board of the outdoor unit.
L02	Parameter incompatibility between the indoor and outdoor unit.	Perform the automatic address setting again. Contact the Service for reprogramming.
L08	Lack of settings in the outdoor unit.	
L09	Lack of settings in the outdoor unit.	
L10	Lack of settings in the outdoor unit.	
L13	Incorrect parameter setting in the indoor unit.	

Alarms displayed	Cause	Remedy
L18	Malfunction of 4 way valve. The probes E1 and E2 detect low temperatures during heating. The probes E1 and E2 detect high temperatures during cooling.	It could be a transitory situation. Switch the appliance off and on again and check for proper operation.
E01	Automatic address setting was not completed. The wirings between the indoor and outdoor units are cut or not properly connected.	Check the connection between the indoor and outdoor units.
E03	Error in receiving signals from the indoor unit.	
E04	Error in receiving signals from the indoor unit.	
E06	Communication problems between the ourdoor and indoor units.	
E07	Communication problems between the ourdoor and indoor units.	
E15	The power of the indoor unit is lower than that of the outdoor unit.	Check the sizes of the unit and have the indoor unit reconfigured.
E16	The power of the outdoor unit is lower than that of the indoor unit.	Check the sizes of the unit and have the indoor unit reconfigured.
E20	Automatic addressing procedure interrupted.	Check the connection between the indoor and outdoor units.
E31	Communication problems between the ourdoor and indoor units.	

TECHNICAL INFORMATION

Technical data

Models	u.m.	OKKI 15 kW	OKKI 30 kW
Heating performance (A 7/6; A 20) (1)			
Nominal total output power	kW	13,40	28,00
Minimum total output power	kW	3,40	5,50
Maximum total output power	kW	16,00	29,00
COP	(2)	3,76	3,71
COP (maximum - minimum)	(2)	5,23÷3,03	5,00÷3,05
Cooling performance (A 35; A 27/19) (3)			
Nominal total output power	kW	13,40	23,20
Minimum total output power	kW	3,30	6,10
Maximum total output power	kW	15,00	27,00
EER	(2)	3,26	3,24
EER (maximum - minimum)	(2)	5,08÷2,93	4,59÷2,56
Airflow performance			
Nominal air flow rate	m ³ /h	2500	5000
Available pressure	Pa	170	170
Room side fan			
Type		Radial	
Number	No.	1	2
Maximum absorbed power	W	400	800
Sound levels			
Sound power radiated in the Lw channel	dB (A)	60,0	64,0
Average sound pressure at 5 m Lp	dB(A)	39,0	42,0
Electrical characteristics			
Power supply	V / ph / Hz	230 / 1 / 50	
Nominal absorbed power	kW	0,40	0,80
Total absorbed current	A	1,83	3,66
Protection rating	IP	X2	
Product dimensions			
Width	mm	1010	1360
Depth	mm	893	953
Height	mm	802	1026
Weight	kg	75,0	97,0
Connections			
Air connections	mm	355	355
Condensate drain connection	mm	30	30
1. Outdoor air temperature: 7 °C b.s. and 6 °C b.u.; Indoor air temperature: 20 °C 2. EER and COP Classification according to EN14511 directive 3. Outdoor air temperature: 35 °C b.s.; Indoor air temperature. 27 °C b.s. and 19 °C b.u.			

		Outdoor unit	
Models	u.m.	15 kW	30 kW
Heating airflow performance			
Maximum flow rate	m ³ /h	6960	9600
Cooling airflow performance			
Maximum flow rate	m ³ /h	7740	9600
Compressor			
Type		Rotary inverter	
Number	No.	1	1
Refrigerant type		R32	
Refrigerant quantity	kg	3,05	5,20
Heating sound levels			
Sound power transmitted to the Lw structure	dB (A)	71,0	82,0
Average sound pressure at 1 m Lp	dB(A)	54,0	63,0
Cooling sound levels			
Sound power transmitted to the Lw structure	dB (A)	71,0	78,0
Average sound pressure at 1 m Lp	dB(A)	54,0	59,0
Electrical characteristics			
Power supply	V / ph / Hz	400 / 3 / 50	
Maximum total absorbed power	kW	5	9
Maximum total absorbed current	A	7,60	13,67
Protection rating	IP	X4	
Limits in heating			
Minimum outdoor air temperature	°C	-15,0	-20,0
Maximum outdoor air temperature	°C	48,0	24,0
Limits in cooling			
Minimum outdoor air temperature	°C	-20,0	-15,0
Maximum outdoor air temperature	°C	24,0	46,0
Product dimensions			
Width	mm	940	980
Depth	mm	340	370
Height	mm	1416	1500
Weight	kg	98,0	128,0
Connections			
Liquid connection	"SAE	3/8	1/2
Gas connection	"SAE	5/8	1

Dimensions

8.2.1 Size 15

- A** Power supply
- B** Refrigerant connections
- C** Condensate drain

- D** Filter
- E** Electrical panel

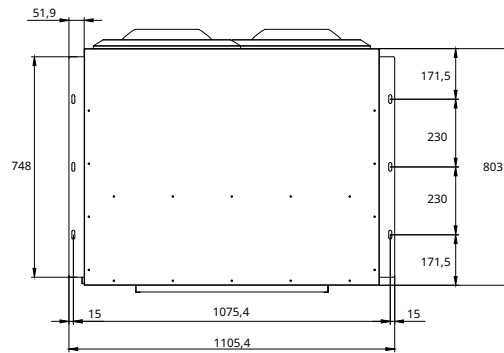
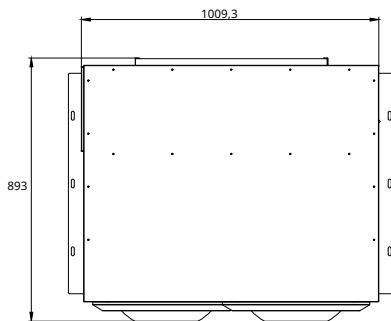
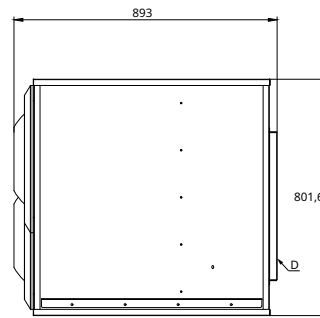
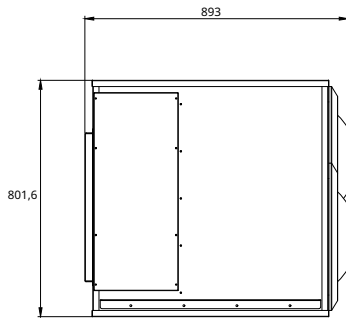
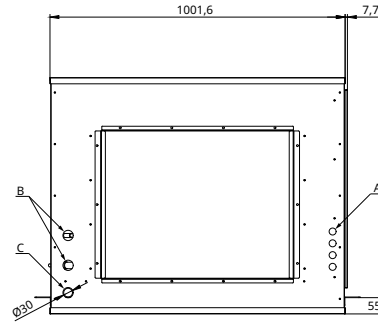
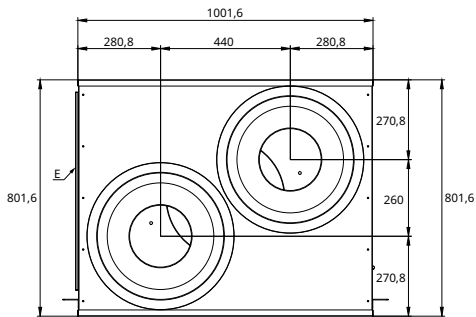

8.2.2 Size 30

- A** Power supply
- B** Refrigerant connections
- C** Condensate drain

- D** Filter
- E** Electrical panel

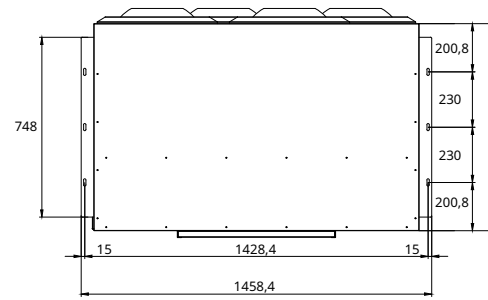
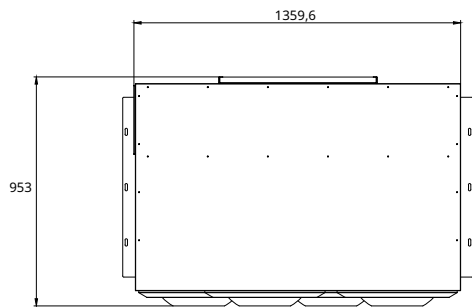
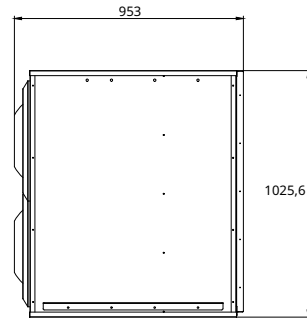
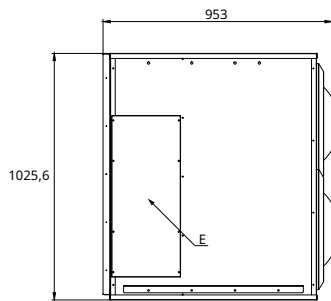
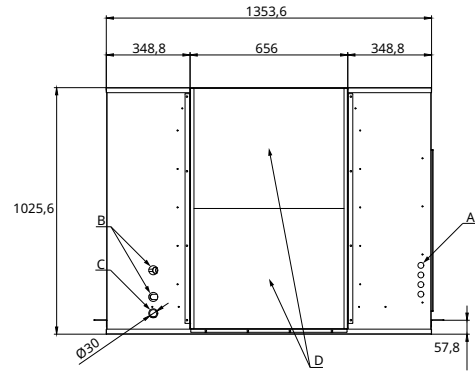
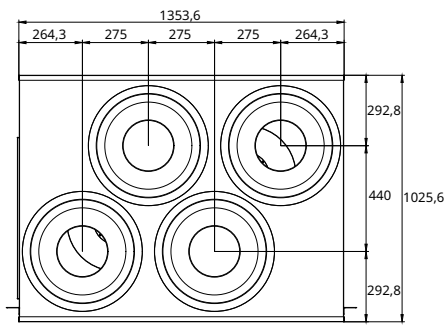

INNOVA S.r.l.
Via I Maggio 8 - 38089 (TN) - ITALY
tel. +39.0465.670104 - fax +39.0465.674965
info@innovaenergie.com