



innova

N421039A - Rev. 01 - 01/2024

DUCTO

First of all, we would like to thank you for having chosen one of our units.

As you will realise, you have made a winning choice by purchasing a product that represents the state of the art in domestic air-conditioning technology.

Thanks to the product you have purchased and by following the suggestions in this manual, you will benefit from optimal environmental conditions with the lowest possible energy investment.

Compliance

This unit complies with European directives:

- Low voltage 2014/35 / EU
- Electromagnetic compatibility 2014/30 / EU

Markings



CONTENTS

1	General information	<u>p. 5</u>
1.1	About the manual	<u>p. 5</u>
1.2	General Warnings	<u>p. 6</u>
1.3	Basic safety rules	<u>p. 6</u>
1.4	Disposal	<u>p. 7</u>
2	Product introduction	<u>p. 8</u>
2.1	Identification	<u>p. 8</u>
2.2	Destination of use	<u>p. 8</u>
2.3	Description of the appliance	<u>p. 8</u>
2.4	List of external components	<u>p. 9</u>
2.5	List of internal components	<u>p. 9</u>
2.6	Configurations	<u>p. 10</u>
2.7	Compatible accessories	<u>p. 11</u>
3	Installation	<u>p. 13</u>
3.1	Preliminary Warnings	<u>p. 13</u>
3.2	Reception	<u>p. 13</u>
3.3	Dimensions and weights with packaging	<u>p. 13</u>
3.4	Handling with packaging	<u>p. 14</u>
3.5	Storage	<u>p. 14</u>
3.6	Unpacking	<u>p. 14</u>
3.7	Handling without packaging	<u>p. 15</u>
3.8	Installation site	<u>p. 15</u>
3.9	Minimum installation distances	<u>p. 16</u>
3.10	Positioning	<u>p. 18</u>
3.11	Hydraulic connections	<u>p. 19</u>
3.12	Condensate drain connection	<u>p. 22</u>
3.13	System charging	<u>p. 23</u>
3.14	Aeraulic connections	<u>p. 23</u>
3.15	Electrical connections	<u>p. 29</u>
4	Remote control	<u>p. 32</u>
4.1	Installation	<u>p. 32</u>
4.2	Electrical connections	<u>p. 33</u>
4.3	Interface	<u>p. 35</u>
4.4	Warnings	<u>p. 37</u>
5	Start-up	<u>p. 38</u>
5.1	Preliminary Warnings	<u>p. 38</u>
5.2	First start-up	<u>p. 38</u>
5.3	Plant delivery	<u>p. 39</u>
5.4	Switching off for extended periods	<u>p. 39</u>

6	Maintenance	<u>p. 40</u>
6.1	Routine maintenance	<u>p. 40</u>
7	Faults and remedies	<u>p. 43</u>
7.1	Preliminary Warnings	<u>p. 43</u>
7.2	Troubleshooting Table	<u>p. 43</u>
7.3	Alarm table and card flashes	<u>p. 44</u>
8	Technical information	<u>p. 45</u>
8.1	Technical data	<u>p. 46</u>
8.2	Dimensions.	<u>p. 49</u>

GENERAL INFORMATION

1.1 About the manual

This manual was written to provide all the explanations for the correct management of the appliance.

- ⚠ This instruction manual is an integral part of the appliance and must therefore be kept in a safe place and must ALWAYS accompany the appliance even if it is passed on to another owner or user, or transferred to another plant. If it is damaged or lost, download a copy from the website.
- ⚠ Read this manual carefully before proceeding with any operation and follow the instructions in the individual chapters.
- ⚠ Specific warnings are given in each chapter of the document and should be read before starting operations.
- ⚠ The manufacturer accepts no liability for damage to persons or property resulting from failure to observe the regulations contained in this booklet.
- ⚠ This document is confidential under the terms of the law and may not be reproduced or passed on to third parties without the express authorisation of the company.

1.1.1 Editorial pictograms

The pictograms in the following chapter provide quick and unambiguous information necessary for the correct and safe use of the machine.

Related to safety

- ⚠ **High risk warning (bold text)**
 - The operation described above presents a risk of serious physical injury, fatality, major damage to the appliance and/or to the environment if not carried out in compliance with safety regulations.
- ⚠ Low risk warning (plain text)
 - The operation described above presents a risk of minor physical injury or minor damage to the appliance and/or to the environment if not carried out in compliance with safety regulations.
- 🚫 Prohibition (normal text)
 - Marks actions that absolutely must not be done.
- ❗ **Important information (bold text)**
 - This indicates important information that must be taken into account during the operations.

In the texts

Purpose of the actions

- Actions required

Expected responses following an action

- Lists

In the figures

- 1 The numbers indicate the individual components.
- A Capital letters indicate a combination of components and dimensions.
- ① The white numbers in black marks indicate a series of actions to be carried out in sequence.
- Ⓐ The black letter in white identifies an image when there are several images in the same figure.

1.1.2 Pictograms on the product

Symbols are used in some parts of the appliance:

Related to safety

⚠ Attention electrical hazard

- Warns relevant personnel of the presence of electricity and the risk of electric shock.

1.1.3 Recipients

User

Non-expert person capable of operating the product in safe conditions for people, for the product itself and the environment, interpreting an elementary diagnostic of faults and abnormal operating conditions, carrying out simple adjustment, checking and maintenance operations.

Installer

Expert person qualified to position and connect (hydraulically, electrically, etc.) the unit to the plant; this person is responsible for handling and correct installation according to the instructions provided in this manual and the national standards currently in force.

Service

Expert and qualified person authorised directly by the manufacturer to carry out all routine and supplementary maintenance operations, as well as every adjustment, check, repair and replacement of parts necessary during the life of the unit itself.

1.1.4 Organisation of the manual

The manual is divided into sections each dedicated to one or more target groups.

General information

It addresses all recipients.

It contains general information and important warnings that should be known before installing and using the appliance.

Product introduction

Addressed to all recipients, contains general information on the product.

Installation and Operation

It is addressed exclusively to the installer.

Contains specific warnings and all information necessary for positioning, mounting, connecting the device and operation.

Commissioning, maintenance and troubleshooting

They are addressed exclusively to the Technical Assistance Centre.

It contains specific warnings useful information for the most common commissioning and routine maintenance.

Technical information

It addresses all recipients.

It contains detailed technical information about the appliance.

1.2 General Warnings

- ⚠ Specific warnings are given in each chapter of the document and should be read before starting operations.
- ⚠ All personnel involved must be aware of the operations and dangers that may arise when beginning all unit installation operations.
- ⚠ Installation performed outside the warnings provided in this manual and use of the appliance outside the prescribed temperature limits will invalidate the warranty.
- ⚠ Any contractual or extra-contractual liability for damage caused to persons, animals or property, due to installation, adjustment and maintenance errors or improper use is excluded. All uses not expressly indicated in this manual are not permitted.
- ⚠ The installation of the appliances must be carried out by a qualified company which, on completion of the work, will issue a declaration of compliance to the person in charge of the plant in accordance with the regulations in force and the instructions provided in the instruction booklet accompanying the appliance.
- ⚠ First start-up and repair or maintenance operations must be carried out by the Technical Assistance Centre

or by qualified personnel following the provisions of this manual.

- ⚠ Do not modify or tamper with the appliance as this can lead to dangerous situations.
- ⚠ Use suitable accident-prevention clothing and equipment during installation and/or maintenance operations. The manufacturer is not liable for the non-observance of the current safety and accident prevention regulations.
- ⚠ In the event of spillage of liquids, oil, set the system's main switch to "off" and close any water taps. Call the authorised Technical Assistance Centre or professionally qualified personnel as soon as possible and do not work on the appliance yourself.
- ⚠ When replacing components, use only original spare parts.
- ⚠ The manufacturer reserves the right to make changes to its models at any time to improve its product, without prejudice to the essential characteristics described in this manual. The manufacturer is not obliged to add such modifications to machines previously manufactured, already delivered or under construction.

1.3 Basic safety rules

We would like to remind you that the use of products that use electricity and water involves observing certain basic safety precautions such as:

- ⊖ It is forbidden for children and unassisted disabled persons to use the appliance.
- ⊖ It is forbidden to touch the appliance with wet or damp body parts.
- ⊖ It is forbidden to carry out any operation before disconnecting the appliance from the power supply by setting the plant master switch to "off".
- ⊖ It is forbidden to modify the safety or adjustment devices without the authorisation and instructions of the appliance manufacturer.
- ⊖ It is forbidden to pull, unplug or twist the electrical cables coming out of the appliance, even if it is disconnected from the mains supply.
- ⊖ It is forbidden to introduce objects and substances through the air intake and outlet grilles.
- ⊖ It is forbidden to open the access doors to the internal parts of the appliance without first setting the plant master switch to "off".
- ⊖ It is forbidden to dispose of packaging material and leave it within reach of children as it can be a potential source of danger.

1.4 Disposal

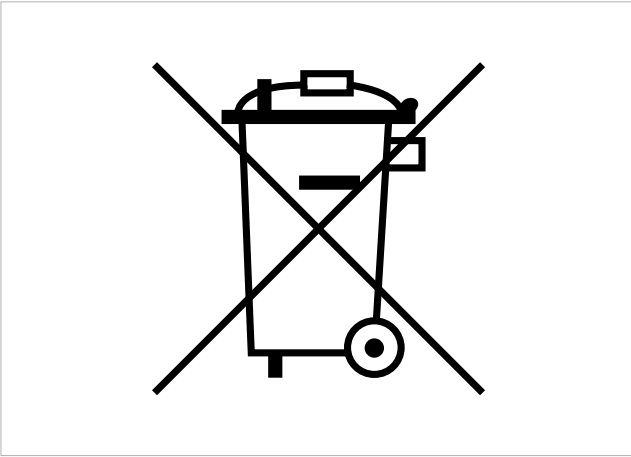

The symbol on the product or its packaging indicates that the product must not be treated as normal household waste, but must be taken to the appropriate collection point for the recycling of electrical and electronic equipment.

Proper disposal of this product avoids harm to humans and the environment and promotes the reuse of valuable raw materials.

For more detailed information about the recycling of this product, contact your local city office, your household waste disposal service or the shop where you purchased the product.

Illegal disposal of the product by the user involves the application of the administrative sanctions provided for by the regulations in force.

This provision is only valid in the EU Member States.

⚠ Avoid disassembling the appliance yourself.

⚠ **Contact an authorised Technical Assistance Centre to disassemble the appliance.**

PRODUCT INTRODUCTION

2.1 Identification

The appliance can be identified by the rating plate:

1. Technical rating plate

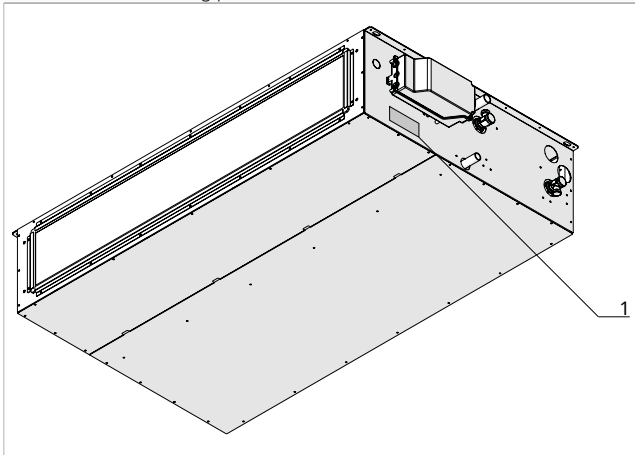

Technical rating plate

This shows the technical and performance specifications of the appliance.

⚠ Tampering with, removing or missing identification plates does not allow the product to be reliably identified by its serial number and therefore invalidates the warranty.

2.2 Destination of use

FNC is a compact unit for air conditioning systems suitable for horizontal ceiling or vertical wall installation.

2.3 Description of the appliance

Structure: high-strength, self-supporting frame in galvanized sheet metal with internal thermal and acoustic insulation.

Fans: low-energy consumption forward-curved EC centrifugal fans for reduced noise.

Filters: flat with Coarse filtration class.

Exchange coil: coil optimized for the best heat exchange

Models: 5 sizes with different flow rates are available.

Versions:

- Electronic board I
- Electronic board S

2.4 List of external components

- | | | | |
|----|--|----|--|
| 1. | Horizontal condensate drain installation | 4. | Hydraulic connection water inlet to the unit including air vent |
| 2. | Electrical panel | 5. | Hydraulic connection water outlet from the unit including air vent |
| 3. | Vertical condensate drain installation | | |

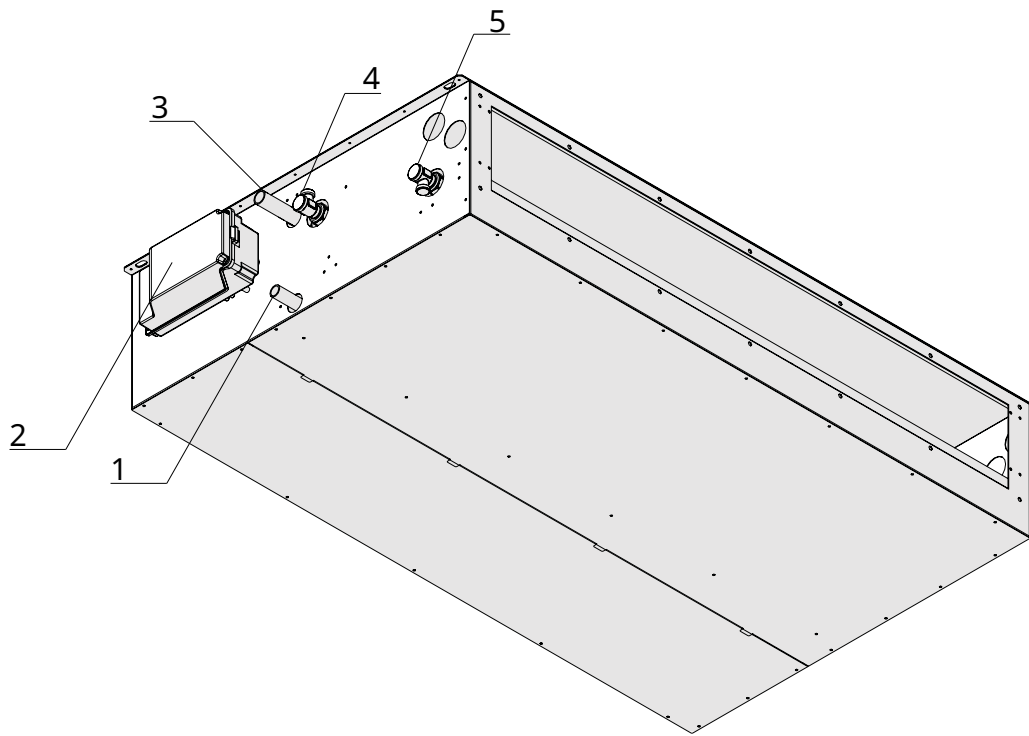

2.5 List of internal components

- | | | | |
|----|--------|----|---------------|
| 1. | Fan | 3. | Hydronic coil |
| 2. | Filter | | |

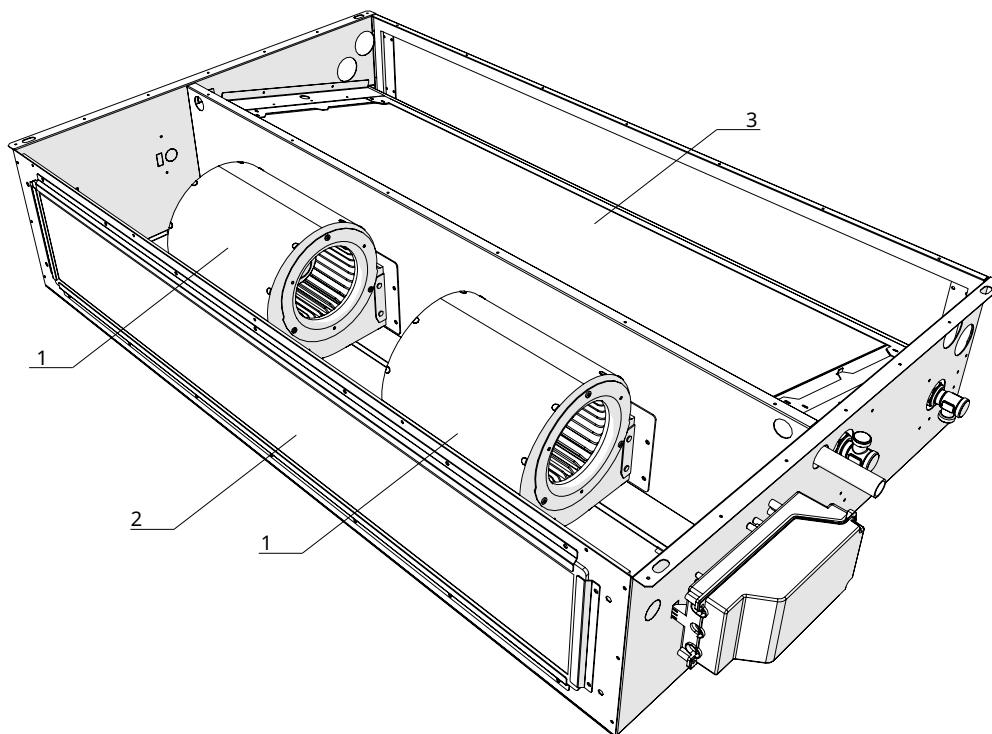

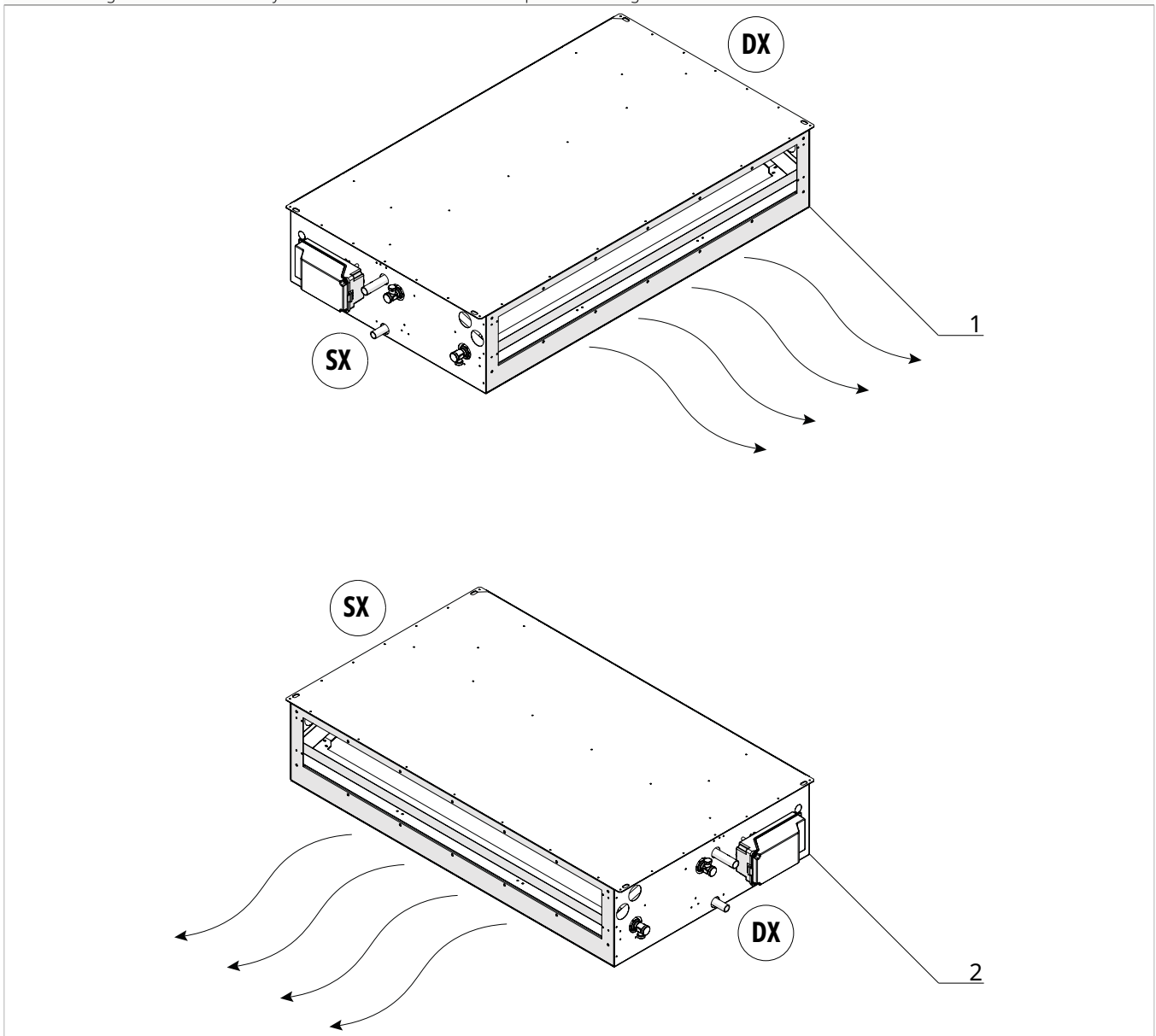

2.6 Configurations

- 1. Configuration O: hydraulic connections and electrical panel on the left
- 2. Configuration Y: hydraulic connections and electrical panel on the right

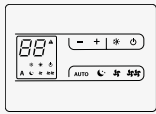

2.7 Compatible accessories

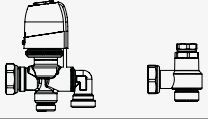
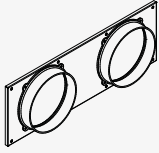
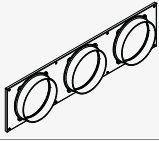
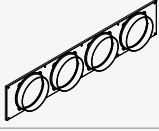
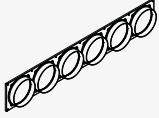
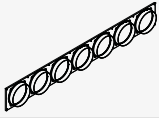
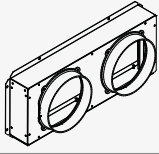
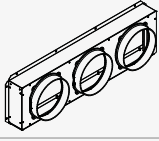
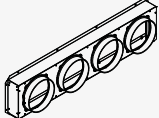
Description	Code	
Commands for I versions		
	CNW2-B Black Digital Remote Control with Temperature Sensor and Wi-Fi	AHRP0635
	CNW2-W White Digital Remote Control with Temperature Sensor and Wi-Fi	AHRP0636
	CNV2-B Black Digital Remote Control with Temperature Sensor and Modbus Rs485	AHRP0631
	CNV2-B White Digital Remote Control with Temperature Sensor and Modbus Rs485	AHRP0632
Water valves		
	KIT2 Motorized On-Off 2-way Zone Valve 3/4"	AHRP0013
	KIT3 Motorized On-Off 3-way Zone Valve 3/4"	AHRP0014
FNC input plate		
	Supply plate with 2 circular inlets 160mm	AHRD0431
	Supply plate with 3 circular inlets 160mm	AHRD0432
	Supply plate with 4 circular inlets 160mm	AHRD0433
	Supply plate with 6 circular inlets 160mm	AHRD0434
	Supply plate with 7 circular inlets 160mm	AHRD0435
FNC recirculation plenum		
	Return plenum with 2 circular inlets 160mm	AHRD0461
	Return plenum with 3 circular inlets 160mm	AHRD0462
	Return plenum with 4 circular inlets 160mm	AHRD0463

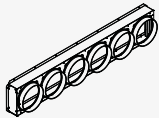
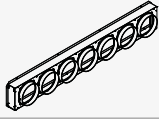
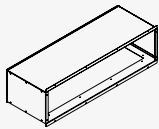
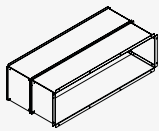
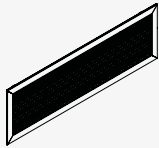
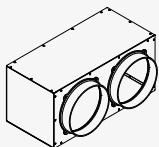
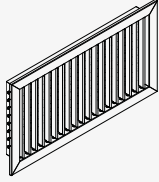
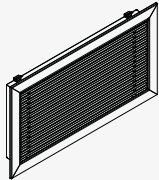
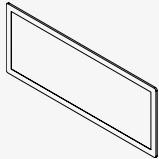
Description		Code
	Return plenum with 6 circular inlets 160mm	AHRD0464
	Return plenum with 7 circular inlets 160mm	AHRD0465
Suction duct plenum		
	Rear suction plenum kit for FNC 40	AHRD0521
	Rear suction plenum kit for FNC 60	AHRD0522
	Rear suction plenum kit for FNC 80	AHRD0523
	Rear suction plenum kit for FNC 100	AHRD0524
	Rear suction plenum kit for FNC 120	AHRD0525
Telescopic kit		
	Telescopic kit for rear or direct suction for FNC 40	AHRD0531
	Telescopic kit for rear or direct suction for FNC 60	AHRD0532
	Telescopic kit for rear or direct suction for FNC 80	AHRD0533
	Telescopic kit for rear or direct suction for FNC 100	AHRD0534
	Telescopic kit for rear or direct suction for FNC 120	AHRD0535
Grilles for telescopic kit		
	Grille for telescopic kit for FNC 40	AHRD0541
	Grille for telescopic kit for FNC 60	AHRD0542
	Grille for telescopic kit for FNC 80	AHRD0543
	Grille for telescopic kit for FNC 100	AHRD0544
	Grille for telescopic kit for FNC 120	AHRD0545
Distribution accessories		
	Insulated plenum for horizontal or vertical supply/return with two DN160 inlets and grille connection (410 x 175 x 175 mm)	AHRA0708
	White aluminum supply grille with double row of adjustable fins (450x225 mm)	AHRA0709
	White aluminum intake grille with removable filter (450x225 mm)	AHRA0710
Standard filters		
	FDR - Replacement recirculation filter kit for FNC 40	AHRD0491
	FDR - Replacement recirculation filter kit for FNC 60	AHRD0492
	FDR - Replacement recirculation filter kit for FNC 80	AHRD0493
	FDR - Replacement recirculation filter kit for FNC 100	AHRD0494
	FDR - Replacement recirculation filter kit for FNC 120	AHRD0495

INSTALLATION

3.1 Preliminary Warnings

- ⚠ **For detailed information on the products, refer to chapter 8 p. 45.**
- ⚠ The installation must be carried out by the installer. There is a risk of water leakage, electric shock or fire if the installation is not performed correctly.
- ⚠ During installation, it is necessary to observe the precautions mentioned in this manual, and on the labels affixed to the inside of the appliances, as well as to take

every precaution suggested by common sense and the safety regulations in force at the place of installation.

- ⚠ Using only the supplied installation-specific components is recommended. Use of different components could lead to water leakage, electric shock or fire.
- ⚠ Failure to apply the indicated rules may cause malfunctions of the appliances and relieves the manufacturer from any warranty and from any damage caused to persons, animals or property.

3.2 Reception

3.2.1 Preliminary Warnings

- ⚠ Upon receipt of the package check that it is not damaged, otherwise accept the goods with reserve, producing photographic evidence of any damage.
- ⚠ In the event of damage, notify the shipper by registered mail with return receipt within 3 days of receipt. Presenting photographic documentation, similar information should also be sent by fax to the manufacturer.

- ⚠ No reports of damage will be taken into account later than 3 days after delivery.

3.2.2 Package description

The packaging is made of suitable material and carried out by experienced personnel. The units are all checked and tested and are delivered complete and in perfect condition. The appliance is shipped in standard packaging consisting of a cardboard box and a set of polystyrene foam protectors, placed on a wooden pallet and secured with straps.

3.3 Dimensions and weights with packaging

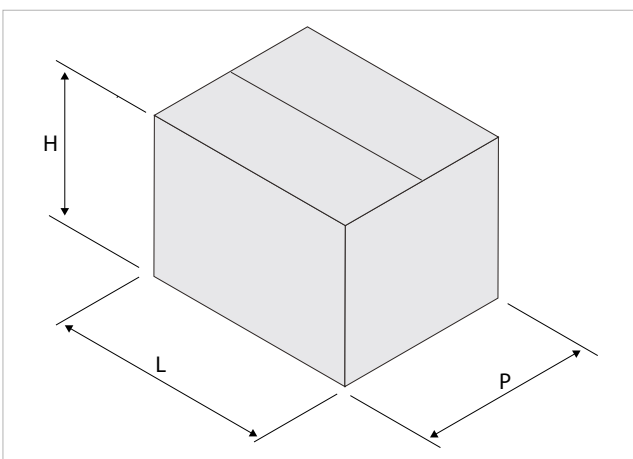

Models	u.m.	40	60	80	100	120
Packaging dimensions (1)						
Width	mm	890	890	890	890	795
Length	mm	735	935	1135	1335	1660
Height	mm	285	285	285	285	285
Weight	kg	24,0	27,0	35,0	40,0	52,0
1. Excluding pallet						

3.4 Handling with packaging

3.4.1 Preliminary Warnings

- ⚠ The unit may only be handled by qualified personnel adequately equipped and with equipment suitable for the weight and dimensions of the unit.
- ⚠ Before each handling operation, check the lifting capacity of the machinery used in accordance with the indications on the packaging.

3.4.2 Handling

With pallet:

- use a forklift

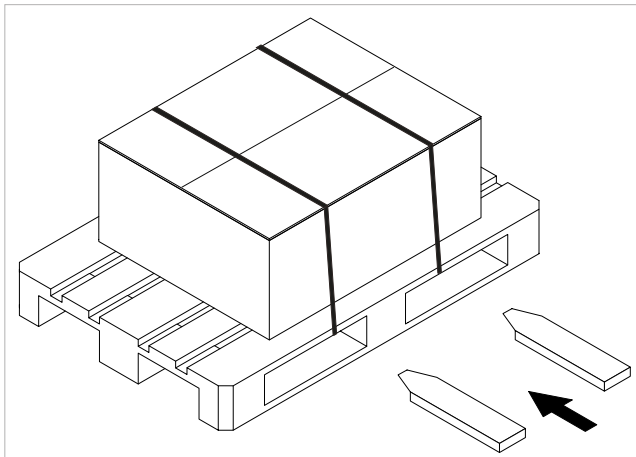

- ⚠ When the load is lifted from the ground, stay clear of the immediate and surrounding area.
- ⚠ Check the information on the packaging for the amount of stackable packages.
- ⚠ In manual operations, the maximum weight per person required by current legislation must always be observed.

Without pallet:

- use a forklift

- ⚠ The unit can only be moved manually for short trips in exceptional cases. In this case it is necessary to carefully check that the weight of the unit does not exceed what is stipulated by the regulations with respect to the number of people employed.

3.5 Storage

3.5.1 Preliminary Warnings

- ⚠ Stored in accordance with the applicable national regulations.

- ⚠ Store in a closed environment protected from the weather, off the ground by means of sleepers or pallets with temperatures not below 0 °C, up to a maximum of 40 °C.

3.6 Unpacking

3.6.1 Preliminary Warnings

- ⚠ Check that the individual components are present.
- ⚠ Check that no components were damaged during transport.
- ⚠ Dispose of the packaging components following the applicable waste disposal regulations. Check for disposal arrangements with your municipality.
- ⚠ Handle with care.
- ⊘ The packing material (cardboard, staples, plastic bags, etc.) must not be dispersed or abandoned in the surrounding environment and must be kept out of children reach, as it can be dangerous.

3.6.2 Removing the packaging

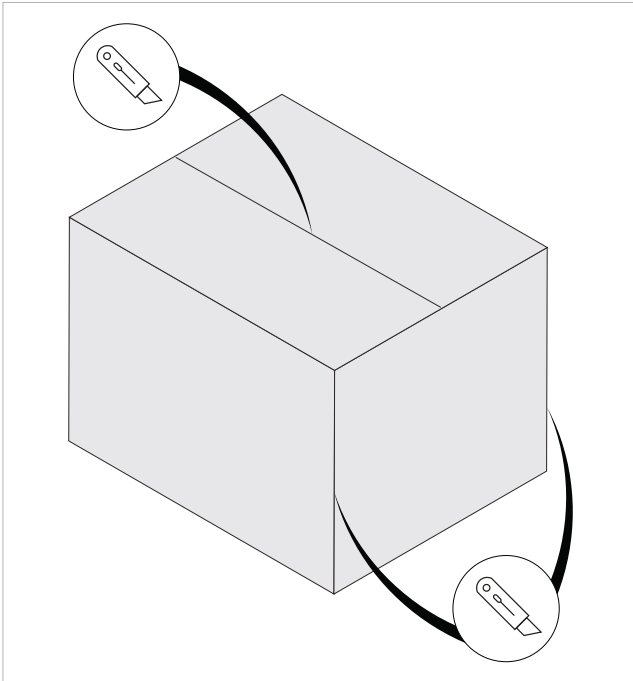

To remove the packaging:

- use a cutter
- open the cardboard packaging
- ⓘ To aid removal of the product, also cut the vertical edges.
- remove the accompanying components
- remove the polystyrene elements
- remove the appliance from the box

Accompanying material

They are included with the appliance, inside the packaging:

- Installer manual
- Labels/stickers provided on the unit
- ⚠ Check the presence of the individual components.

3.7 Handling without packaging

3.7.1 Preliminary Warnings

- ⚠ The appliance must be handled only by qualified personnel, adequately equipped and with equipment suitable for the weight and dimensions of the appliance.
- ⚠ The unit must be handled using non-slip gloves.
- ⚠ The unit may only be handled by qualified personnel adequately equipped and with equipment suitable for the weight and dimensions of the unit.
- ⚠ Before each handling operation, check the lifting capacity of the machinery used in accordance with the indications on the packaging.
- ⚠ When the load is lifted from the ground, stay clear of the immediate and surrounding area.

- ⚠ Check the information on the packaging for the amount of stackable packages.
- ⚠ In manual operations, the maximum weight per person required by current legislation must always be observed.

3.7.2 Movement methods

- use a fork lift, scaffolding or other suitable lifting system
- ⚠ The unit can only be moved manually for short trips in exceptional cases. In this case it is necessary to carefully check that the weight of the unit does not exceed what is stipulated by the regulations with respect to the number of people employed.

3.8 Installation site

The location of the appliance must be determined by the plant engineer or a competent person and must take into account both purely technical requirements and any national/local legislation in force.

The appliance is intended to be installed indoors:

- in a horizontal position fixed to the ceiling.
- in a vertical position fixed to the wall.
- ⚠ The installation position must be chosen close to a wall connected to the outside.
- ⚠ The appliance is declared IPX0 protected, therefore not suitable for installation outdoors or in rooms with the presence of water (swimming pool, etc.).

3.8.1 Preliminary Warnings

- ⚠ Avoid installing the unit in the vicinity of:
 - obstacles or barriers that cause recirculation of the exhaust air
 - narrow places where the sound level of the appliance can be enhanced by reverberations or resonances
 - environments with the presence of flammable or explosive gases
 - very damp environments (laundries, greenhouses, bathrooms with high humidity, etc.) to prevent the formation of condensation on the external panels of the unit

- environments with the presence of flammable or explosive gases or flammable fluids
- solar radiation and proximity to heat sources

⚠ Avoid installing the unit in the vicinity of the sea. Salty atmospheres cause corrosion and oxidation of the internal components, compromising the functioning of the unit.

⚠ Avoid placing the unit within 1 metre of radio and video equipment.

⚠ Do not install above heat sources.

⚠ Ensure that:

- the installation site of the unit must be chosen with the utmost care to guarantee adequate protection from shocks and consequent damage
- the supporting surface is capable of supporting the weight of the appliance
- the supporting surface does not affect load-bearing building elements, piping or power lines

- the functionality of load-bearing elements is not compromised
- there are no obstacles to the free circulation of air through the holes (plants, leaves...)

• the appliance must be installed in a position where it can be easily serviced

• the safety distances between the units and other appliances or structures are scrupulously respected so that the air entering and leaving the fans is free to circulate

⚠ If the unit is installed incompletely or on an unsuitable surface, it could cause damage to persons or property if it becomes detached.

⚠ The appliance must not be in a position where the air flow is aimed directly at a person.

⚠ Provide the following:

- a drain nearby for the outflow of condensation
- a compliant power supply nearby
- fastening elements suitable for the type of support

3.9 Minimum installation distances

The clearance zones for the installation and maintenance of the appliance are shown in the figure. Established spaces are necessary to avoid barriers to airflow and allow for normal cleaning and maintenance.

⚠ Make sure that there is sufficient space to allow the panels to be removed for routine and supplementary maintenance operations.

Horizontal installation

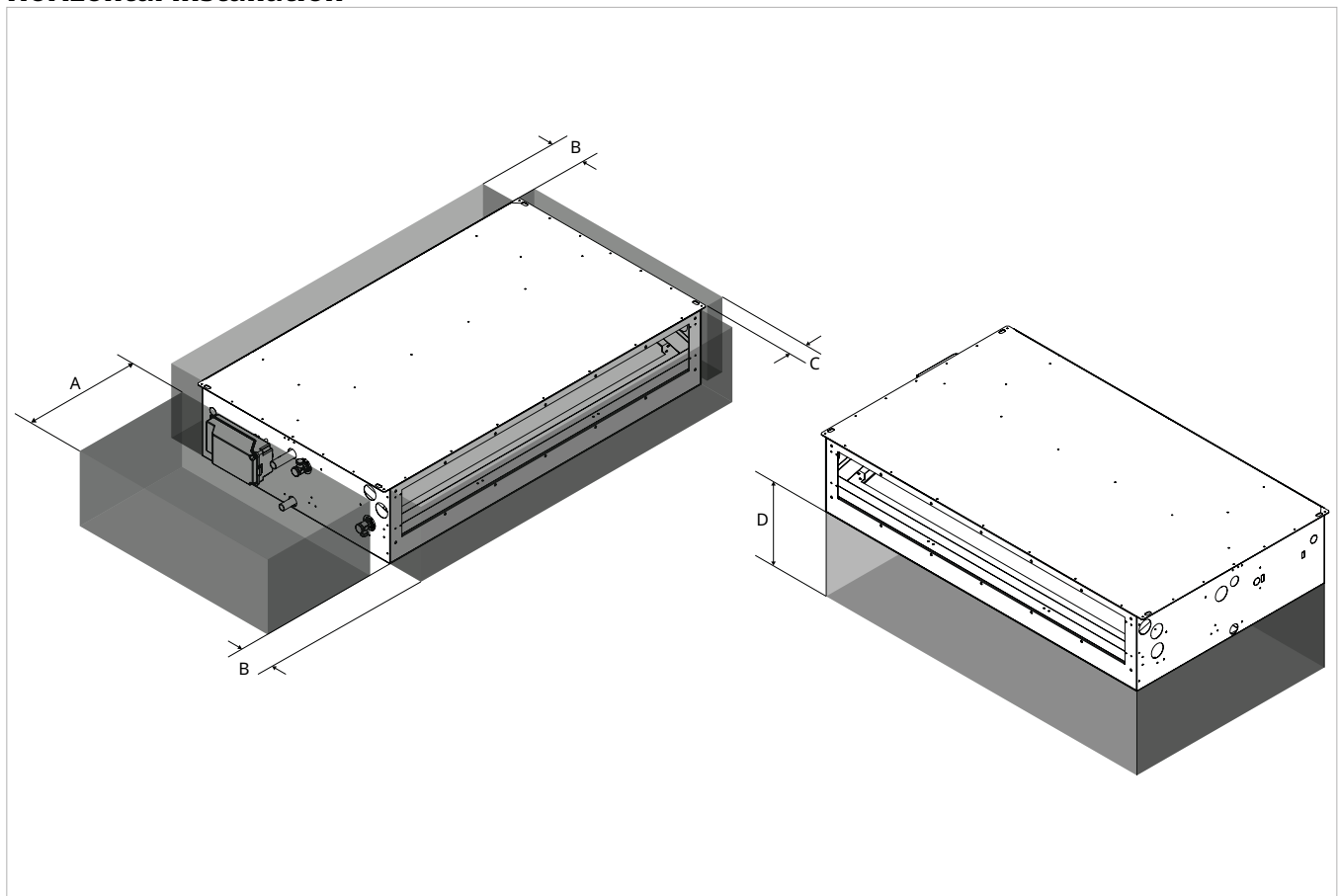

Vertical installation

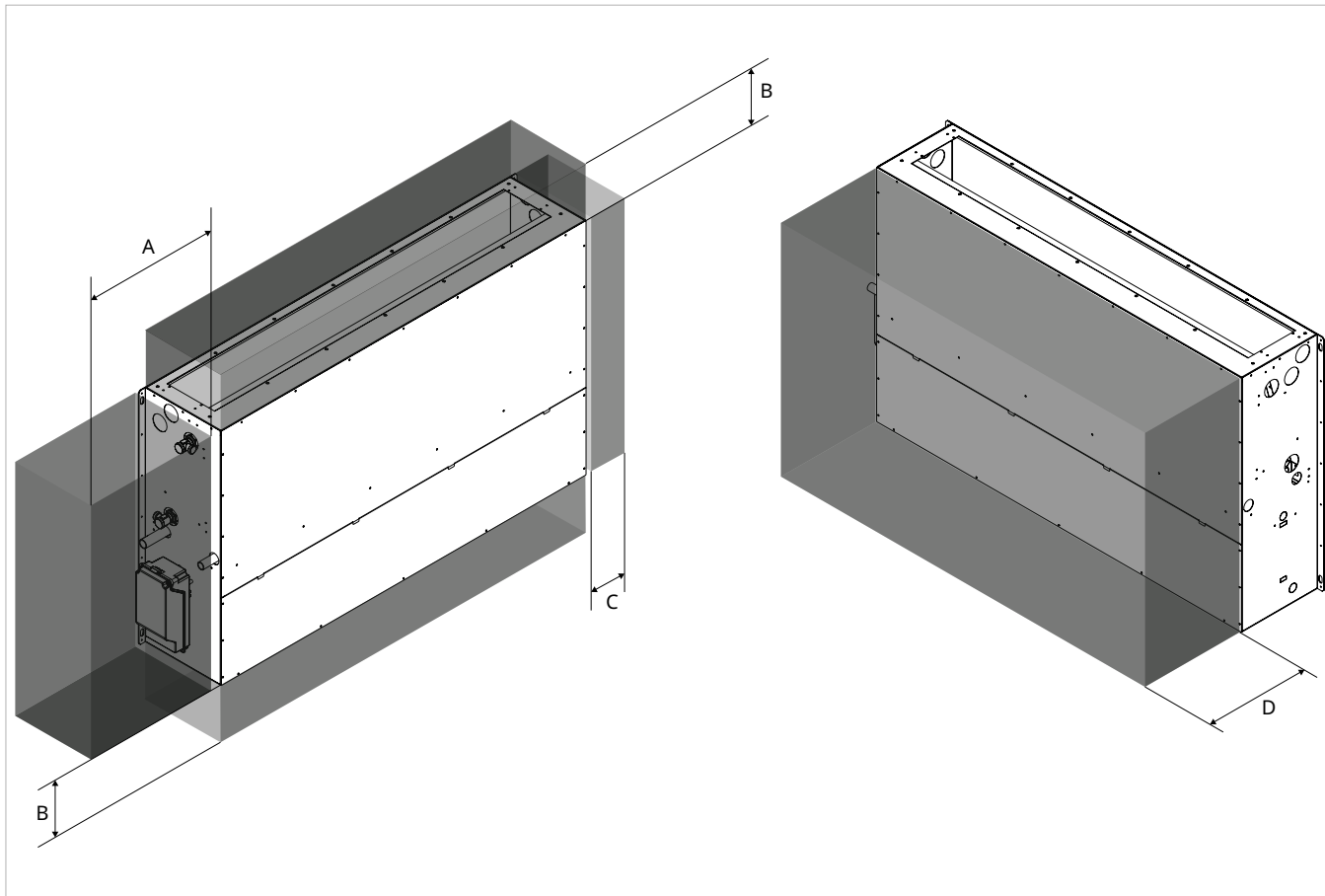

Models	u.m.	40	60	80	100	120
Minimum distances						
A	mm	350	350	350	350	350
B	mm	100	100	100	100	100
C	mm	50	50	50	50	50
D	mm	250	250	250	250	250

3.9.1 Hatch dimensions

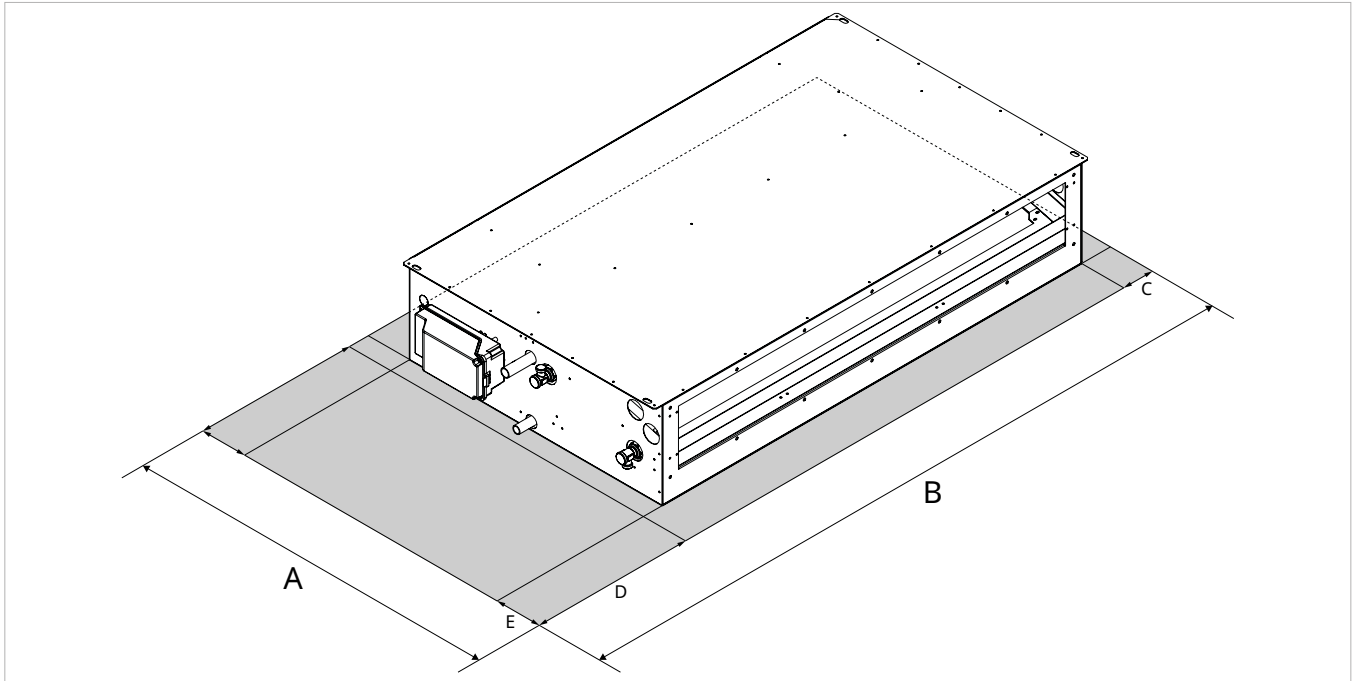

Models	u.m.	40	60	80	100	120
Hatch dimensions						
A	mm	895	895	895	895	895
B	mm	990	1190	1390	1590	1840
C	mm	50	50	50	50	50
D	mm	350	350	350	350	350
E	mm	100	100	100	100	100

3.10 Positioning

3.10.1 Preliminary Warnings

⚠ Check that:

- the surface supports the weight of the appliance
- the surface does not affect piping or power lines
- the functionality of load-bearing elements is not compromised

3.10.2 Positioning the unit

The unit can be installed in two different ways:

- Horizontal ceiling installation
- Vertical wall installation

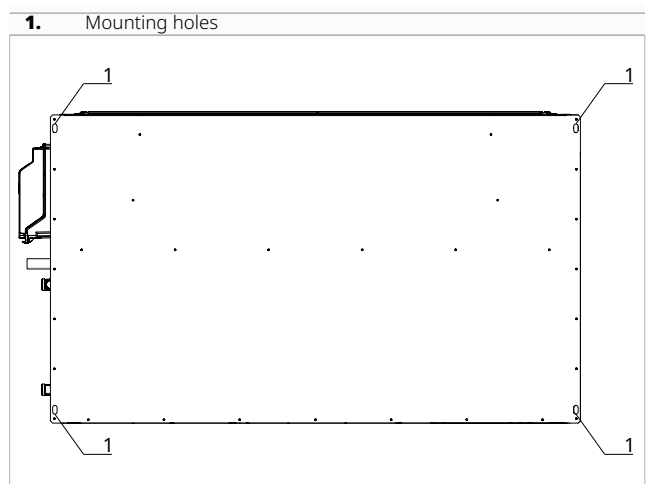

⚠ Use the 4 mounting holes on the upper side of the unit.

Horizontal ceiling installation

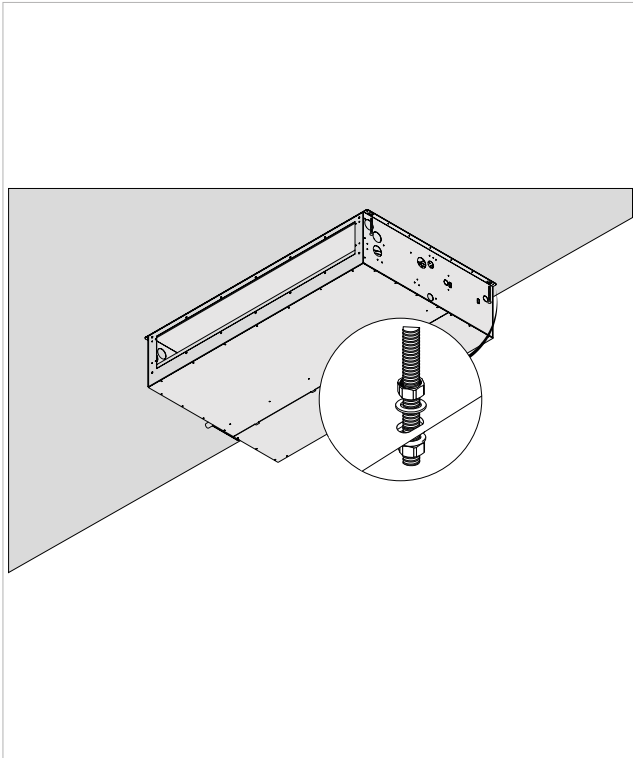

- ⚠ Check the correct orientation of the unit.
- mark the position of the fixing holes
- use fixing systems appropriate for the type of supporting surface and the weight of the unit
- secure the unit to the fixing system

Check that:

- it is levelled
- the minimum installation distances are respected

Vertical wall installation

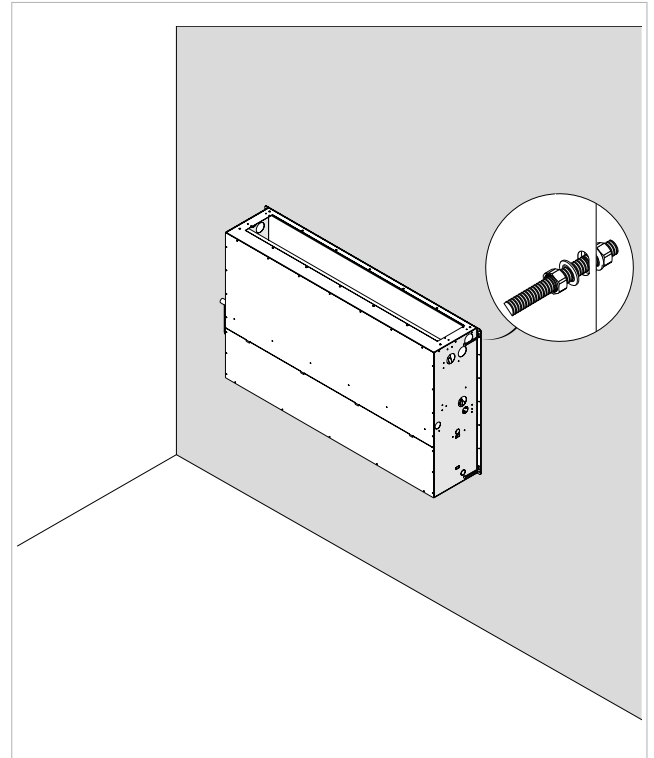

- ⚠ Check the correct orientation of the unit.
- mark the position of the fixing holes
- use fixing systems appropriate for the type of supporting surface and the weight of the unit
- secure the unit to the fixing system

Check that:

- it is levelled
- the minimum installation distances are respected

3.11 Hydraulic connections

3.11.1 Chemical and physical characteristics of water

- ⚠ Incompatible chemical and physical characteristics could compromise the integrity of the hydraulic components of the unit.
- ⚠ Check the characteristics of the water

DESCRIPTION	LIMIT VALUE
Hardness	< 10 °F
PH value	7,5 / 9
Oxygen	< 1 mg / L
Conductivity	< 500 uS / cm
Iron	< 2 mg / L
Manganese	< 1 mg / L
Nitrate	< 70 mg / L
Sulphate	< 70 mg / L
Chlorine compounds	< 300 mg / L
Free radical Carbon Dioxide	< 10 mg / L
Ammonium	< 20 mg / L

3.11.2 Position and dimensions

Horizontal installation

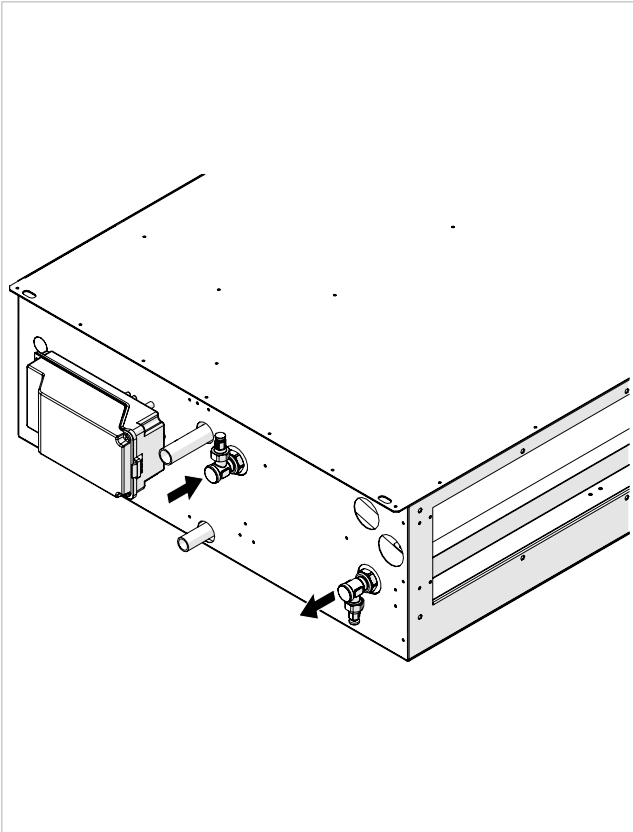

Vertical installation

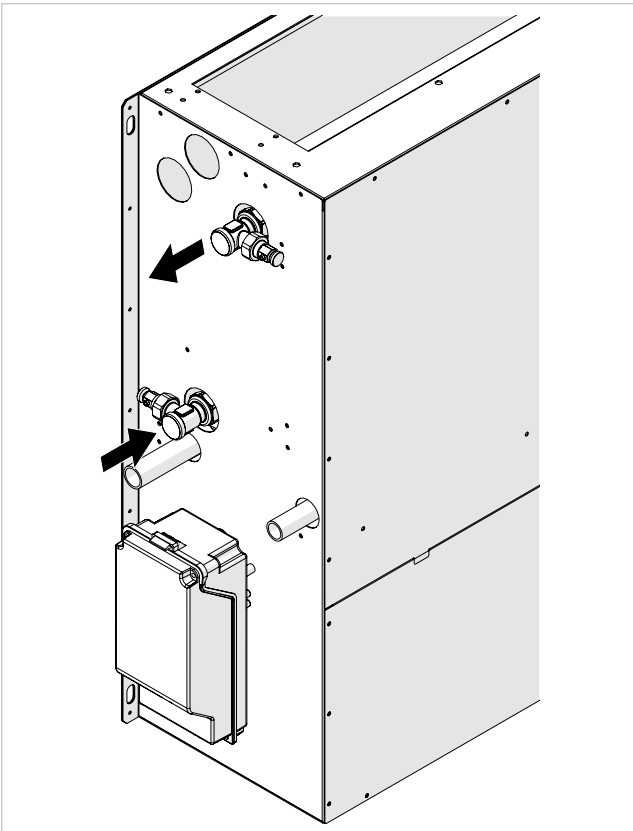

3.11.3 System connection

To make the connections:

- position the hydraulic lines
- use the 'key against key' method
- tighten the connections
- check for any leaks
- insulate the connections with insulation material

⚠ The hydraulic lines and joints must be thermally insulated.

⚠ Avoid partial insulation of the pipes.

⚠ Do not overtighten the connections to avoid damaging the insulation.

⚠ Carefully check the insulation seals to prevent condensation formation and dripping.

3.11.4 Connection with 2-way valve

In case of choosing the 2-way valve option:

- electrical connections are required

- connect to the lower outlet

A	Electrical cable entry hole
B	Connection for water inlet pipe
C	Thermoelectric motor

D	Connection for water outlet pipe
E	Machine body

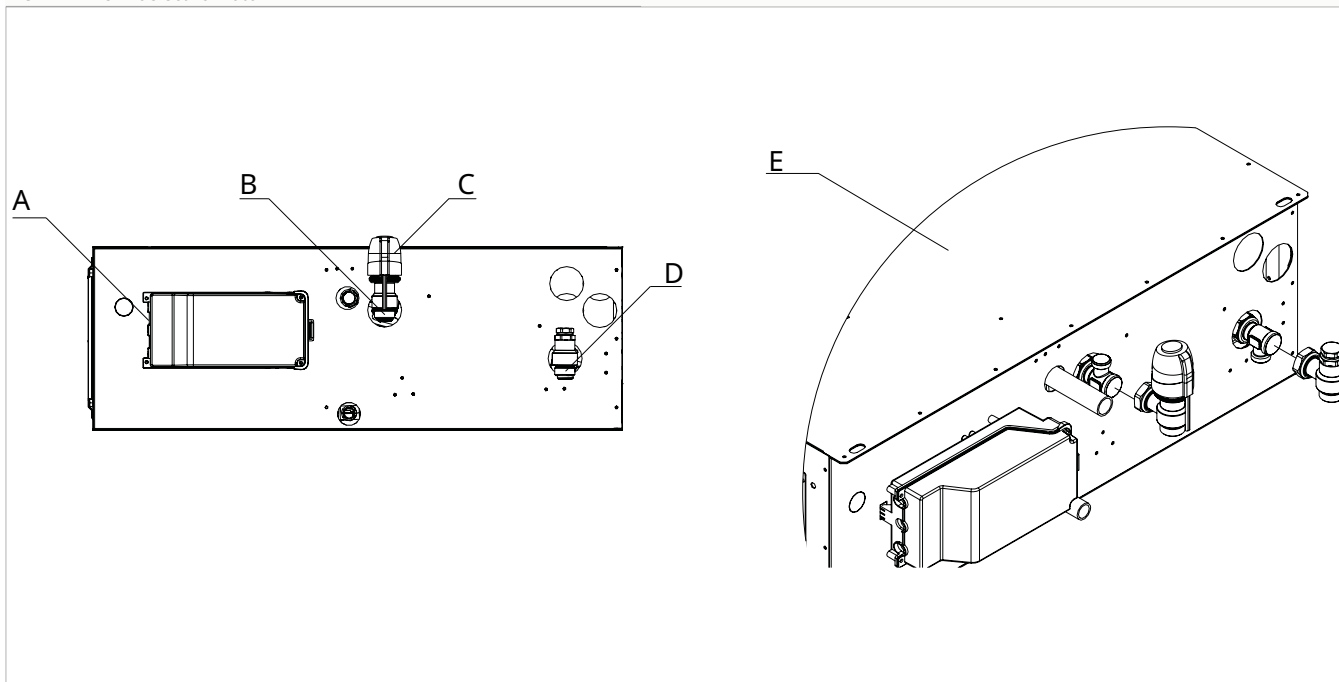

3.11.5 Connection with 3-way valve

In case of choosing the 3-way valve option:

- electrical connections are required

- connect to the lower outlet

A	Electrical cable entry hole
B	Connection for water inlet pipe
C	Thermoelectric motor

D	Connection for water outlet pipe
E	Machine body

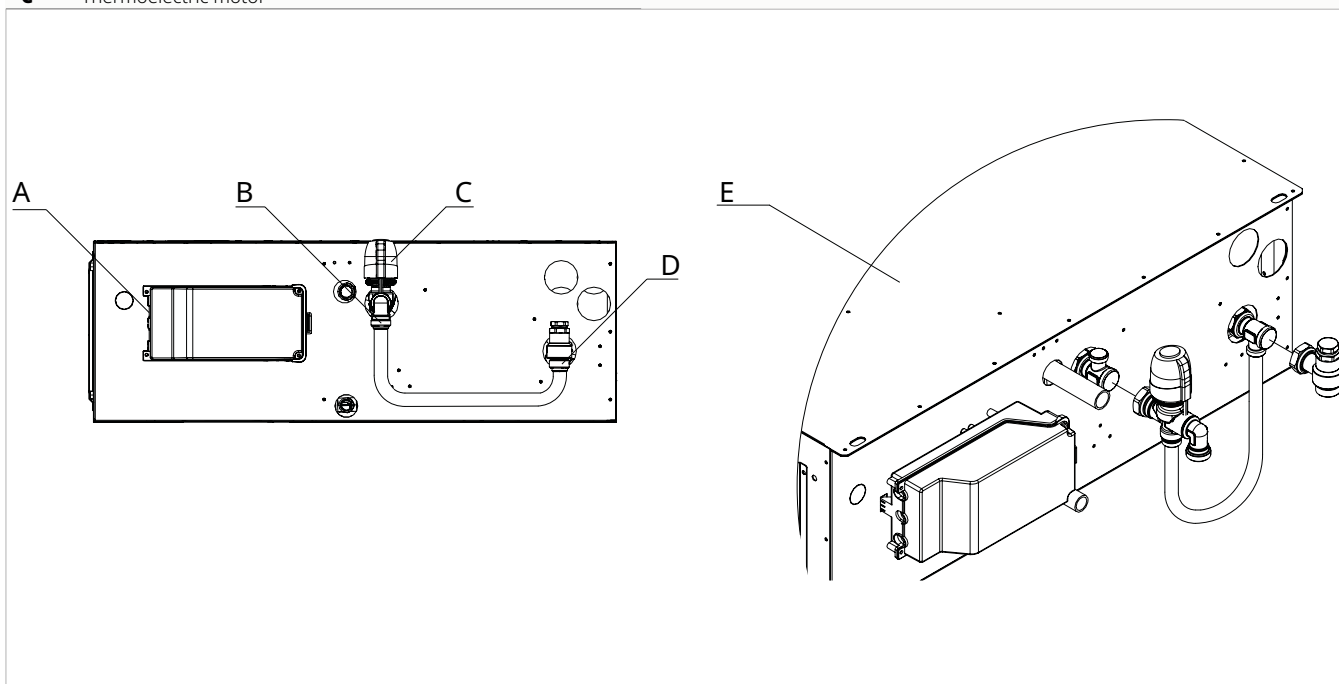

3.12 Condensate drain connection

3.12.1 Preliminary Warnings

- ⚠ This appliance is equipped with trays for collecting the condensate that is produced during operation. Condensate must be routed to a suitable place for drainage.
- ⚠ The appliance is equipped with two condensate drainage connections. One of the two must be used depending on the chosen configuration.
- ⚠ If the drainage line runs into a container (tank or other) it must be ensured that the container itself is hermetically sealed and most importantly it must be ensured that the drainage pipe is not immersed in water.
- ⚠ The hole for the condensate pipe must always have an outwards slope.
- ⚠ When connecting the condensate drain, take care not to crush the rubber pipe.

3.12.2 Attachment position

The unit has two condensate discharge connections. The size and position of the condensate drain attachments are shown below.

Horizontal installation

1. Horizontal condensate drain installation

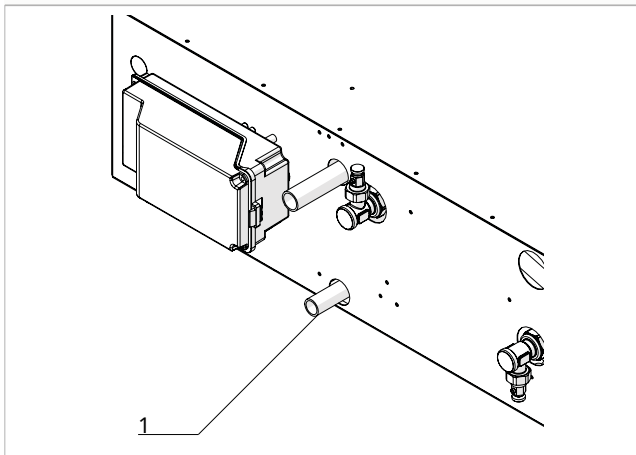

Vertical installation

1. Vertical condensate drain installation

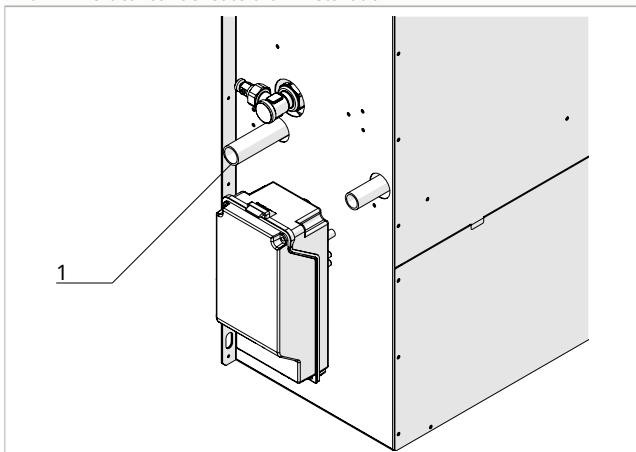

3.12.3 Connections

1. Condensate drain connection
2. Condensate drain pipe
3. Hose clamp

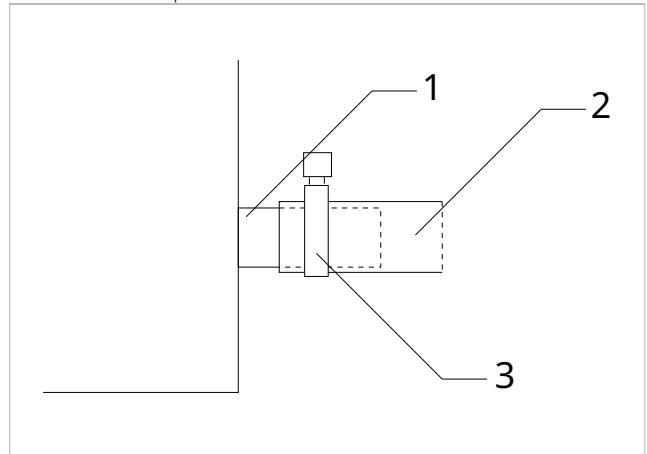

1. Unit

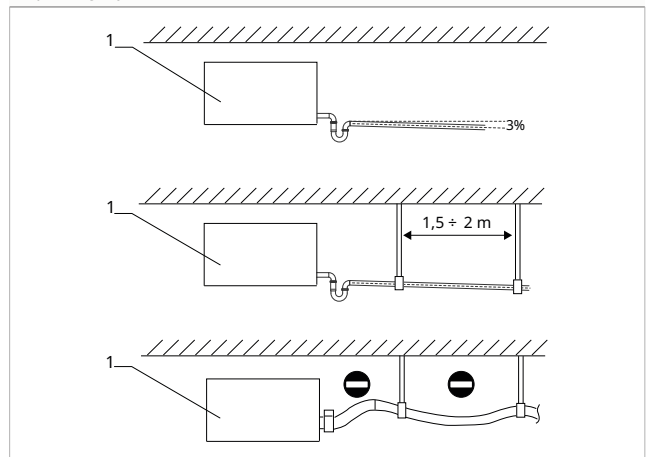

- | | |
|----|--------|
| HT | 100 mm |
| H1 | 50 mm |
| H2 | 50 mm |

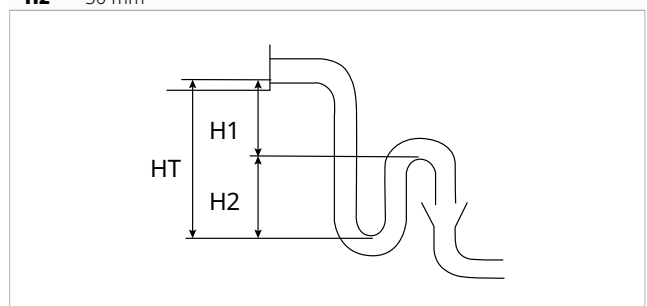

Depending on the chosen unit orientation:

- connect the drainage pipe to the connection provided on the unit
- install a siphon on the condensate drainage pipe near the unit
- direct the condensate drain pipe to a suitable place for draining

- maintain a minimum slope of 3% towards the drain location
- insulate junction points

⚠ It is mandatory to install an adequate siphon on the condensate drainage pipe to prevent the negative pressure generated by the fans from obstructing the proper flow of condensate, which could lead to spillage inside the premises.

⚠ The drainage system must include a suitable siphon to prevent unwanted air from entering the vacuum system. The siphon also prevents the entry of odours or insects.

⚠ The siphon must be fitted with a plug at the bottom or must in any case permit quick dismantling for cleaning.

⚠ Use plastic drainage pipes.

⚠ Avoid metal pipes.

⚠ Make sure all joints are sealed to prevent leakage of water.

⚠ Condensate drain pipes must be insulated for both indoor and outdoor sections to avoid condensation on the surface and/or frosting problems. The insulation must be inserted all the way to the condensate drain pipe connection on the unit.

3.13 System charging

To charge the system:

- open the relief valves on the devices
- open all the shut-off devices of the system
- slowly open the filling valve

When water starts coming out of the relief valves:

- close the relief valves
 - proceed with the filling
 - check that you have reached the nominal pressure specified for the system
 - close the filling valve
 - check the hydraulic tightness of the joints
- ⚠** It is advisable to repeat the operation after the appliance has been running for a few hours.
- ⚠** Periodically check the system pressure.

1. Air relief

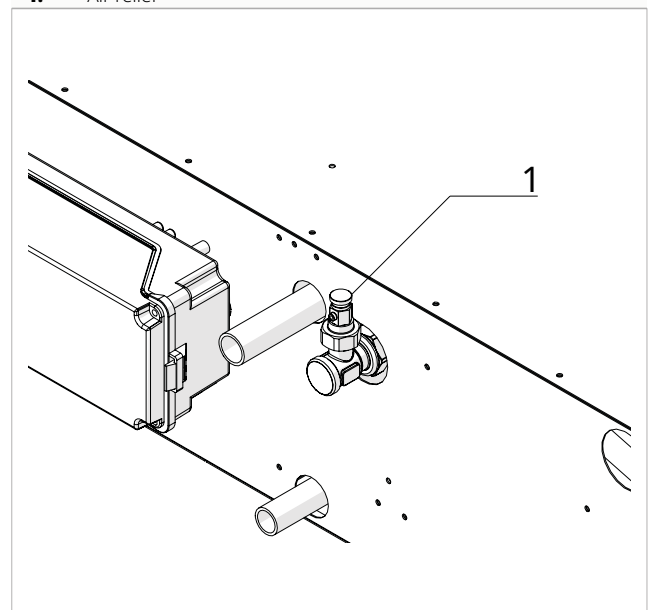

3.14 Aeraulic connections

3.14.1 Preliminary Warnings

- ⚠** The sizing of ducting and supply and extract grids must be carried out by a professionally qualified person.
- ⚠** To prevent the transmission of any vibrations of the machine into the room, an anti-vibration joint should be placed between the fan outlets and the ducts.
- ⚠** The connecting pipes must be of a suitable diameter and supported so that their weight does not put a strain on the appliance.

3.14.2 Connections

Horizontal installation

- A** Extracted air rear orientation
- B** Extracted air lower orientation

- C** Air supply

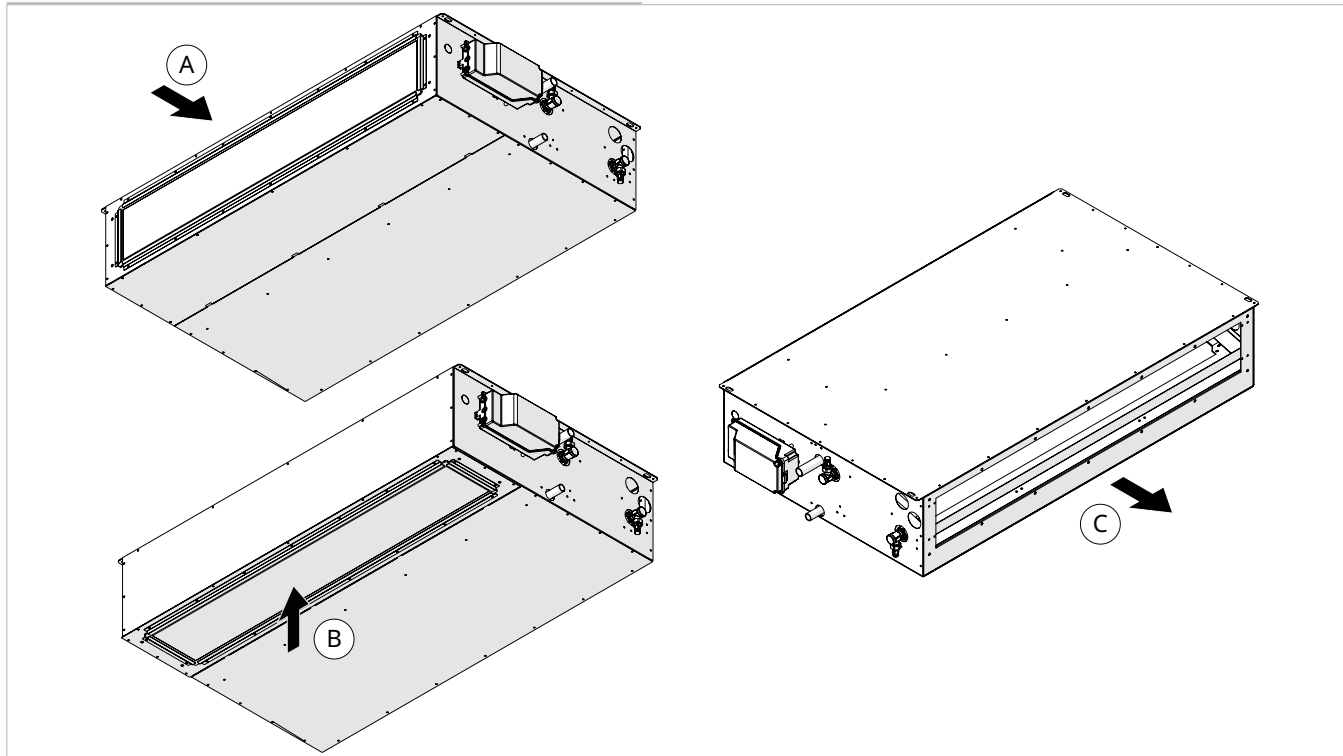

Vertical installation

- A** Extracted air lower orientation
- B** Extracted air front orientation

- C** Air supply

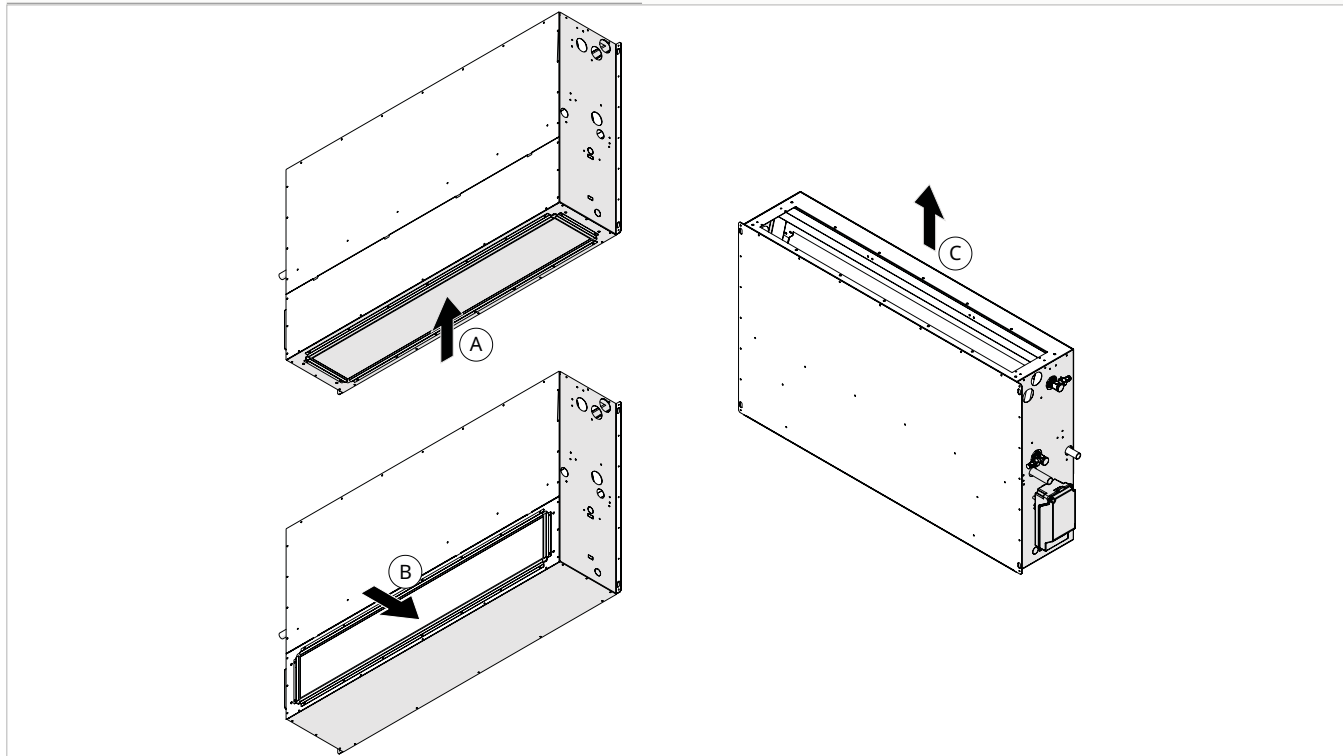

Extracted air dimensions

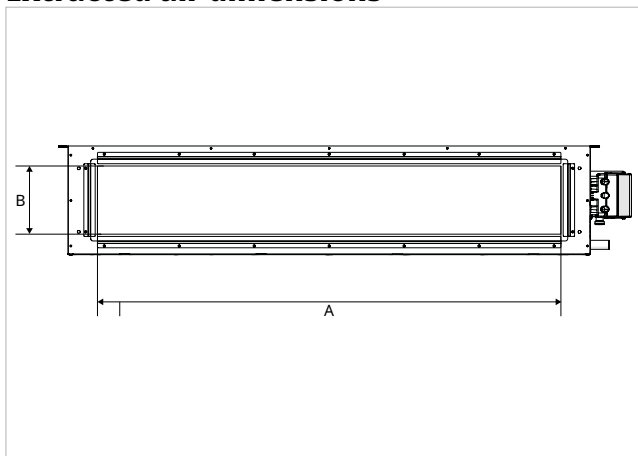

Air supply dimensions

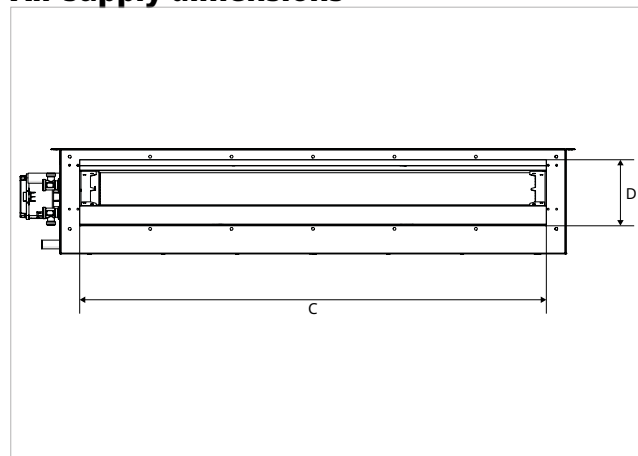

Models	u.m.	40	60	80	100	120
Extracted air dimensions						
A	mm	510	710	910	1110	1370
B	mm	150	150	150	150	150
Air supply dimensions						
C	mm	460	660	860	1060	1320
D	mm	120	120	120	120	120

3.14.3 Extracted air configurations

- A factory configuration
- B configuration modifiable on site

Horizontal installation

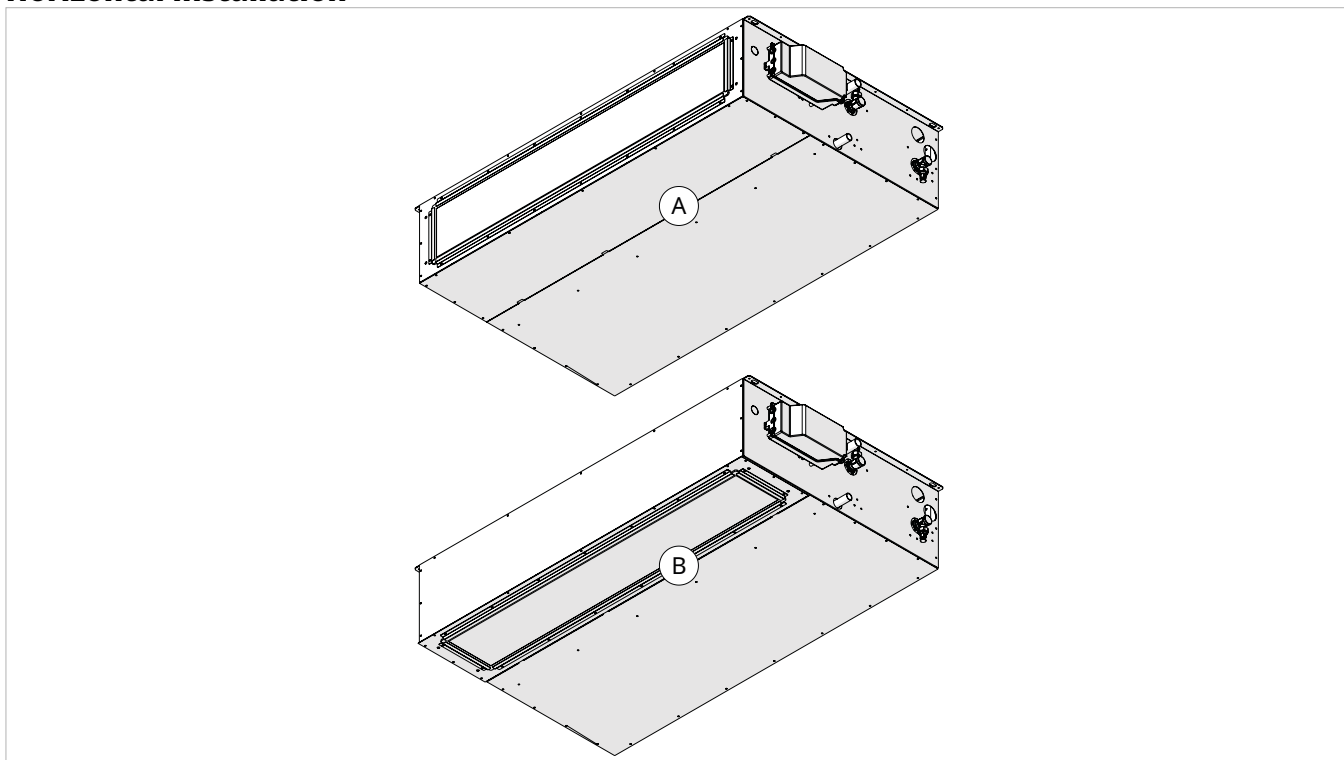

Vertical installation

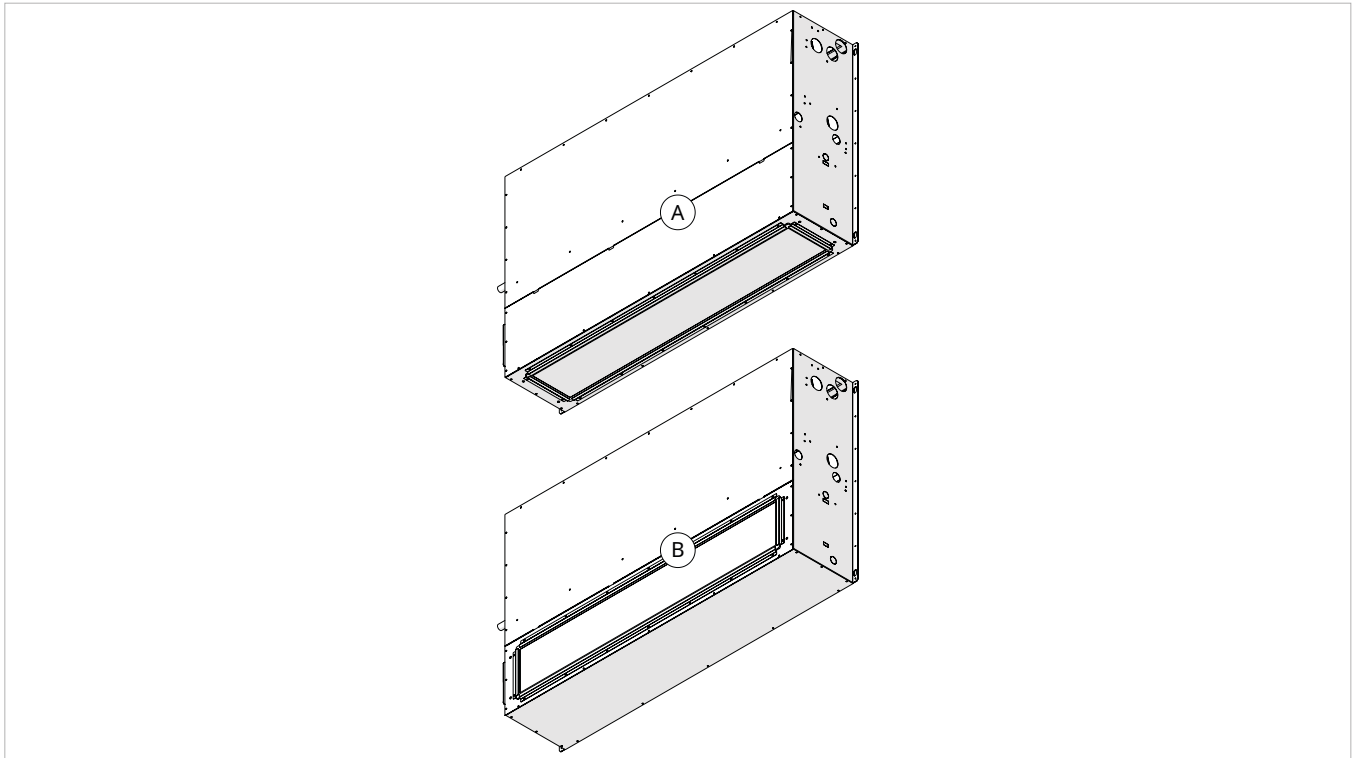

Modification of the extracted air configuration

To modify the configuration of the extracted air:

1. Blind panel

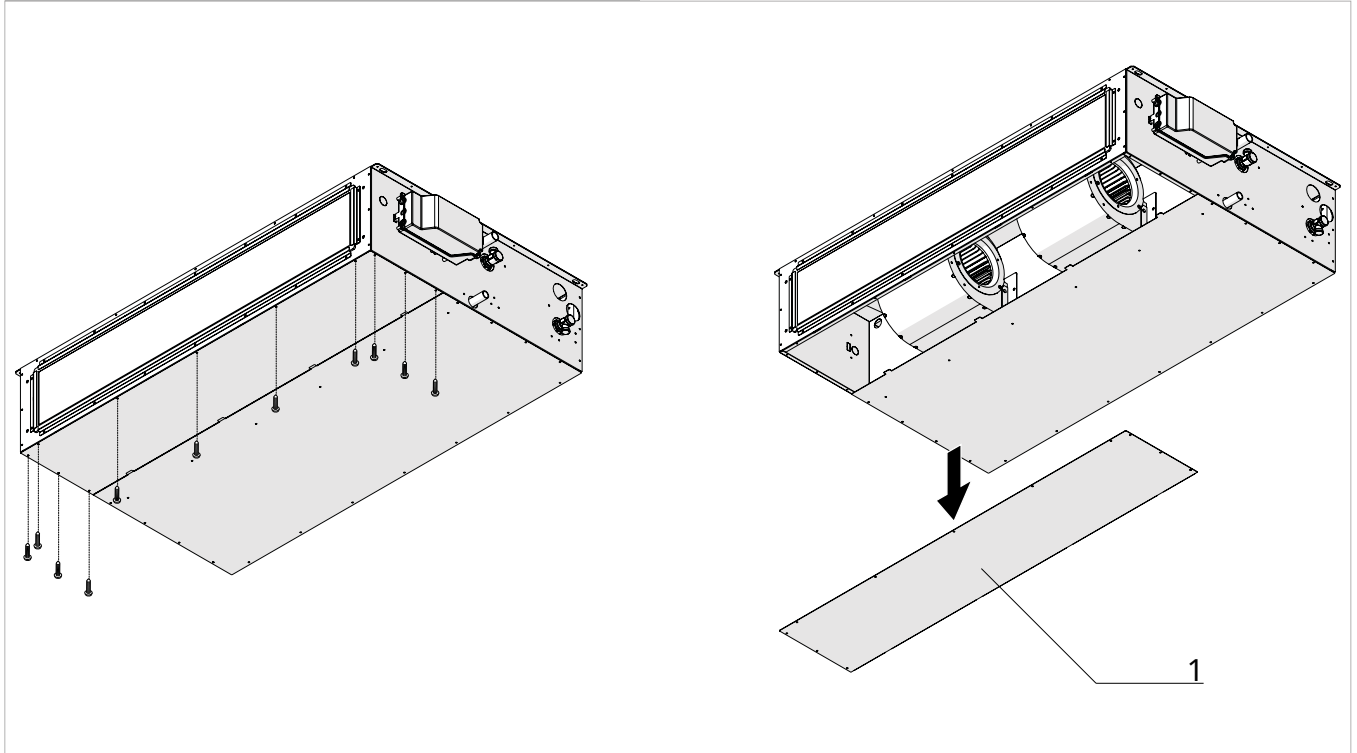

– remove the screws from the blind panel

– remove the blind panel

1. Extracted air panel

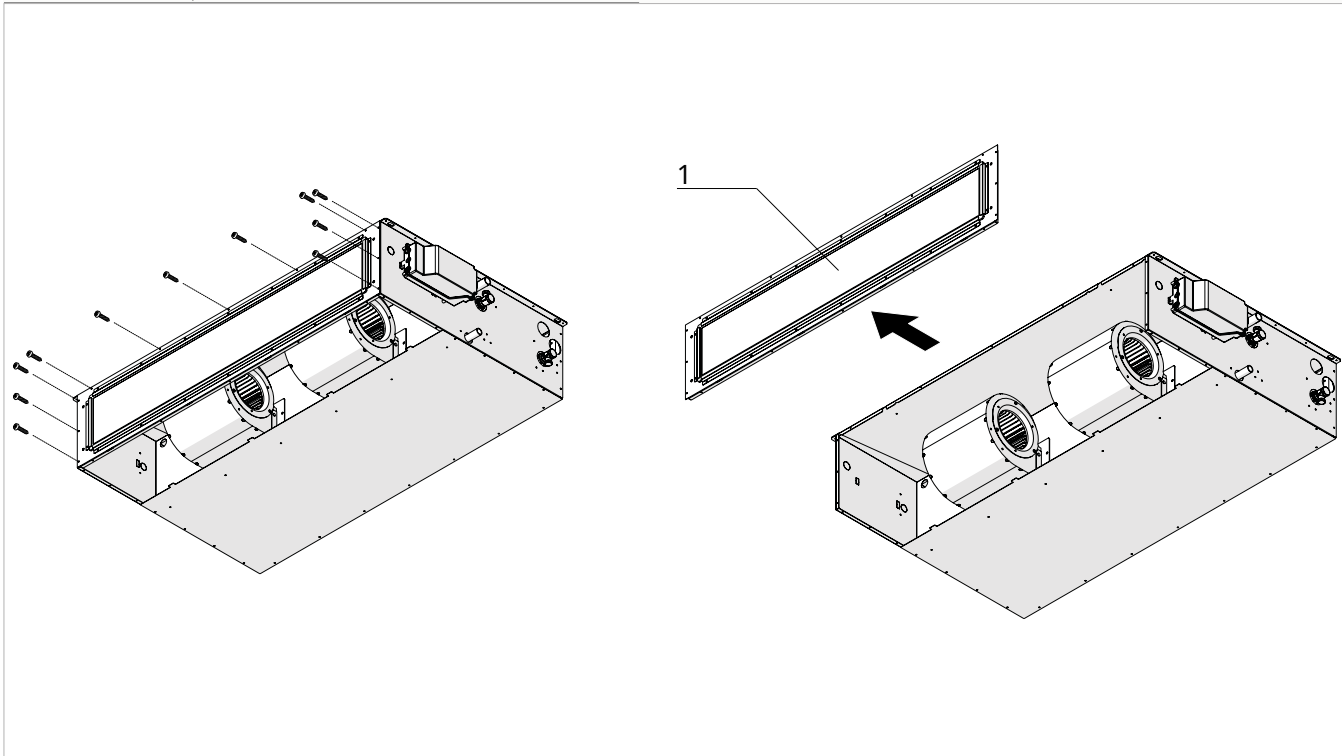

- remove the screws from the extracted air panel

- remove the extracted air panel

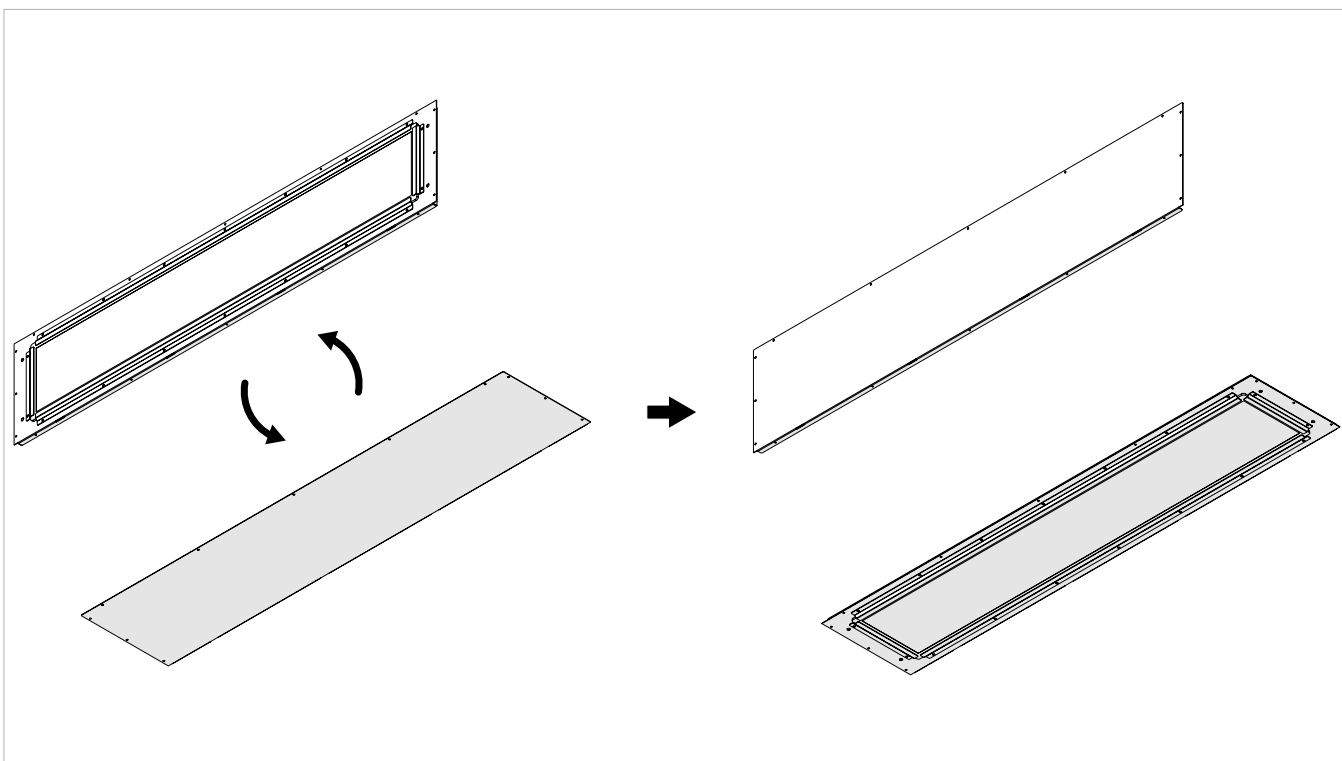

- switch the position of the blind panel with the extracted air panel

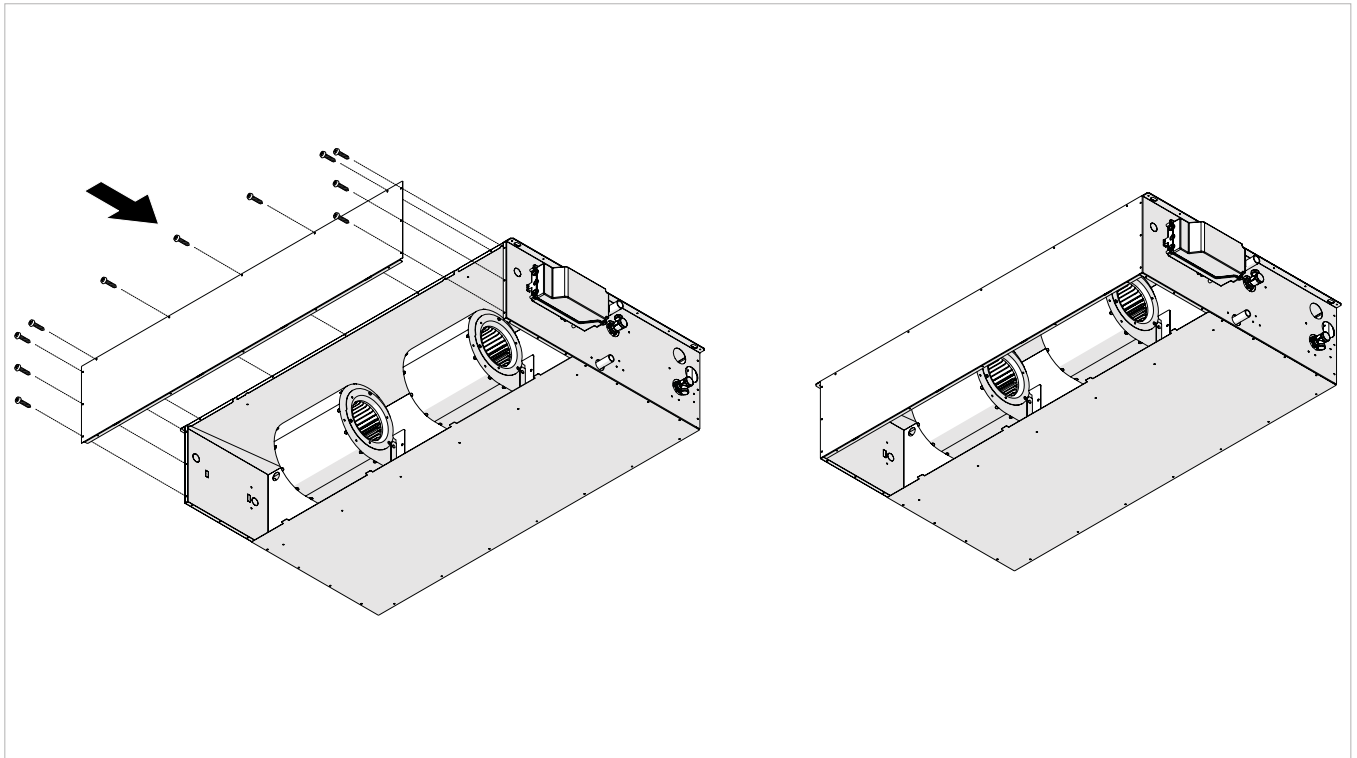

- secure the blind panel to the unit

- use the previously removed screws

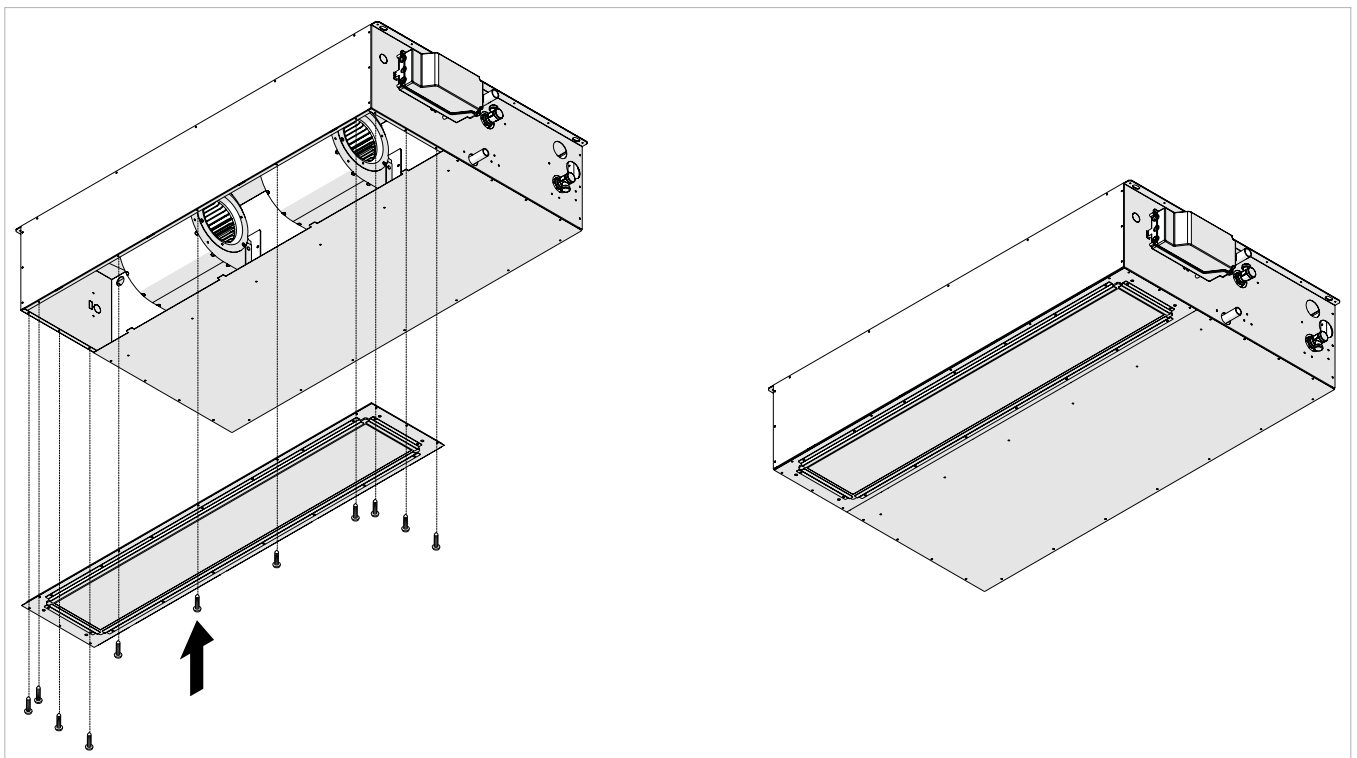

- secure the extracted air panel to the blind panel and to the unit

- use the previously removed screws

3.15 Electrical connections

The appliance leaves the factory fully wired and only requires connection to the power supply, control and any accessories.

3.15.1 Preliminary Warnings

- ⚠ All operations of an electrical nature must be carried out by qualified personnel having the necessary legal requirements, trained and informed about the risks related to such operations.
- ⚠ All connections must be made in accordance with the relevant regulations in force in the country of installation.
- ⚠ Before carrying out any work, make sure that the power supply is switched off.
- ⚠ The unit should only be powered after the plumbing and electrical work has been completed.
- ⚠ References:
 - for electrical connections please refer to the wiring diagrams in this manual, especially for the part concerning the power terminal board
 - for the supply voltage, please refer to the nameplate on the appliance
- ⚠ Check that:
 - the mains characteristics are adequate for the power consumption of the appliance, also taking into account any other machinery in parallel operation
 - the power supply voltage and frequency correspond to those specified on the nameplate on the appliance
 - the cables are suitable for the type of laying in accordance with the IEC standards in force
 - the cable terminals are provided with ferrule terminals, of a cross-section proportionate to the connecting cables, before inserting them into the terminal board
 - the power supply is adequately protected against overloads and/or short circuits
- ⚠ It is mandatory:
 - to connect the appliance to an effective grounding system
 - for units with three-phase power supply, check the correct phase connection
 - install a dedicated disconnecter equipped with delayed fuses or an all-pole magnetothermic circuit breaker complying with IEC-EN standards, suitable for the absorption of the appliance, with differential relay with a maximum setting equal to that specified by the individual electrical regulations
- ⚠ Ensure that a connection to earth is made. Do not ground the appliance to distribution pipes, surge arresters or the ground of the telephone system. If not performed correctly, grounding can cause an electric shock. Momentary high voltage surges caused by lightning or other causes could damage the ventilation unit.
- ⚠ A ground dispersion breaker is recommended. Failure to install this device could result in an electric shock.

- ⚠ Electrical connections must be carried out in accordance with the instructions in the manual and the standards or practices governing the connection of electrical appliances at national level. Insufficient capacity or incomplete electrical connections could lead to electric shock or fire.
- ⚠ The power supply line must be adequately dimensioned to avoid voltage drops or overheating of cables or other devices placed on the line.
- ⚠ Use a dedicated power supply circuit. Never use a power supply to which another appliance is also connected due to risk of overheating, electric shock or fire.
- ⚠ For the electrical connection, use a cable of sufficient length to cover the entire distance without any connection. Do not use extension cables. Do not apply other loads on the power supply.
- ⚠ After connecting the interconnection and power supply cables, ensure that the cables are arranged so that they do not exert excessive forces on the covers or electrical panels. Install the covers on the cables. Incomplete connections of the covers can lead to overheating of the terminals, electric shock or fire.
- ⚠ Any replacement of the power cable must only be carried out by qualified personnel and in accordance with current national regulations.
- ⚠ The manufacturer is not liable for any damage caused by the lack of earthing or failure to comply with the specifications in the respective diagrams.
- ⚠ The appliance is equipped with a noise filter as required by current regulations. Use selective residual current circuit breakers to compensate for the micro leakage to earth of this device.
- ⊖ Using gas and water pipes to ground the appliance is prohibited.

3.15.2 Power line dimensioning

Use the tables below for the sizing of the power supply line and its protection device.

These are not average draw or transient peaks, but values to be considered for the correct sizing of the plant and the request of the contractual power (excluding loads due to the normal operation of the building).

- ⚠ Maximum power is reached only in exceptional cases. Therefore, the indicated trip current is suggested to guarantee a balance between machine absorption and incidence in the general system.
- ⚠ The indicated minimum cable cross-section area must be verified according to the actual conditions of the installation: length of the cable, characteristics of the electrical supply, etc.
- ⚠ For units equipped with electrical heating elements, the draw values of the units must be added to those of the heating elements shown in the following tables.

3.15.3 Access to the electrical panel

- ⚠ Access to the electrical panel is only permitted to qualified personnel.

⚠ Before carrying out any work, ensure that the power supply is switched off.

1. Electrical panel closing panel

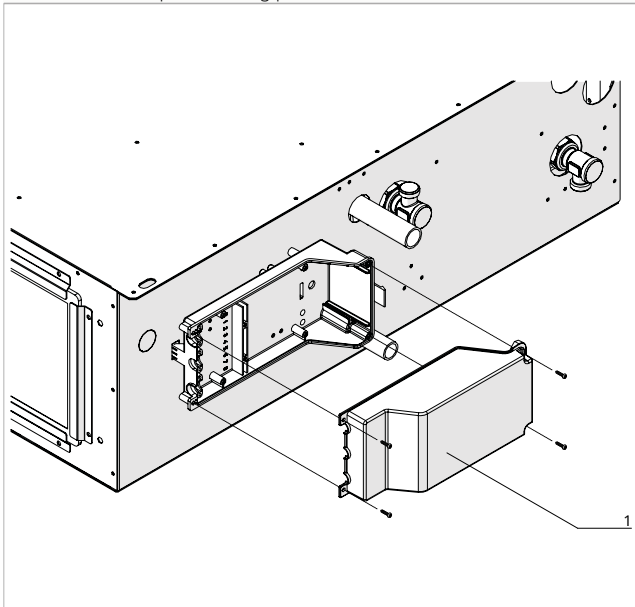

To access the connections:

- remove the fixing screws
- remove the electrical panel closing panel

3.15.4 Connections

Before connecting the unit to the mains power supply, make sure that the disconnecter is open. The power supply of the single-phase unit must be connected to the appropriate terminals, subjected to the action of the isolating switch.

⚠ Use properly sized cables to avoid voltage drops or overheating.

3.15.5 Connection diagram

- | | |
|--------------------------|--------------------------------------|
| 1. 230/1/50 power supply | 4. FNC |
| 2. Disconnecter | 5. Remote control |
| 3. Power cable | 6. Control panel communication cable |

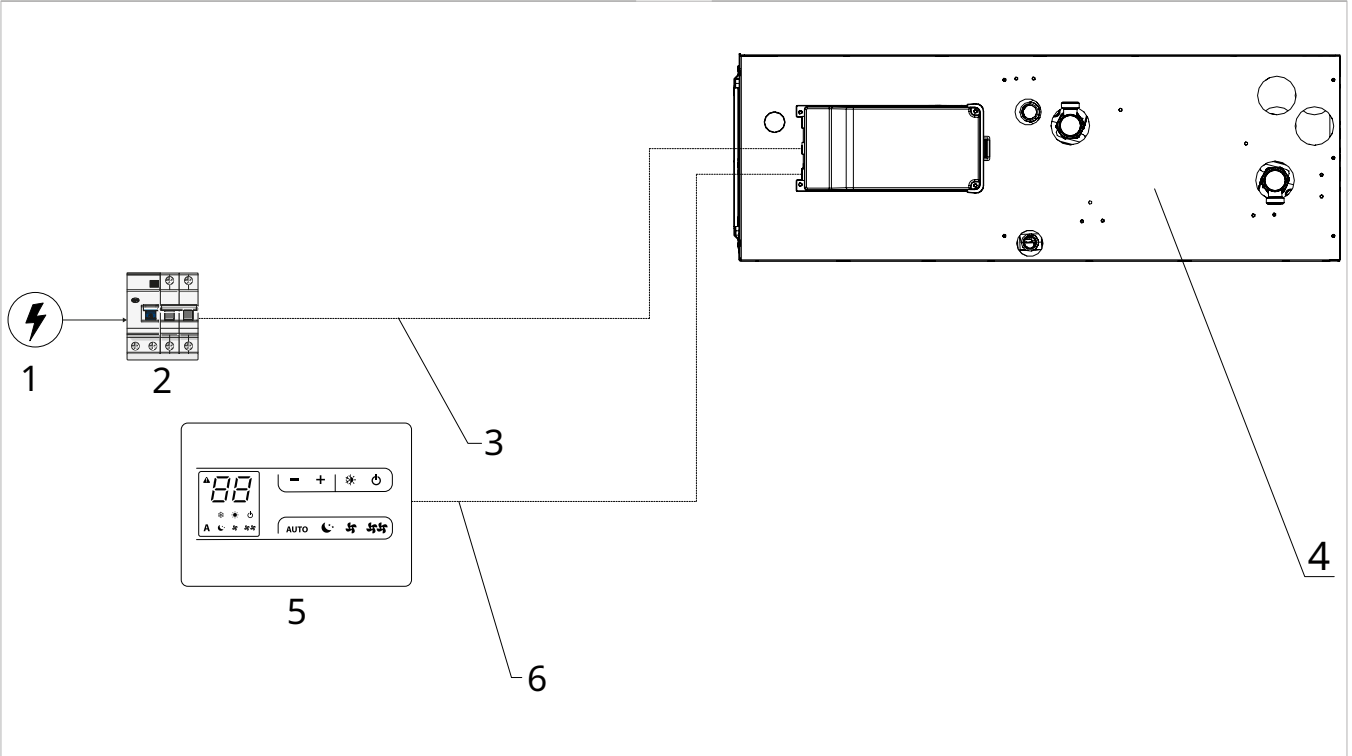

3.15.6 On-board electrical panel

Connection terminal board

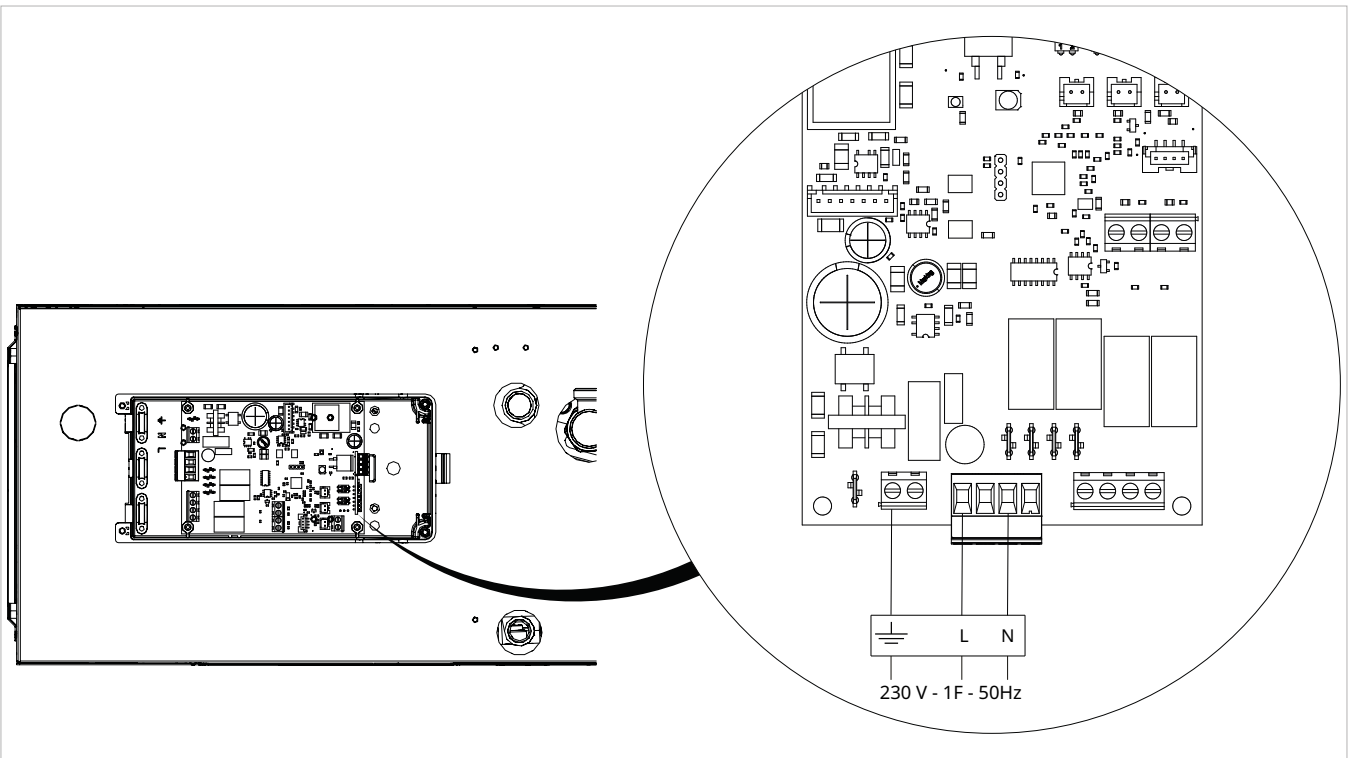

REMOTE CONTROL

4.1 Installation

4.1.1 Description

The control panel is an electronic controller with humidity and air quality sensors inside, with the possibility of control over several devices equipped with the same circuit board. It is equipped with a humidity and air quality sensor.

⚠ The temperature probe can be remote-controlled in one of the connected units.

4.1.2 Mounting

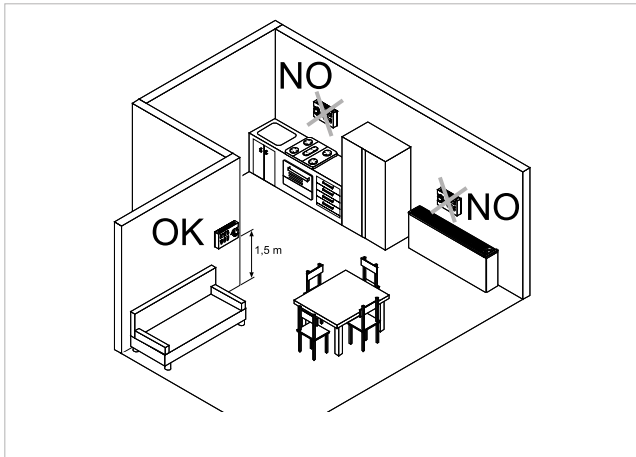

The control panel must be installed:

- on the outside walls
- at a height of approx. 1.5 m above the floor
- away from doors and windows
- away from heat sources such as radiators, fan coils, cookers, direct sunlight

⚠ The control panel is supplied in the package already assembled.

A Notches

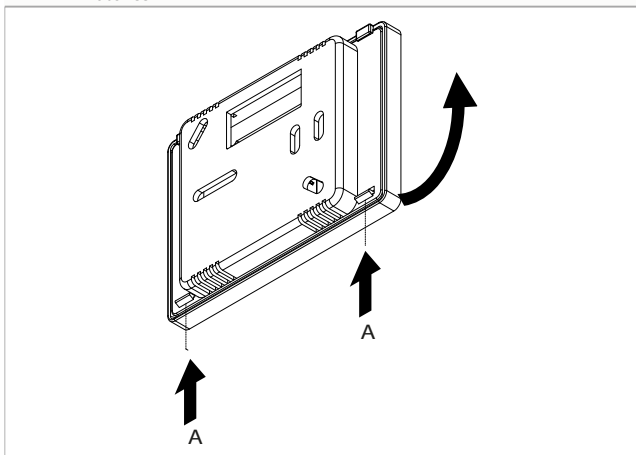

Before mounting on the wall:

- release the fastening notches on the rear side of the control panel
- separate the base from the control panel
- use the base as a template to mark out the fixing points

- A** Control base
- B** Holes for fixing to the wall
- C** Screws
- D** Hole for the passage of electrical connections

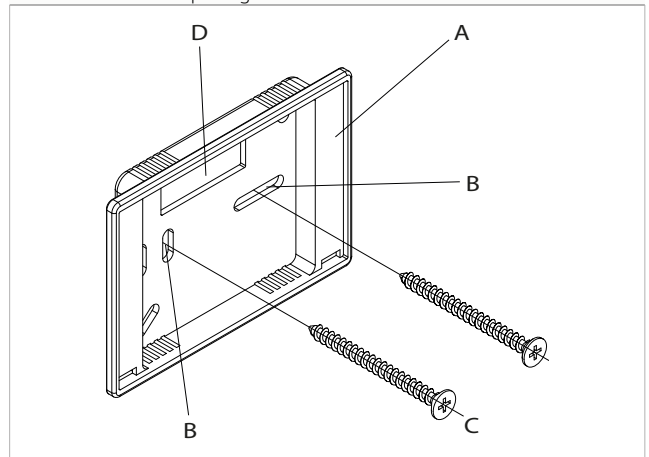

For wall mounting of the control panel:

- drill holes in the wall
- pass the electrical cables through the prepared hole
- fix the base of the control unit to the wall using suitable screws and dowels
- make electrical connections
- close the control panel

⚠ Take care not to crush the wires when closing the control panel.

4.2 Electrical connections

4.2.1 Connection diagram

Unit I version

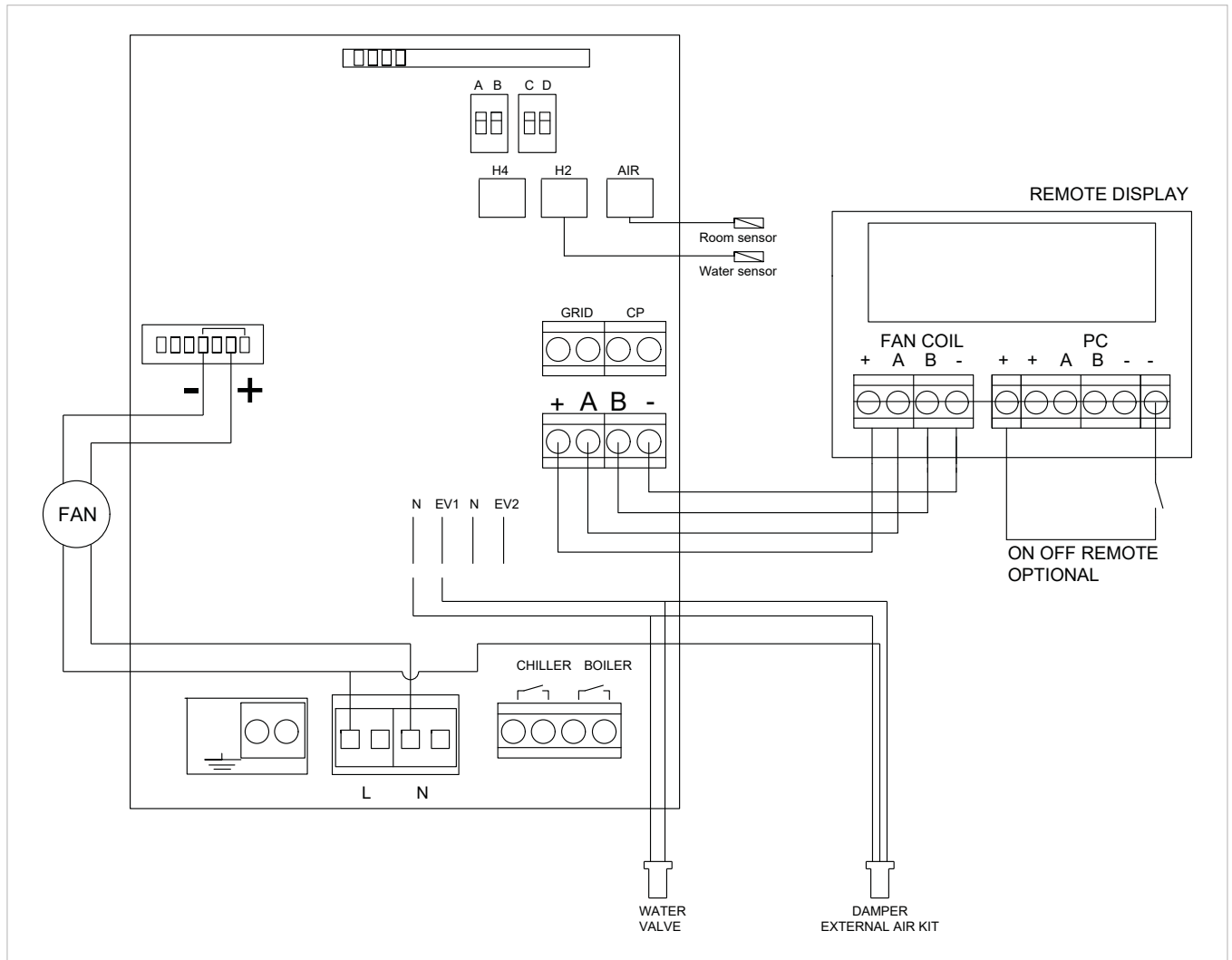

Connections to be made by the customer

Grid	Window contact	Contact closed / Unit on
CP	Presence contact	Contact closed / Unit off
Chiller	Generator consent / Summer pump	Free contact (cooling request activation)
Boiler	Generator consent / Winter pump	Free contact (heating request activation)
Water valve (N-EV1)	Water valve / post coil	Voltage contact (220 v)
Remote display	Remote control (4 wires)	
Remote On - Off (on display)	On - Off remote contact on remote display	Contact closed / Unit off
External air kit damper	External air kit damper	Voltage contact 220V

Unit S version

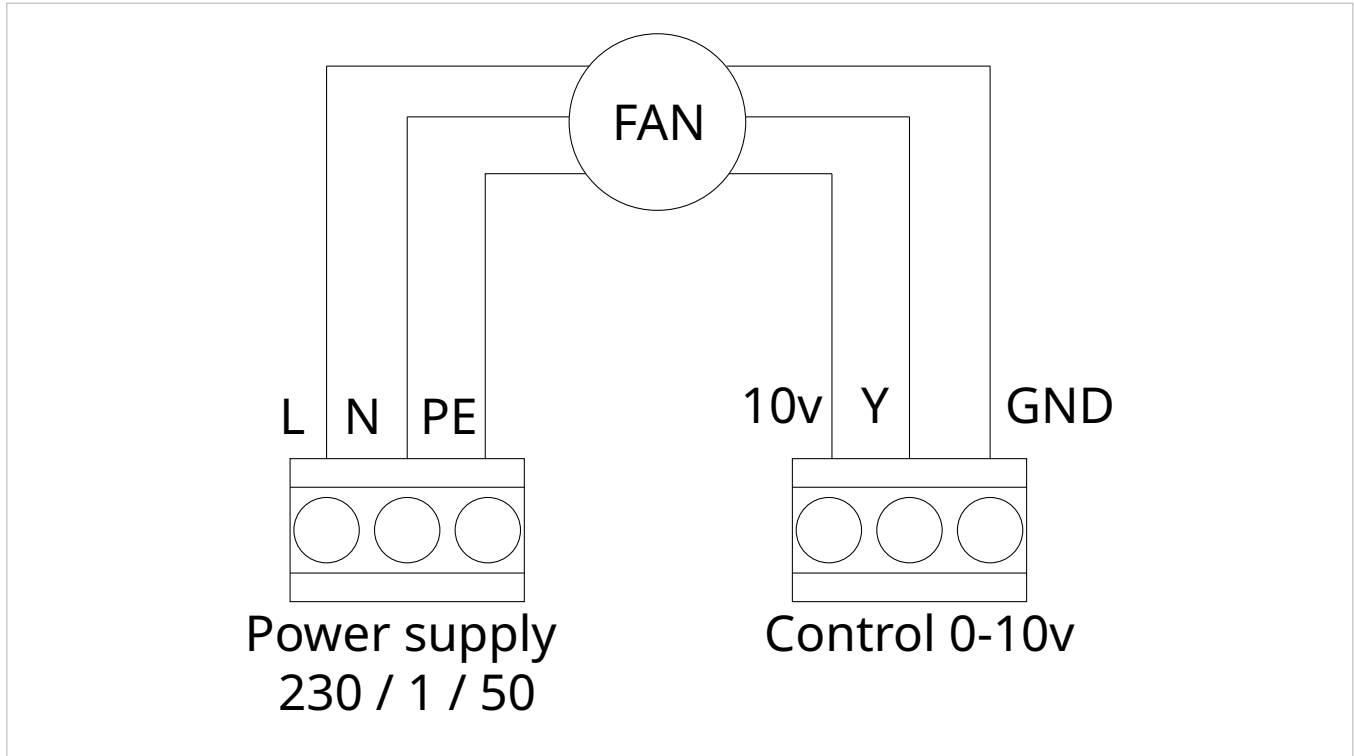

Connections to be made by the customer		
L - N - PE	Power supply 230 / 1 / 50	Check power
10v	Voltage reference signal	Voltage supplied by the motor (I max = 20 mA)
Y	0-10V DC signal to the motor	
Gnd	Reference signal	

⚠ Valve and external air kit damper must be controlled by the customer's adjustment.

with a cable lug with plastic collar the maximum cross-section is reduced to 0.75 mm².

4.2.2 Terminal board position

A terminal board

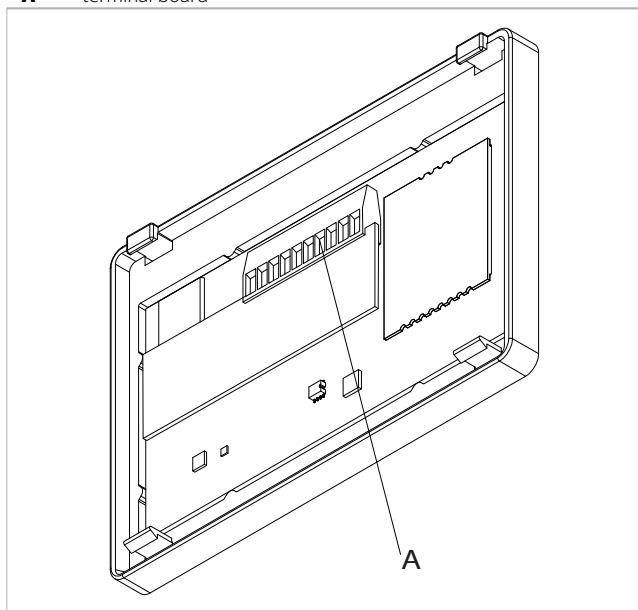

The terminals allow the connection of rigid or flexible cables with cross-sections of 0.2 to 1 mm². For cables equipped

4.2.3 Connection to circuit board

For the connection:

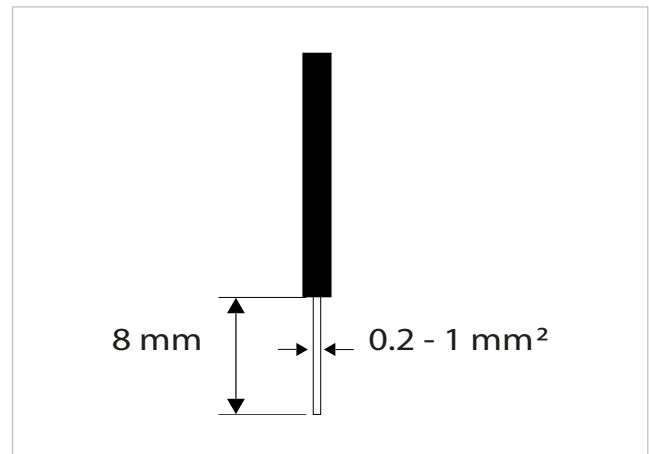

- remove a portion of the insulation from the cable end
- insert the cable into the terminal
- screw tightly
- check for correct attachment by lightly pulling on the cable

- ⚠ The cable must be shielded twisted 4 x 0.75 mm², maximum length 50 m.

4.2.4 On - Off remote connection

Through this contact it is possible to connect an external device which inhibits the operation of the appliance, such as:

- remote on/off (on display)

Operation

When the contact connected to the PC input is closed, all units are switched off.

When a button is pressed on the display, the symbol  flashes

- ⊖ It is forbidden to connect the PC input in parallel with other electronic boards. In this case, use separate contacts.

4.2.5 RS485 serial connection

The control panel can be connected via an RS485 line to one or more units directly to the control board on the unit or via the remote displays.

For the connection:

- respect the indications "A" and "B"
- connect appliances in series

- ⚠ Use a shielded two-core cable suitable for serial RS485 connection with a minimum cross-section of 0.35 mm².
- ⚠ Keep the two-core cable separate from the power supply cables.
- ⚠ Route in such a way as to minimise the length of deviations.
- ⚠ Terminate the line with the 120 Ω resistor supplied.
- ⊖ "Star" (y) connections are prohibited.

4.3 Interface

4.3.1 Description

The control panel is an electronic controller with humidity and air quality sensors inside. It has the possibility of operating several units equipped with the same circuit board.

Features:

- temperature probe and humidity probe inside the control panel
- internal memory with data storage even in the event of abnormal shutdown or power failure
- ⚠ The room temperature probe provides frost protection even when the control panel is in stand-by mode.
- ⚠ The brightness of the control panel is reduced 20 seconds after the last action, the display only shows the room temperature. Pressing any button restores maximum brightness.
- ⚠ Refer to the User's Manual for operation on the control panel.

4.3.2 Display

A Display area

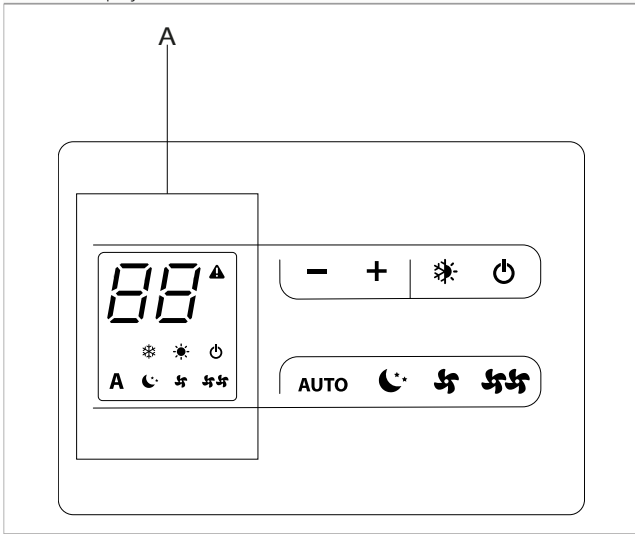

Status and alarms shown on the display.

- Alarm indication
Flashing with closed CP contact
Lit for alarm indication
- Summer mode active
- Winter mode active
- Unit in stand-by
- A** Auto function
- Minimum ventilation speed activated
- Rated ventilation speed activated
- Maximum ventilation speed activated

4.3.3 Keypad key functions

A Keypad area

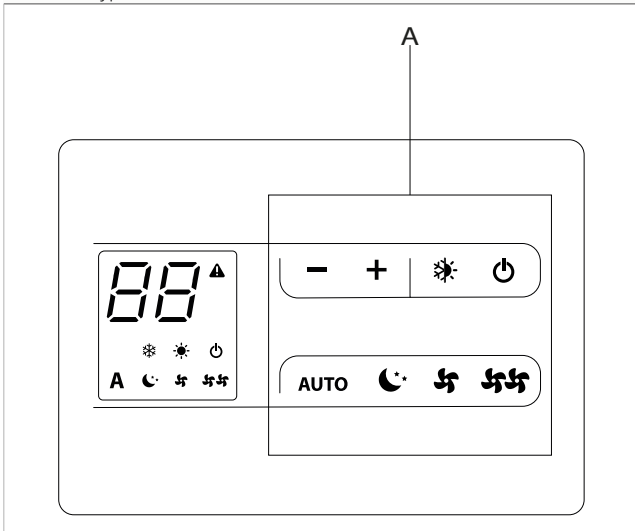

Related keys and functions

- Decreases the set temperature
- Increases the set temperature
- Allows you to change the operating mode between summer and winter
- Allows the control panel to be switched on or put into stand-by mode
- AUTO** Makes the ventilation speed adjustment completely automatic based on the ambient temperature
- Allows you to set the minimum ventilation speed
- Allows you to set the rated ventilation speed
- Allows you to set the maximum ventilation speed

4.3.4 General switch-on

Before switching on:

- Make sure that the control panel is connected to the power supply.
- If there is a main switch on the power supply line, switch the system on by pressing the switch.

To activate the device

- press and hold the button
- The symbol lights up

4.4 Warnings

4.4.1 Switching off for extended periods

In case of seasonal or long-term shutdown:

- deactivating the device
- set the system's main switch to off

⚠ The anti-freezing function is deactivated.

4.4.2 Error indication

⚠ **E1** Fault in the room temperature sensor located in the thermostat

⚠ **E2** Fault or connection of a double remote room sensor on one of the connected appliances

⚠ **E3** Temperature/humidity sensor not working

⚠ **E4** Air quality sensor not working

Error display

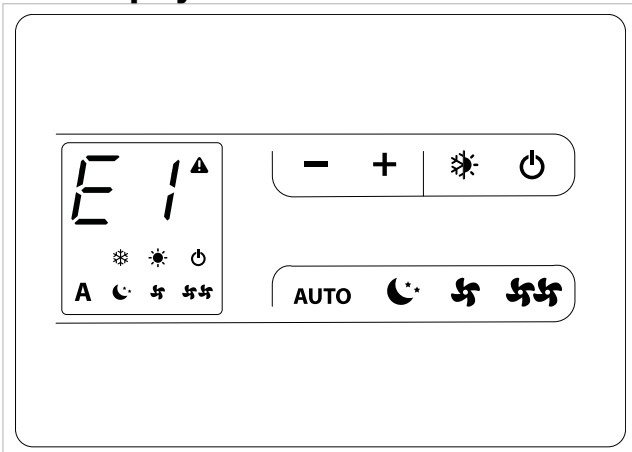

Filters alarm

- the symbol ⚠ flashes on the screen
- the filters have reached the operating time limit

To fix

- replace filters
- reset the panel

To replace filters

- refer to chapter 6.1.2 [p. 40](#)

To reset the panel

- press and hold the button  for 5 seconds

Filter alarm display

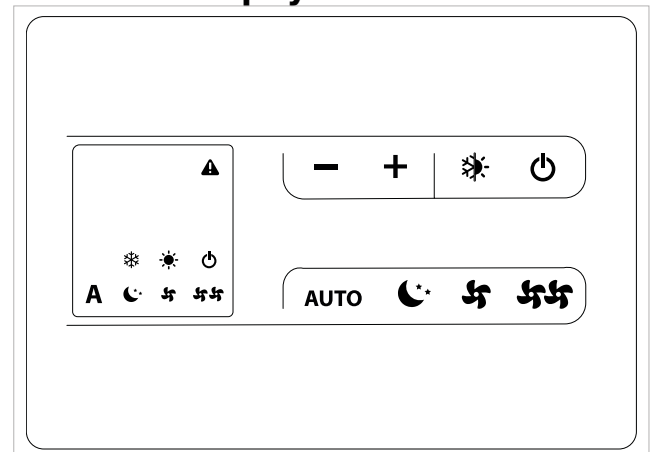

START-UP

5.1 Preliminary Warnings

⚠ **This section is dedicated to the Technical Service Centre. The specifications of the Technical Service Centre are described in chapter 1.1.3 p. 5.**

⚠ **Initial commissioning must be carried out by the Technical Service Centre.**

⚠ **For detailed information on accessories, refer to the relevant instruction sheets.**

See chapter 2.7 p. 11

⚠ The customer must be present when the appliance is tested and informed of the contents of the manual and procedures. After commissioning, the manual and the warranty certificate must be handed over to the customer.

⚠ Before start-up, all works (electrical, hydraulic and air-flow connections) must have been completed.

5.2 First start-up

5.2.1 Preliminary Checks

Before commissioning, check that:

Operational checks

- all safety conditions have been met
- the unit has been properly secured to the supporting surface or wall
- the minimum technical spaces have been observed

Airflows

- the airflow connections have been made according to the instructions in the manual
- all airflow connections are correctly secured
- the ducting is correctly supported
- the ducting does not have any bottlenecks
- the ducting is thermally insulated

Electrical checks

- the cross-section of the power supply cables is adequate for the absorption of the appliance and the length of the connection made
- grounding is correctly performed
- the electrical connections have been established correctly
- all control wires are connected and that all electrical connections are secure

5.2.2 Settings

Room temperature control

The room temperature control is defaultly carried out with the ambient air probe (AIR) positioned on the air intake. Alternatively, it is possible to use the temperature probe inside the control panel.

To set the probe inside the control panel:

- disconnect the AIR probe from the electronic board

5.2.3 Start-up

After all checks have been carried out, the unit can be put into operation.

To activate the appliance:

- refer to the user manual

⚠ Should the startup be impeded by the water temperature, to temporarily force it, remove the water probe from the board. This will deactivate the control, allowing immediate startup. Reconnect the probe as soon as possible to ensure proper unit functionality.

5.2.4 Checks with the machine switched on

After starting up, check that

Operational checks:

- verify the different modes of operation
- verify that the appliance stops and then restarts
- switch the appliance off and on again and check that it restarts correctly
- the appliance operates within the recommended operating conditions (see technical specifications table)
- check that the air flow rates are correct

Hydraulic Checks

- check for proper condensate drainage

Electrical Checks

- the current absorbed is less than the maximum indicated in the technical data table
- the supply voltage value is within the set limits and does not fall below the nominal value -10 % during operation

5.3 Plant delivery

Once all the checks and controls on the correct operation of the plant have been completed, the installer must explain the following to the user:

- the basic functional characteristics of the appliance
- the instructions for use
- the routine maintenance

5.4 Switching off for extended periods

If the appliance is not used for a long period of time, the following steps must be taken:

- deactivating the device
- disconnect the power supply

⚠ To restart the appliance after it has been out of use for a long period, call in the Technical Service Centre.

MAINTENANCE

6.1 Routine maintenance

6.1.1 Annual operations

The once-a-year maintenance plan includes the following operations and checks and must be carried out by the Technical Service Centre or by qualified personnel.

Electrical circuit

Check:

- electrical supply voltage
- the electrical absorption
- connections tightening
- that there is no damage or excessive wear to electrical cables
- that the gaskets and sealing materials have not deteriorated to such an extent that they are no longer suitable for the purpose of preventing the development of flammable atmospheres inside
- the correct fixing of cable glands
- safety devices

Mechanical checks

Check:

- tightening of the screws, fans and electrical box, of the unit's external panelling

- the state of the structure

⚠ Bad fixings result in abnormal noise and vibration.

⚠ If oxidised parts are present, treat them with suitable paints to eliminate or reduce oxidation.

Hydraulic controls

Check:

- the regular drainage of condensate
- cleaning the condensate collection trays
- cleaning the exhaust ducts

Airflow controls

Check:

- the regular flow of air
- cleaning of any intake grids
- cleaning the ducting

Cleaning

- cleaning or filter replacement
- cleaning the heat exchanger

6.1.2 Cleaning or filter replacement

Unit without accessories

1. Lower filter guide

2. Filter

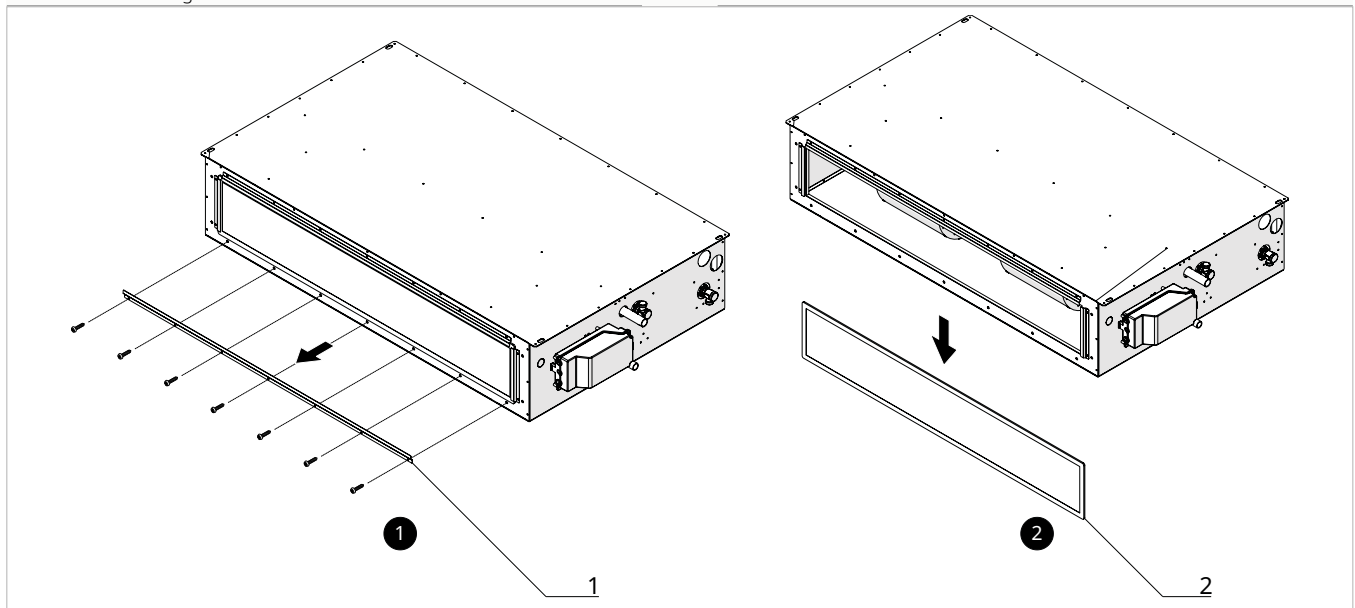

1. Side filter guide

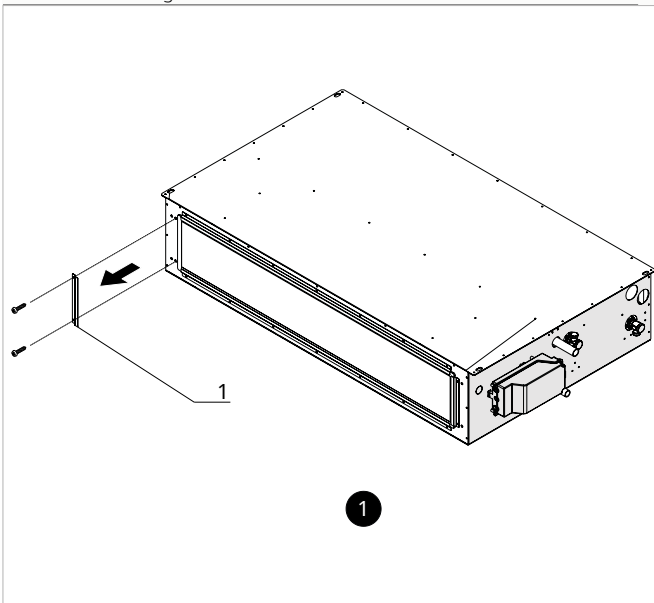

2. Filter

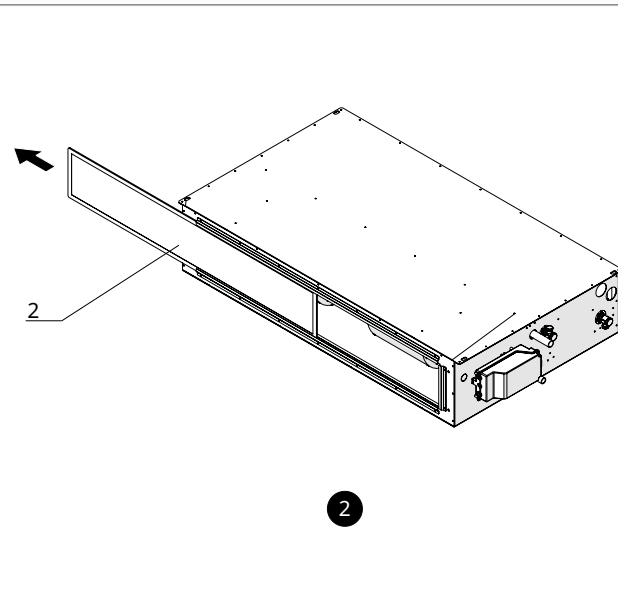

To remove:

- disconnect the power supply to the unit
- remove the screws from the lower or side filter guide
- remove the lower or side filter guide
- take out the filter

⚠ Pay attention to sharp surfaces

- ⓘ If the condition of the filters is acceptable, they can be cleaned using a vacuum cleaner or a low-pressure compressor.
- ⓘ If it is impossible to clean them, the filters must be replaced.

To reposition:

- proceed in reverse order

Unit with extracted air plenum

1. Filter port

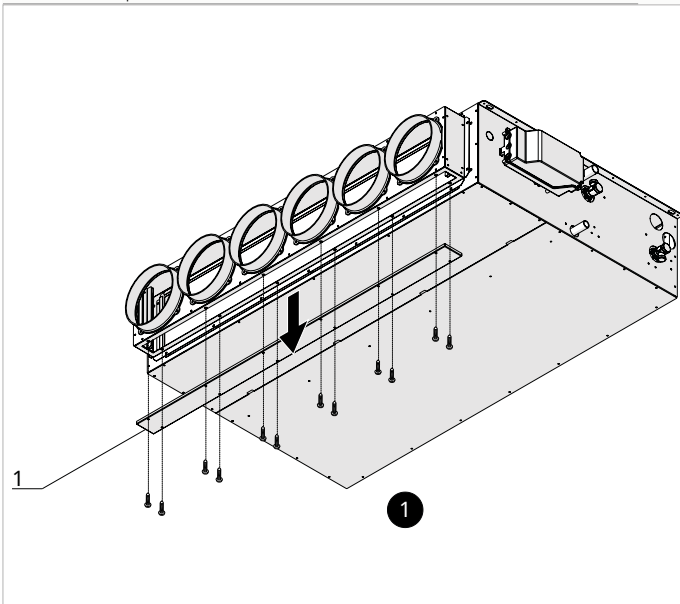

2. Filter

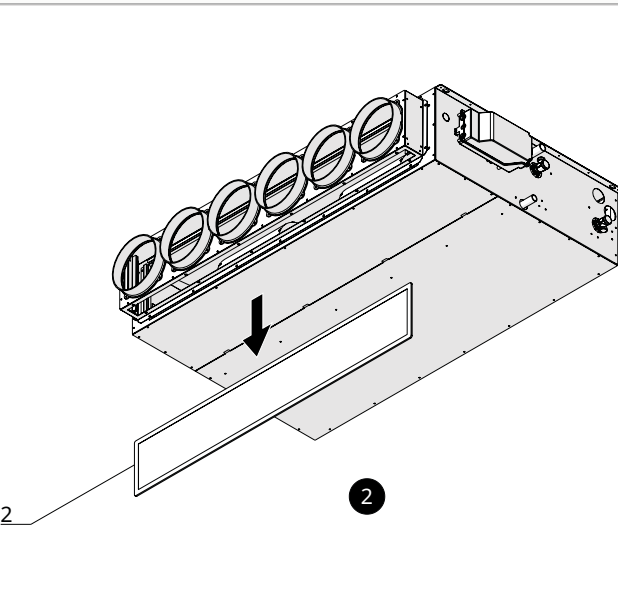

To remove:

- disconnect the power supply to the unit
- remove the screws from the filter port
- remove the filter port
- take out the filter

⚠ Pay attention to sharp surfaces

- ⓘ If the condition of the filters is acceptable, they can be cleaned using a vacuum cleaner or a low-pressure compressor.
- ⓘ If it is impossible to clean them, the filters must be replaced.

To reposition:

- proceed in reverse order

6.1.3 Cleaning the heat exchanger

Cleaning the heat exchanger

1. Lower panel

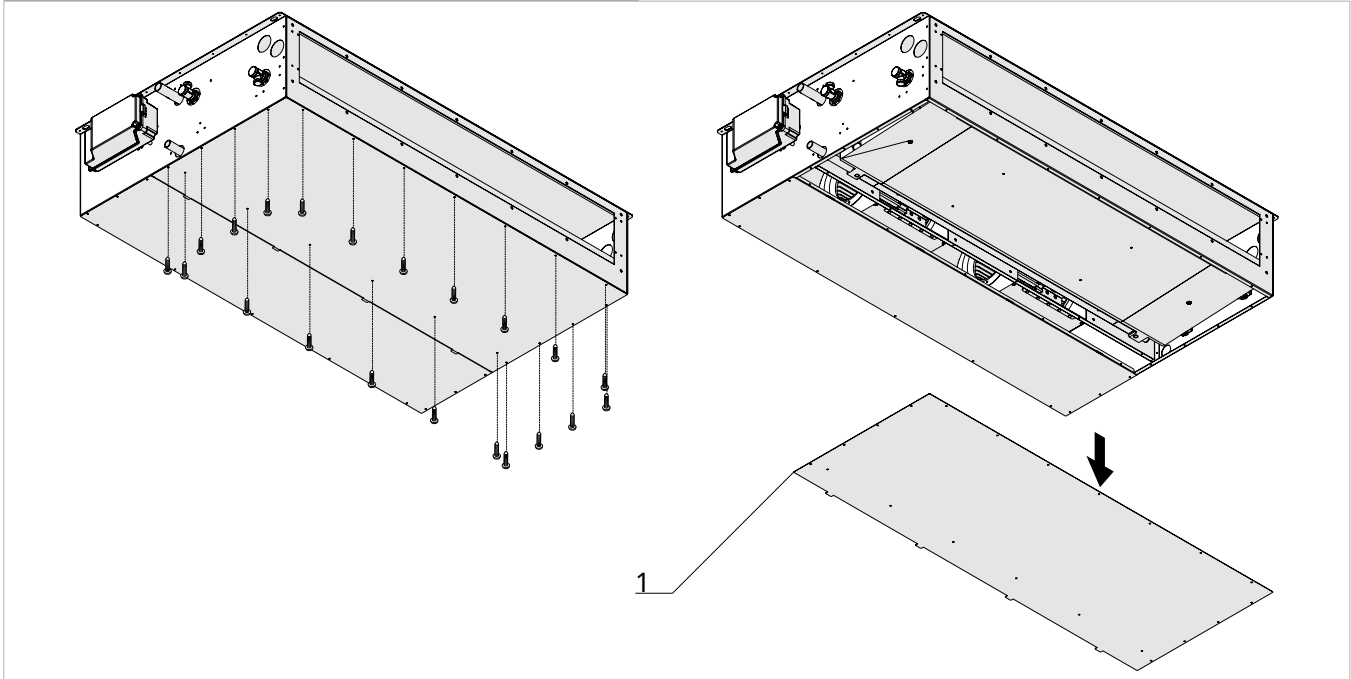

1. Heat exchanger

2. Condensate collection tray

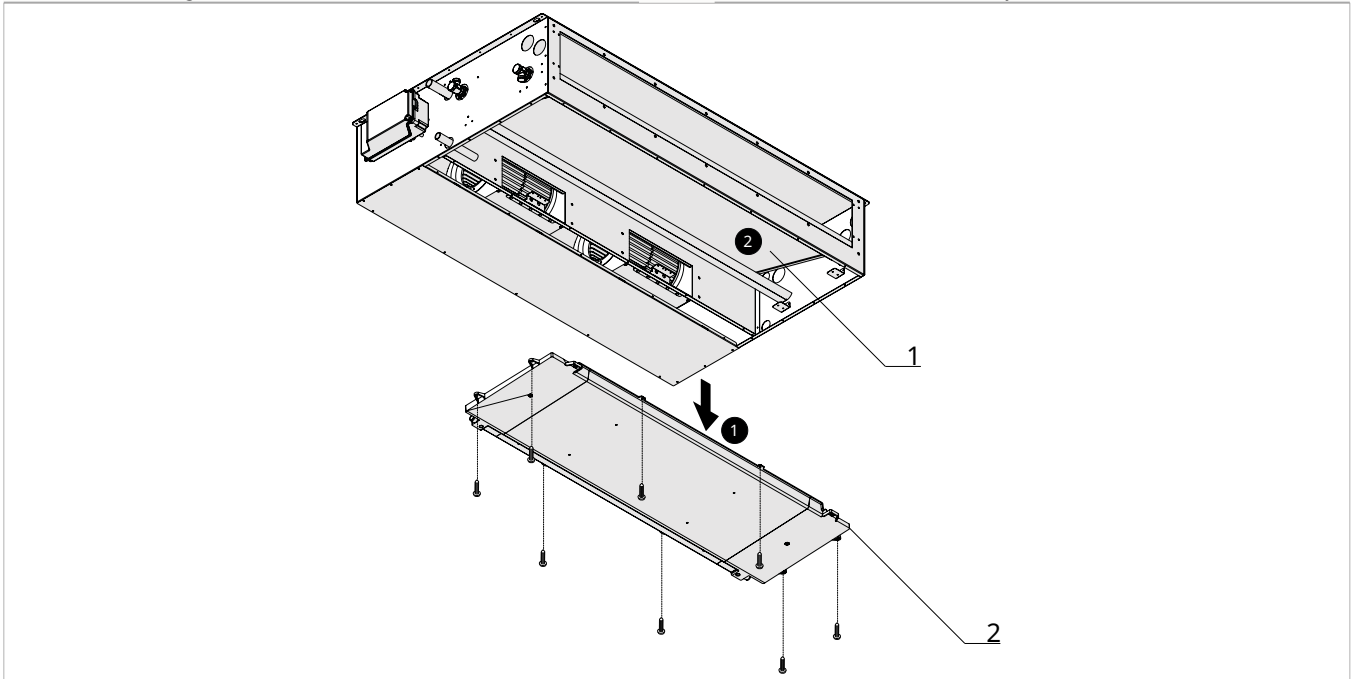

- disconnect the power supply to the unit
- disconnect the condensate drain pipe
- access the heat exchanger
- gently proceed with the cleaning of the heat exchanger using a vacuum cleaner or a low-pressure compressor

To reposition:

- proceed in reverse order

⚠ Never touch the fins of the heat exchanger.

FAULTS AND REMEDIES

7.1 Preliminary Warnings

If one of the following faults is found:

- the ventilation does not activate even if hot or cold water is present in the hydraulic circuit
- the appliance is leaking water during heating operation
- the appliance is leaking water only in cooling mode
- the appliance makes excessive noise
- there is dew formation on the front panel

Follow the instructions below:

- immediately disconnect the power supply
- close the water valves
- contact an authorized service center or professionally qualified personnel

⚠ Work must be carried out by a qualified installer or a specialised service centre.

⊘ Personal intervention is prohibited.

7.2 Troubleshooting Table

DESCRIPTION OF FAULT	CAUSE	REMEDY
The fans are not active	The power supply is not switched on	Check the power supply on the fan
	The fan speed regulation device does not work	Check fan speed regulation device
	Incorrect electrical connections	Check electrical connections.
Insufficient air flow or pressure	Clogged filters	Clean filters
	Insufficient rotation speed	Increase rotation speed
	Piping or exchanger clogged	Clean piping or heat exchanger
Insufficient heat exchanger efficiency	Exchanger fins clogged	Clean exchanger surfaces
Excessive vibration and noise	Incorrect installation of the unit	Check unit brackets and fastenings
	Incorrect piping installation	Check brackets and pipe fixings
	Fan impeller imbalance	Check fan impeller condition
Water leaks from unit	Clogged condensate drain	Clean condensate drain
	Siphon not installed correctly	Check the correct installation of the siphon
Difficult start-up	Supply voltage too low	Check that the supply voltage is not below 10% of the rated voltage

7.3 Alarm table and card flashes

DESCRIPTION OF ALARM	CAUSE	REMEDY	CARD FLASHES
AIR intake probe alarm	Sensor breakage or failure to read	Check probe connection or replace sensor	1 flash - off 3 seconds
Water temperature alarm	Water request detected by the H2 probe not met (above 20 °C in cooling, below 30 °C in heating). It involves stopping the fan until the temperature reaches a suitable value to fulfill the request.	Check the water temperature or the positioning of the H2 probe	1 flash - off 3 seconds
Fan alarm	Fan connector faulty or feedback signal absent	Check the connection of the fan connector to the board Replace fan control cable	2 flashes - off 3 seconds
Filters alarm	counter reached	Replace filters and reset	-
Water probe alarm	Sensor breakage or failure to read	Check probe connection or replace sensor	3 flashes - off 3 seconds
Remote display connection alarm	Remote display connection error	Check electrical connections. Check that A and B are not reversed Check the correct insertion of the display connection board on the main board	LED off
Remote display communication alarm	No communication between display and board for at least 300 seconds	Check that A and B are not reversed Check the correct insertion of the display connection board on the main board	6 flashes - off 3 seconds
Open GRID contact	Open GRID contact on the board	Check the presence of the closed bridge or connected contact	Continuous high-frequency flashing

TECHNICAL INFORMATION

8.1 Technical data

Models	u.m.	400	600	800	1000	1200
Fancoil airflow performance						
Maximum flow rate	m ³ /h	390	560	730	905	1150
Medium air flow	m ³ /h	260	350	440	550	750
Minimum air flow	m ³ /h	120	180	240	260	280
Available pressure	Pa	90	130	110	140	140
Heating performance (W 45; A 20) (1)						
Total power output	kW	1,98	2,54	3,45	4,46	6,20
Water flow rate	L/h	390	550	670	910	1100
Pressure drop	kPa	12,25	21,45	2,92	18,37	19,00
Maximum absorbed power	W	24	21	34	38	85
Maximum sound power	dB(A)	58	58	57	58	60
Cooling performance (W 7; A 27) (2)						
Total power output	kW	1,88	2,14	2,97	3,48	5,90
Sensible heat capacity	kW	1,48	1,56	2,92	2,95	5,00
Water flow rate	L/h	330	520	600	760	1000
Pressure drop	kPa	15,66	19,36	2,93	14,00	16,00
Maximum absorbed power	W	24	21	34	38	85
Maximum sound power	dB(A)	58	58	57	58	60
Room side fan						
Type		Forward-curved EC Brushless centrifugal fan				
Number	No.	1	1	2	2	3
Maximum absorbed current	A	0,37	0,65	0,74	0,74	1,04
Maximum absorbed power	W	85	150	170	170	240
Room side sound levels (UNI EN 3741; 3744) (3)						
Sound power transmitted to the Lw structure	dB (A)	55,0	59,0	60,0	62,0	63,0
Sound power radiated in the Lw channel	dB (A)	59,0	64,0	68,0	69,0	71,0
Average sound pressure at 1 m Lp	dB(A)	43,0	46,0	48,0	49,0	50,0
Average sound pressure at 3 m Lp	dB(A)	37,0	38,0	40,0	41,0	42,0
Heat exchanger (W 7; W 12) (4)						
Coil water content	L	0,80	1,13	1,46	1,80	2,14
Maximum operating pressure	bar	10	10	10	10	10
Electrical characteristics						
Power supply	V / ph / Hz	230 / 1 / 50				
Maximum total absorbed power	W	85	150	170	170	240
Total absorbed current	A	0,70	1,30	1,30	1,50	1,90
Protection rating	IP	X0				
Product dimensions						
Width	mm	590	790	990	1190	1440
Length	mm	695	695	695	695	695
1. Coil water temperature 45/40 °C; Room temperature 20 °C (EU Regulation 2016/2281) 2. Coil water temperature 7/12 °C; Room temperature 27 °C b.s. and 19° C b.u. (EU Regulation 2016/2281) 3. Data refers to the UNI EN 3741 and UNI EN 3744 standards 4. Supply water temperature 7 °C; Return water temperature 12 °C						

Models	u.m.	400	600	800	1000	1200
Height	mm	240	240	240	240	240
Weight	kg	32,0	43,0	47,0	56,0	67,0
Connections						
Condensate drain connection	mm	20	20	20	20	20
Hydraulic connections	"EK	3/4"	3/4"	3/4"	3/4"	3/4"
Supply air connection (base x height)	mm	460 × 150	660 × 150	860 × 150	1060 × 150	1320 × 150
Extracted air connection (base x height)	mm	510 × 150	710 × 150	910 × 150	1110 × 150	1370 × 150
1. Coil water temperature 45/40 °C; Room temperature 20 °C (EU Regulation 2016/2281) 2. Coil water temperature 7/12 °C; Room temperature 27 °C b.s. and 19° C b.u. (EU Regulation 2016/2281) 3. Data refers to the UNI EN 3741 and UNI EN 3744 standards 4. Supply water temperature 7 °C; Return water temperature 12 °C						

8.2 Dimensions

Size 40

- A** Hydraulic connection for water outlet from the unit
- B** Hydraulic connection Water inlet to the unit
- C** Vertical condensate drain installation

- D** Horizontal condensate drain installation
- E** Electrical panel

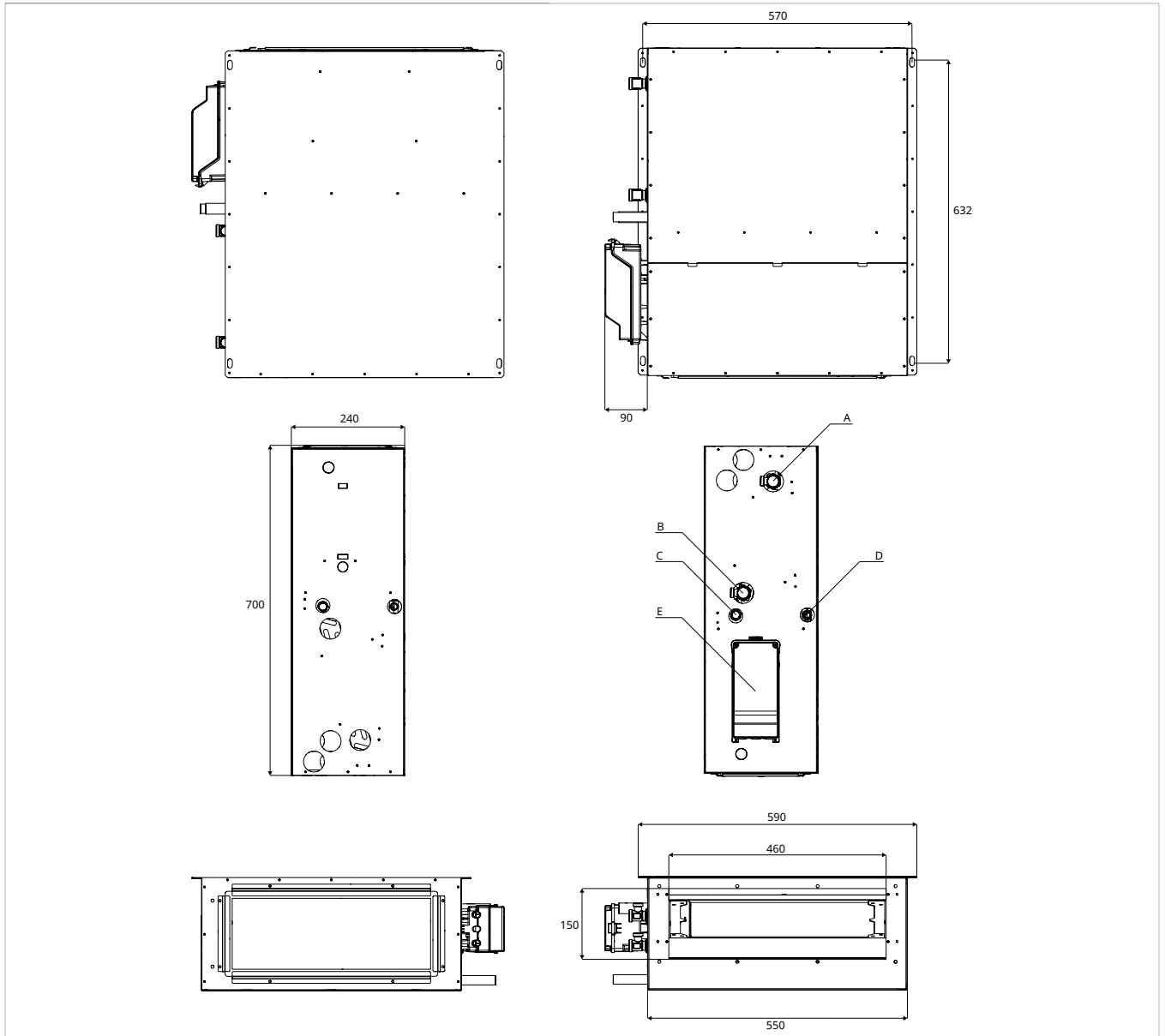

Size 60

- A** Hydraulic connection for water outlet from the unit
- B** Hydraulic connection Water inlet to the unit
- C** Vertical condensate drain installation

- D** Horizontal condensate drain installation
- E** Electrical panel

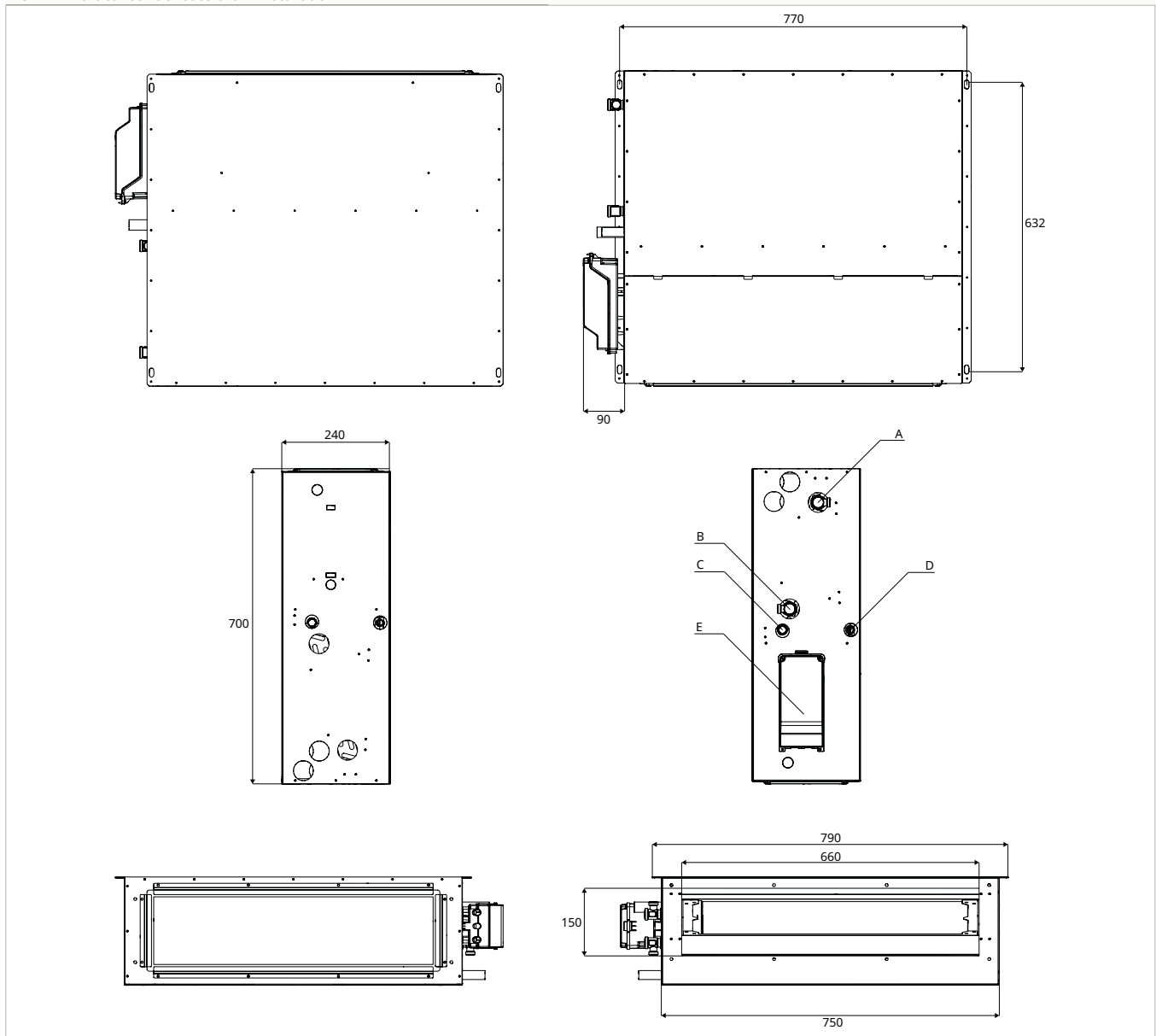

Size 80

- A** Hydraulic connection for water outlet from the unit
- B** Hydraulic connection Water inlet to the unit
- C** Vertical condensate drain installation

- D** Horizontal condensate drain installation
- E** Electrical panel

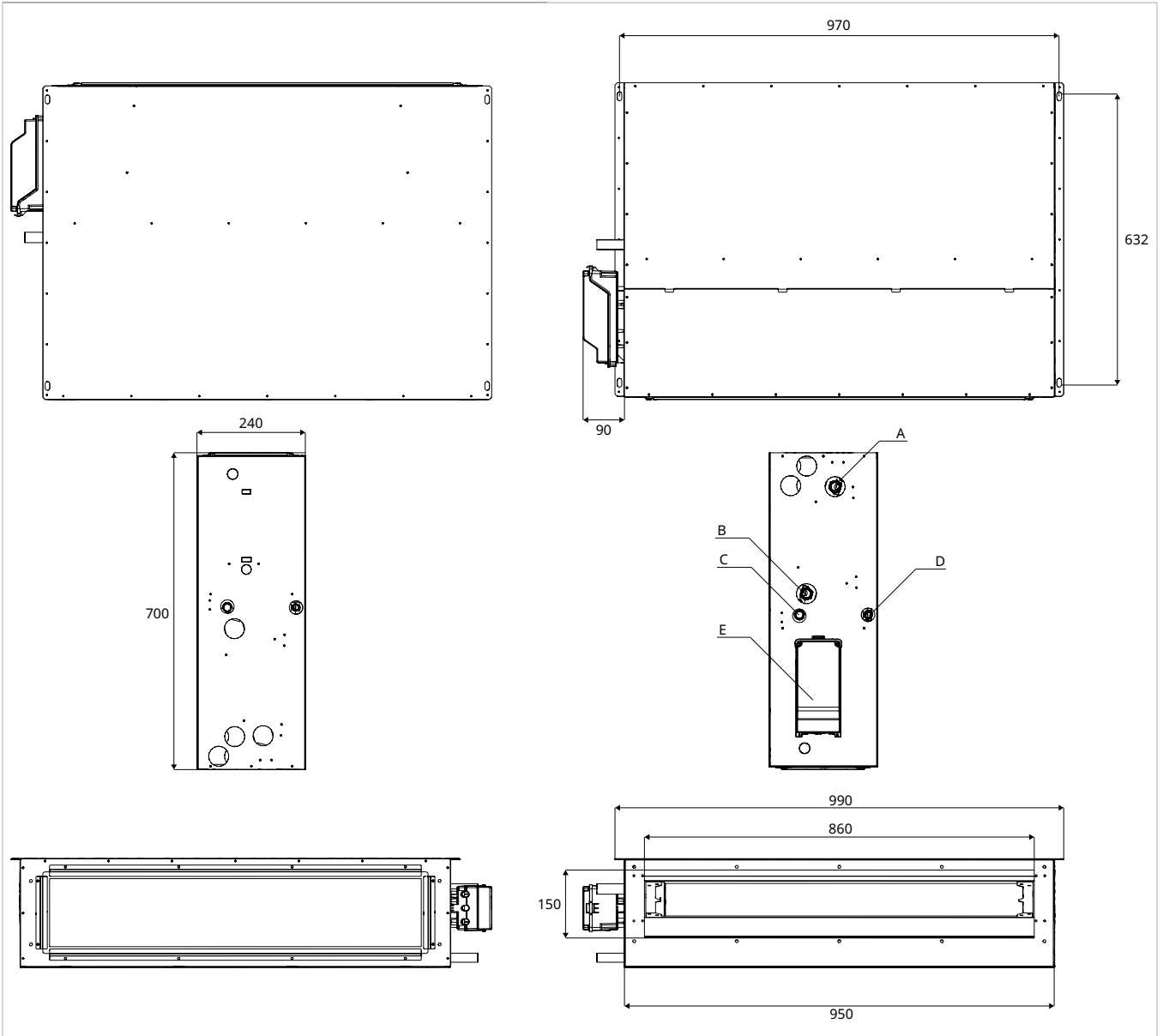

Size 100

- A** Hydraulic connection for water outlet from the unit
- B** Hydraulic connection Water inlet to the unit
- C** Vertical condensate drain installation

- D** Horizontal condensate drain installation
- E** Electrical panel

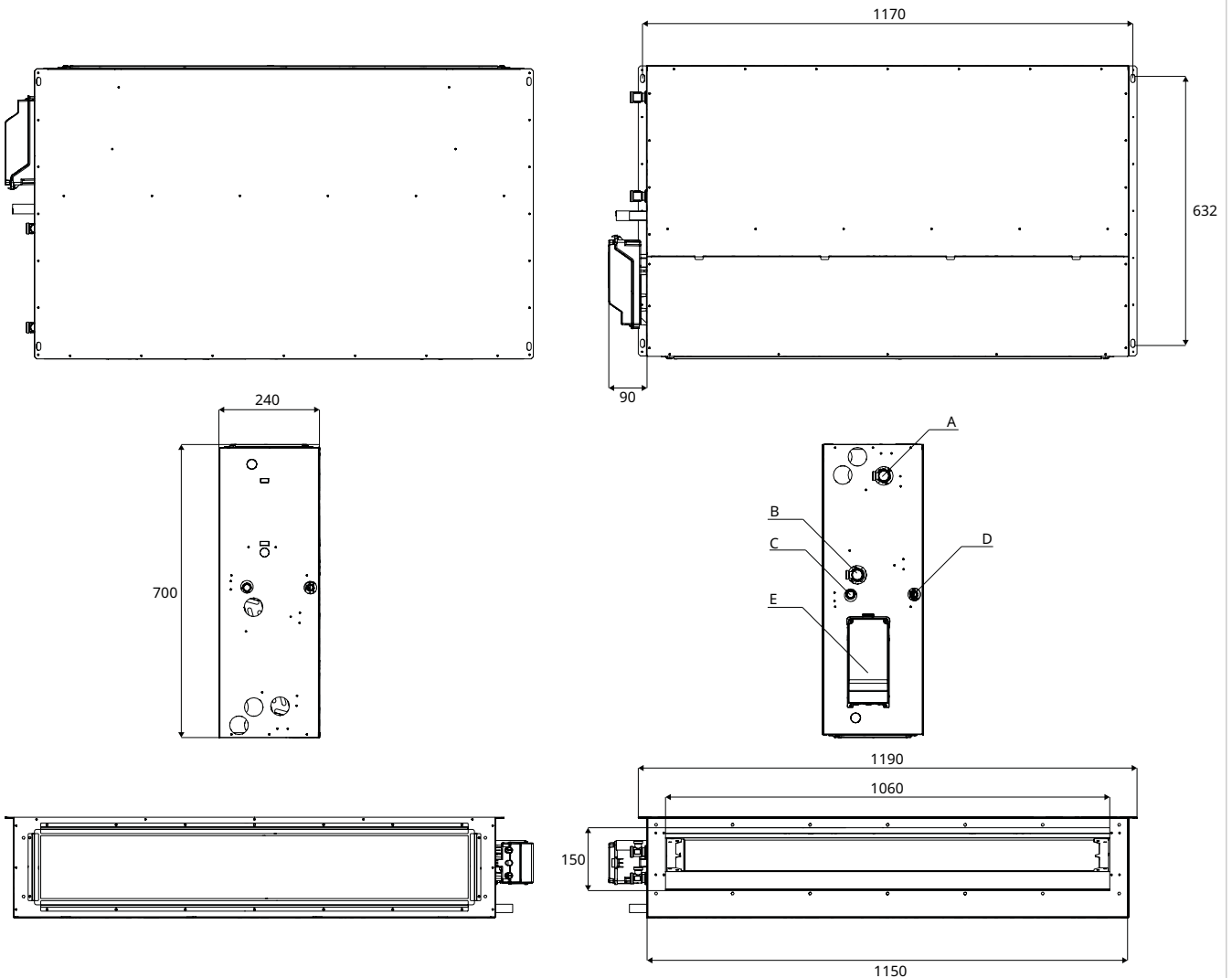

Size 120

- A** Hydraulic connection for water outlet from the unit
- B** Hydraulic connection Water inlet to the unit
- C** Vertical condensate drain installation

- D** Horizontal condensate drain installation
- E** Electrical panel

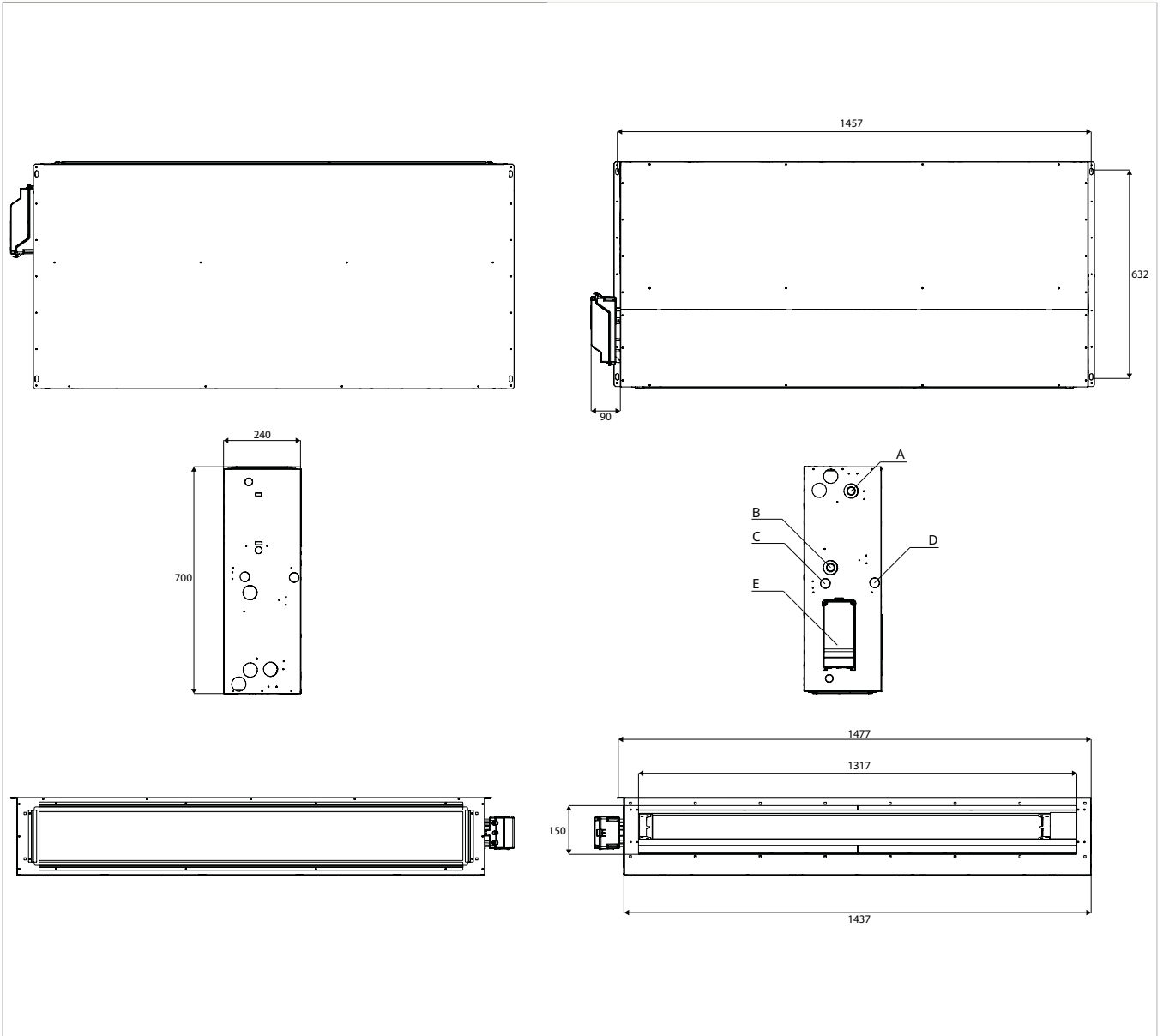

INNOVA S.r.l.
Via I Maggio 8 - 38089 (TN) - ITALY
tel. +39.0465.670104 - fax +39.0465.674965
info@innovaenergie.com