

Installation Manual
(Translation of original
instructions)

EN



innova

N420942A - Rev. 01 - 04/2024

>OSMO<

SL - RS

First of all, we would like to thank you for having chosen a device of our production.

We are sure you will be happy with it because it represents the state of the art in the technology of home air conditioning.

By following the suggestions contained in this manual, the product you have purchased will operate without problems giving you optimum room temperatures with minimum energy costs.

INNOVA S.r.l.

Conformity

This unit complies with the European directives:

- Low voltage 2014/35 / EU
- Electromagnetic compatibility 2014/30 / EU
- RoHS 2011/65/UE
- Regulation (EU) No. 2016/2281 implementing Directive 2009/125/EC

Markings



TABLE OF CONTENTS

1	Coding	<u>p. 5</u>
1.1	Product related coding	<u>p. 5</u>
2	General information	<u>p. 6</u>
2.1	About the manual.	<u>p. 6</u>
2.1.1	Editorial pictograms	<u>p. 6</u>
2.1.2	Pictograms on the product.	<u>p. 6</u>
2.1.3	Recipients	<u>p. 6</u>
2.1.4	Manual organisation	<u>p. 6</u>
2.2	General warnings	<u>p. 7</u>
2.3	Basic rules of security	<u>p. 7</u>
2.4	Disposal.	<u>p. 8</u>
3	Product presentation	<u>p. 9</u>
3.1	Identification	<u>p. 9</u>
3.2	Destination of use.	<u>p. 9</u>
3.3	Description of the appliance	<u>p. 9</u>
3.4	Components	<u>p. 10</u>
3.5	Compatible accessories	<u>p. 11</u>
4	Installation	<u>p. 13</u>
4.1	Preliminary warnings.	<u>p. 13</u>
4.2	Reception.	<u>p. 13</u>
4.2.1	Preliminary warnings	<u>p. 13</u>
4.2.2	Package description	<u>p. 13</u>
4.3	Dimensions and weights with packaging	<u>p. 13</u>
4.4	Handling with packaging	<u>p. 14</u>
4.4.1	Preliminary warnings	<u>p. 14</u>
4.4.2	Movement methods	<u>p. 14</u>
4.5	Storage	<u>p. 14</u>
4.5.1	Preliminary warnings	<u>p. 14</u>
4.6	Unpacking	<u>p. 14</u>
4.6.1	Preliminary warnings	<u>p. 14</u>
4.6.2	Remove the package	<u>p. 15</u>
4.7	Handling without packaging	<u>p. 15</u>
4.7.1	Preliminary warnings	<u>p. 15</u>
4.7.2	Movement methods	<u>p. 15</u>
4.8	Installation site	<u>p. 15</u>
4.8.1	Preliminary warnings	<u>p. 15</u>
4.9	Installation mode	<u>p. 16</u>
4.10	Installation minimum distances	<u>p. 16</u>
4.11	Positioning	<u>p. 16</u>

4.11.1	Preliminary warnings	<u>p. 16</u>
4.11.2	Device preparation	<u>p. 17</u>
4.11.3	Positioning for vertical configurations	<u>p. 18</u>
4.11.4	Positioning for horizontal configurations.	<u>p. 19</u>
4.12	Hydraulic connections	<u>p. 20</u>
4.12.1	Preliminary warnings	<u>p. 20</u>
4.12.2	Position and dimensions.	<u>p. 20</u>
4.12.3	System connection	<u>p. 20</u>
4.12.4	Shut-off valves	<u>p. 20</u>
4.13	Condensation drain preparation	<u>p. 21</u>
4.13.1	Preliminary warnings	<u>p. 21</u>
4.13.2	Condensate drain dimensions	<u>p. 21</u>
4.13.3	Connection for vertical installations	<u>p. 21</u>
4.13.4	Connection for horizontal installations.	<u>p. 22</u>
4.13.5	Check.	<u>p. 22</u>
4.14	Filling the system	<u>p. 23</u>
4.14.1	Mounting the thermostatic head	<u>p. 23</u>
4.15	Electric connections	<u>p. 24</u>
4.15.1	Preliminary warnings	<u>p. 24</u>
4.15.2	Power line dimensioning	<u>p. 24</u>
4.15.3	Access to the terminal block	<u>p. 24</u>
4.15.4	Power supply connection	<u>p. 25</u>
5	Maintenance	<u>p. 26</u>
5.1	Preliminary warnings.	<u>p. 26</u>
5.2	Routine maintenance.	<u>p. 26</u>
5.2.1	External cleaning	<u>p. 26</u>
5.2.2	Air intake filter cleaning	<u>p. 27</u>
5.3	Suggestions for energy saving	<u>p. 27</u>
6	Troubleshooting	<u>p. 28</u>
6.1	Preliminary warnings.	<u>p. 28</u>
6.2	Troubleshooting table	<u>p. 28</u>
7	Configuration accessories	<u>p. 29</u>
7.1	Shut-off valves.	<u>p. 29</u>
7.1.1	Connection with manual 2-way valve	<u>p. 29</u>
7.1.2	Connection with 2-way valves with thermoelectric motor.	<u>p. 30</u>
7.1.3	Connection with 3-way diverter valves with thermoelectric motor	<u>p. 31</u>
8	Technical information.	<u>p. 32</u>
8.1	Technical data	<u>p. 32</u>
8.2	Dimensions	<u>p. 33</u>
8.3	Installation template	<u>p. 34</u>

CODING

1.1 Product related coding

This instruction manual refers to the following product codes.

⚠ Check the correspondence with the technical rating plate on the product. See chapter "Identification" [p. 9](#).

>OSMO< SL		
FAOL02DC1II	SL 200	Vertical right
FAOL02OC1II	SL 200	Left horizontal
FAOL02RC1II	SL 200	Vertical right
FAOL02SC1II	SL 200	Vertical left
FAOL04DC1II	SL 400	Vertical right
FAOL04OC1II	SL 400	Left horizontal
FAOL04RC1II	SL 400	Vertical right
FAOL04SC1II	SL 400	Vertical left
FAOL06DC1II	SL 600	Vertical right
FAOL06OC1II	SL 600	Left horizontal
FAOL06RC1II	SL 600	Vertical right
FAOL06SC1II	SL 600	Vertical left
FAOL08DC1II	SL 800	Vertical right
FAOL08OC1II	SL 800	Left horizontal
FAOL08RC1II	SL 800	Vertical right
FAOL08SC1II	SL 800	Vertical left
FAOL10DC1II	SL 1000	Vertical right
FAOL10OC1II	SL 1000	Left horizontal
FAOL10RC1II	SL 1000	Vertical right
FAOL10SC1II	SL 1000	Vertical left
>OSMO< RS		
FAOR02DC1II	RS 200	Vertical right
FAOR02SC1II	RS 200	Vertical left
FAOR04DC1II	RS 400	Vertical right
FAOR04SC1II	RS 400	Vertical left
FAOR06DC1II	RS 600	Vertical right
FAOR06SC1II	RS 600	Vertical left
FAOR08DC1II	RS 800	Vertical right
FAOR08SC1II	RS 800	Vertical left
FAOR10DC1II	RS 1000	Vertical right
FAOR10SC1II	RS 1000	Vertical left

GENERAL INFORMATION

2.1 About the manual

This manual was written to provide all the explanations for the correct management of the appliance.

⚠ This instruction manual forms an integral part of the device and therefore must be carefully preserved and must ALWAYS travel with it, even if you transfer the device to another owner or relocate it to other premises. If the manual gets damaged or lost, download a copy from the website.

⚠ Read this manual carefully before proceeding with any operation and follow the instructions in the individual chapters.

⚠ The manufacturer is not responsible for damages to persons or property caused by failure to follow the instructions in this manual.

⚠ This document is restricted in use to the terms of the law and may not be copied or transferred to third parties without the express authorization of the manufacturer.

2.1.1 Editorial pictograms

The pictograms in the next chapter provide the necessary information for correct, safe use of the machine in a rapid, unmistakable way.

Related to security

⚠ High risk warning (bold text)

- The operation described above presents a risk of serious physical injury, fatality, major damage to the appliance and/or to the environment if not carried out in compliance with safety regulations.

⚠ Low risk warning (plain text)

- The operation described above presents a risk of minor physical injury or minor damage to the appliance and/or to the environment if not carried out in compliance with safety regulations.

⊘ Prohibition (plain text)

- Refers to prohibited actions.

i Important information (bold text)

- This indicates important information that must be taken into account during the operations.

In the texts

- procedures
- lists

In the control panels

- actions required
- Expected responses following an action.*

In the figures

- 1 The numbers indicate the individual components.

A The capital letters indicate component assemblies.

1 The white numbers in black marks indicate a series of actions to be carried out in sequence.

A The black letter in white identifies an image when there are several images in the same figure.

2.1.2 Pictograms on the product

Symbols are used in some parts of the appliance:

Related to security

⚠ Caution: electrical danger

- The concerned personnel is informed to the presence of electricity and the risk of suffering an electric shock.

2.1.3 Recipients

User

Non-expert person capable of operating the product in safe conditions for people, for the product itself and the environment, interpreting an elementary diagnostic of faults and abnormal operating conditions, carrying out simple adjustment, checking and maintenance operations.

Installer

Expert person qualified to position and connect (hydraulically, electrically, etc.) the unit to the plant; this person is responsible for handling and correct installation according to the instructions provided in this manual and the national standards currently in force.

Technical Service Centre

Expert and qualified person authorised directly by the manufacturer to carry out all routine and supplementary maintenance operations, as well as every adjustment, check, repair and replacement of parts necessary during the life of the unit itself.

2.1.4 Manual organisation

The manual is divided into sections each dedicated to one or more target groups.

Coding

It addresses all recipients.

It contains the list of products and/or accessories referred to in the manual.

General information

It addresses all recipients.

It contains general information and important warnings that should be known before installing and using the appliance.

Product presentation

It addresses all recipients.

It contains the information to identify the product, its components, compatible accessories and destination of use.

Installation

It is addressed exclusively to the installer.

It contains specific warnings and all the information necessary for positioning, mounting and connecting the appliance.

Commissioning, maintenance and troubleshooting

They are addressed exclusively to the Technical Assistance Centre.

It contains specific warnings useful information for the most common commissioning and routine maintenance.

Configuration accessories

It is addressed to the installer and the Technical Assistance Centre.

It contains specific warnings and all detailed information on configuration accessories.

Technical information

It addresses all recipients.

It contains detailed technical information about the appliance.

2.2 General warnings

- ⚠ Specific warnings are given in each chapter of the document and must be read before starting operations.
- ⚠ All personnel involved must be aware of the operations and dangers that may arise when beginning all unit installation operations.
- ⚠ Installation performed outside the warnings provided in this manual and use of the appliance outside the prescribed temperature limits will invalidate the warranty.
- ⚠ The installation and maintenance of climate control equipment could be dangerous because there is live electrical components inside the appliances. The installation, initial start-up and subsequent maintenance phases must be carried out exclusively by authorised and qualified personnel (see first start-up request form enclosed with the appliance).
- ⚠ Any contractual or extra-contractual liability for damage caused to persons, animals or property, due to installation, adjustment and maintenance errors or improper use is excluded. All uses not expressly indicated in this manual are not permitted.
- ⚠ Only qualified installer companies are authorised to install the device. After having completed installation, the installer will issue a declaration of conformity to the plant manager, as required by the applicable standards and the guidelines provided by contractor's instruction manual supplied with the device.
- ⚠ First start-up and repair or maintenance operations must be carried out by the Technical Assistance Centre or by qualified personnel following the provisions of this manual.
- ⚠ Do not modify or tamper with the appliance as this can lead to dangerous situations.
- ⚠ Use suitable accident-prevention clothing and equipment during installation and/or maintenance operations. The manufacturer is not liable for the non-observance of the current safety and accident prevention regulations.
- ⚠ In the event of liquid or oil leaks, set the master switch of the plant to "off" and close the water taps. Call the authorised Technical Assistance Centre or professionally qualified personnel as soon as possible and do not work on the appliance yourself.
- ⚠ In case of replacement of parts, use only original parts.
- ⚠ The manufacturer reserves the right to make changes to its models at any time to improve its product, without prejudice to the essential characteristics described in this manual. The manufacturer is not obliged to add such modifications to machines previously manufactured, already delivered or under construction.
- ⚠ The unit can be used by children over the age of 8, and by people with reduced physical, sensory or mental capabilities, or with no experience or necessary knowledge, as long as they are monitored or after they have received instructions on the safe use of the unit and have understood the dangers involved. Children must not play with the appliance. The cleaning and maintenance that must be performed by the user should not be carried out by children without supervision.

2.3 Basic rules of security

Please keep in mind that the use of products powered by electricity and water call for operators to comply with certain essential safety rules:

- ⊖ The use of the appliance to children and unassisted disabled persons is prohibited.
- ⊖ It is forbidden to touch the device with wet or damp body parts.
- ⊖ It is forbidden to carry out any operation before disconnecting the appliance from the power supply by setting the plant master switch to "off".
- ⊖ It is forbidden to modify the safety or adjustment devices or adjust without authorization and indications of the manufacturer.
- ⊖ It is forbidden to pull, unplug or twist the device's electric cables, even if it is disconnected from the mains.
- ⊖ It is forbidden to introduce objects and substances through the air inlet and outlet grilles.
- ⊖ It is forbidden to open the access doors of the device's internal parts without first having set main switch of the system to "off".

- ⊖ It is forbidden to dispose of, or leave in the reach of children, the packaging materials which could become a source of danger.

2.4 Disposal



The symbol on the product or its packaging indicates that the product must not be treated as normal household waste, but must be taken to the appropriate collection point for the recycling of electrical and electronic equipment.

Proper disposal of this product avoids harm to humans and the environment and promotes the reuse of valuable raw materials.

For more detailed information about the recycling of this product, contact your local city office, your household waste disposal service or the shop where you purchased the product.

Illegal disposal of the product by the user involves the application of the administrative sanctions provided for by the regulations in force.

This provision is only valid in the EU Member States.

⚠ Avoid disassembling the unit yourself.

⚠ **Contact an authorised Technical Assistance Centre to disassemble the appliance.**

PRODUCT PRESENTATION

3.1 Identification

The appliance can be identified by the rating plate:

Technical rating plate

⚠ Tampering with, removal of, or lack of identification plates will not allow for the safe identification of the product by its serial number and therefore invalidates the warranty.

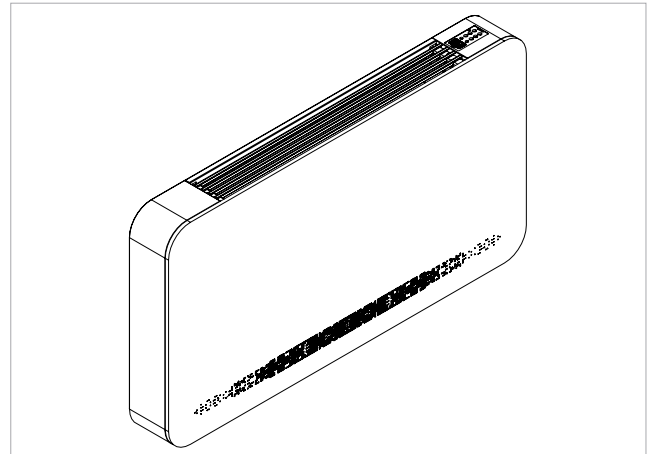

3.2 Destination of use

These appliances have been designed for conditioning and/or heating rooms and they must be destined solely for this purpose, in accordance with their performance characteristics.

They are suitable for installation on 2-pipe systems.

⊖ It is forbidden to use the device other than as indicated.

3.3 Description of the appliance

The fancoils are designed for indoor installation.

The range consists of two versions:

SL: fan convector with exposed metal cabinet

In configurations:

- vertical installation with connections on the right
- vertical installation with connections on the left
- horizontal installation with connections on the right
- horizontal installation with connections on the left

RS: fan convector with exposed metal cabinet and radiant effect

In configurations:

- vertical installation with connections on the left
- vertical installation with connections on the right

The device are made in five different performance levels and size:

- 200
- 400
- 600
- 800
- 1000

⚠ All sizes are suitable for installation only on two-pipe systems.

3.4 Components





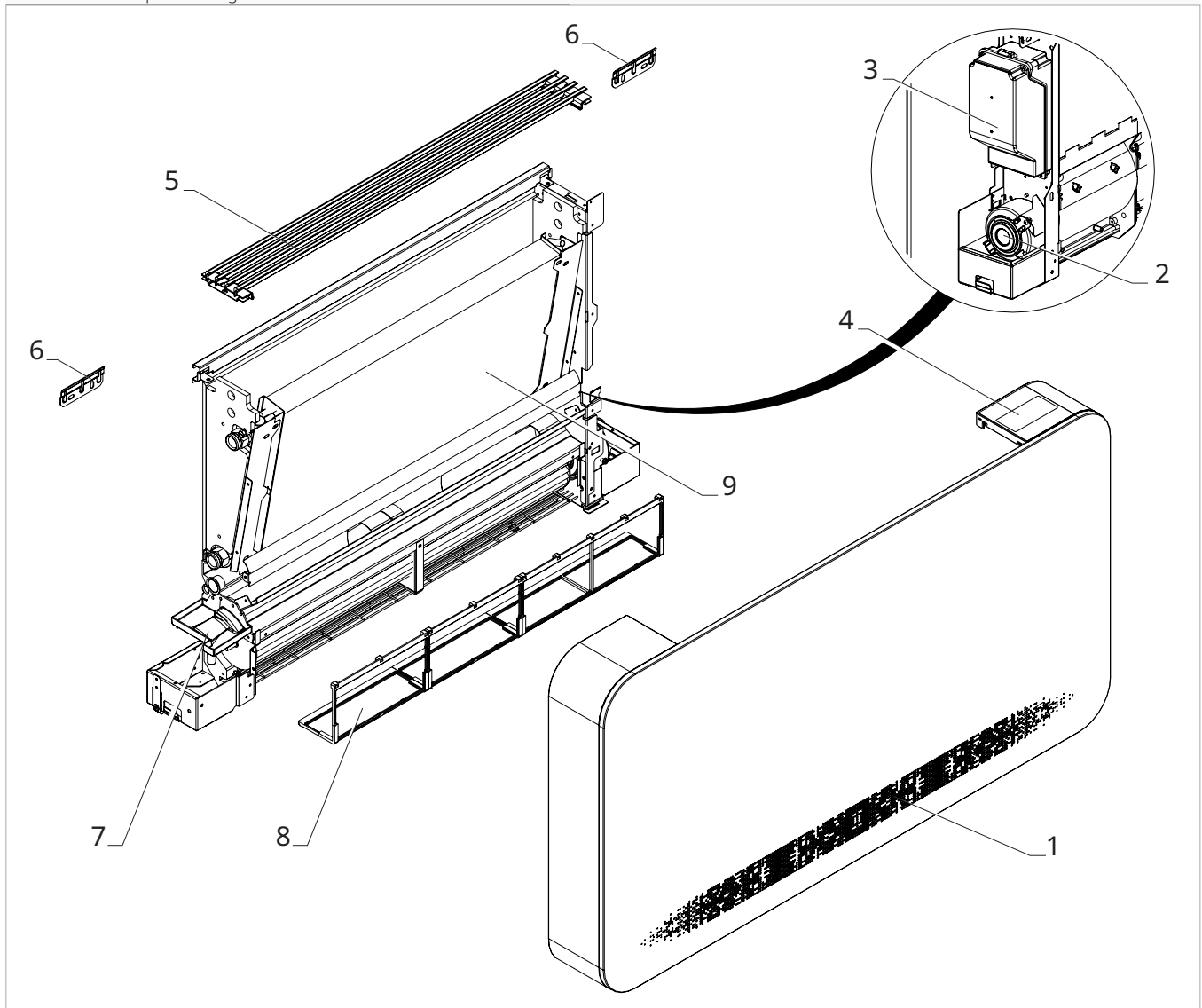

- 1. Cover cabinet
- 2. Fan motor
- 3. Electrical panel
- 4. Arrangement for on-board control M7 (accessory)
- 5. Intrusion protection grid

- 6. Wall mounting brackets
- 7. Condensation drain tray
- 8. Air filter
- 9. Heat exchanger



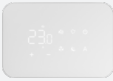



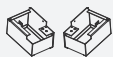

3.5 Compatible accessories

⚠ Check the matching products column for a match with the size purchased.

	Accessory description	Combinable products	Code
Controls on the appliance			
M7 controls			
	M7 on-board electronic control with continuously modulating thermostat	All	ECA844II
	M7 on-board electronic control with continuously modulating thermostat, with built-in WiFi module.	All	EWA844II
Wall-mounted control panels M7 series			
Printed circuit board M7			
	Electronic board on board unit with continuous modulation. For connection to M7 wall control units	All	ESE845II
	Electronic board on board unit with continuous modulation. For connection to M7 wall control with Bluetooth	All	ESE846II
Control panels			
	LED electronic control panel with touch interface, wall-mounted complete with thermostat and room temperature and relative humidity probe. Cable connection. Colour white	All	EEB749II
	LED electronic control panel with touch interface, wall-mounted complete with thermostat and room temperature and relative humidity probe with integrated WiFi module, InnovAPP. Cable connection. Colour white	All	EFB749II
	LED electronic control panel with touch interface, wall-mounted complete with thermostat and room temperature and relative humidity probe. Bluetooth connection. Colour white	All	EGB749II
WALL MOUNTED STANDARD FANCOIL CONTROLS			
PCB			
	On-board electronic printed circuit board for control from systems with 0-10 V analogue output.	All	B10842II
	On-board electronic printed circuit board for connection to 3-speed wall-mounted electromechanical thermostats.	All	B4V842II
Control panels			
	Wall mounted control with thermostat, summer/winter and speed selectors	All	B3V151II
Reversal attacks			
(motor connection cable for LEFT hydraulic connections)			
	Hydraulic connection reversal kit	All	BB0646II (1)
Installation accessories			
aesthetic feet			
	Feet for covering floor pipes	All	LC0158II
Feet for floor fixing			
	Feet for anchoring the unit to the floor	All	LC0606II

1. Accessories can be installed and tested at the factory

	Accessory description	Combinable products	Code
Hydraulic kit			
HYDRAULIC KIT			
	Couple of EUROKONUS adapters for 1/2" female connection (male fittings)	All	AI0200II
	Couple of EUROKONUS adapters for 3/4" female connection (male fittings)	All	AI0201II
	90° bended EUROKONUS connector	All	AI0203II
	Adaptors for flat ring	All	AI0612II
	2 way valve group with manual closure	All	I20205II (1)
	2 way valve group (water inlet valve, shut off valve and electro thermal motor)	All	V20139II (1)
	3-way diverter valve group with thermoelectric motor (complete with 3-way inlet valve and lock-shield)	All	V30720II

1. Accessories can be installed and tested at the factory

INSTALLATION

4.1 Preliminary warnings

- ⚠ **This section is dedicated to the Installer. The features of the installer are described in the "Recipients" p. 6 chapter.**
- ⚠ **For detailed information on the products, refer to chapter "Technical information" p. 32.**
- ⚠ The installation must be carried out by the installer in accordance with national installation regulations. There is a risk of water leakage, electric shock or fire if the installation is not performed correctly.
- ⚠ During the installation, it is necessary to observe the precautions mentioned in this manual, and on the labels placed inside the equipment, as well as to adopt any precaution suggested by common sense and by the Safety Regulations in force in the place of installation.
- ⚠ Be sure to use the supplied or specified installation parts. Use of other parts may cause the unit to come to lose, water leakage, electrical shock, or fire.
- ⚠ Failure to apply the indicated rules may cause malfunctions of the appliances and relieves the manufacturer from any warranty and from any damage caused to persons, animals or property.

4.2 Reception

4.2.1 Preliminary warnings

- ⚠ on receipt check them for any damage and, if any is found, accept the goods with reservation, and keep photographic evidence of any damage found
- ⚠ In the event of damage, notify the shipper within 3 days of receipt of any damage by registered mail with return receipt, submitting photographic evidence. Similar information should be sent by fax to the manufacturer (jurisdiction will be at the Court Trento for any dispute).
- ⚠ No notice of damage will be accepted after 3 days from delivery.

- ⚠ Unpack by check the contents of individual components against the packing list.

4.2.2 Package description

The packaging is made of suitable material and carried out by experienced personnel.
All units are checked and tested and are delivered complete and in perfect conditions.
The appliance is shipped in standard packaging consisting of a cardboard sleeve and a set of expanded polystyrene protectors.

4.3 Dimensions and weights with packaging

L	Total width
H	Total height
P	Total depth

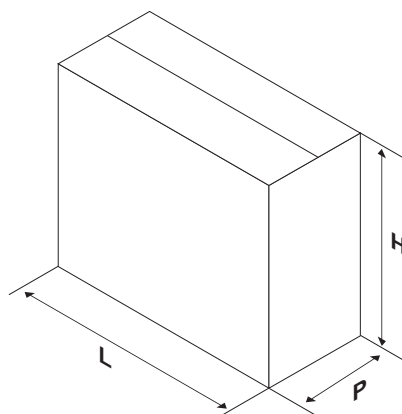

Models	m.u.	200	400	600	800	1000
Dimensions and weight for shipping						
Width	mm	825	1025	1225	1425	1625
Height	mm	665	665	665	665	665
Total depth	mm	203	203	203	203	203
Weight	kg	16,0	19,0	21,0	23,0	26,0

4.4 Handling with packaging

4.4.1 Preliminary warnings

- ⚠ The appliance must be handled only by qualified personnel, adequately equipped and with equipment suitable for the weight and dimensions of the appliance.
- ⚠ Stay clear of the area below and around it when the load is lifted off the ground.
- ⚠ Avoid dangerous situations when using a hoist to lift the appliance.

4.4.2 Movement methods

Boxes can either be carried singularly by hand by two operators or loaded on a forklift truck even stacked.

- ⚠ Check the indications on the packaging for the number of stackable packages.
- ⚠ In manual operation it is compulsory to respect always the maximum weight per person provided for by the national laws and standards.

- ⚠ Use the handles provided on the packaging.

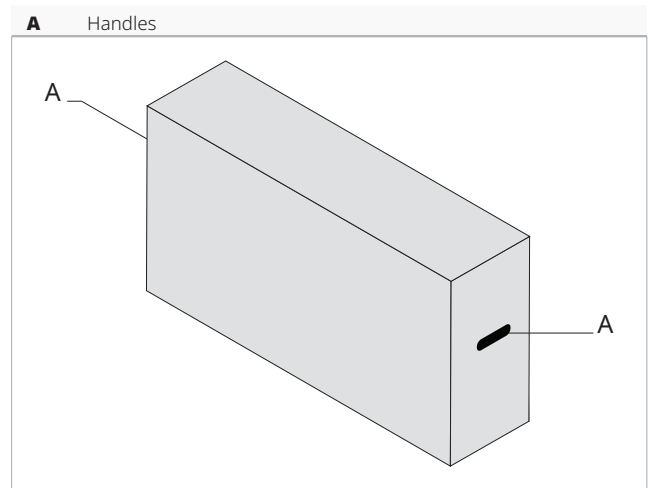

4.5 Storage

4.5.1 Preliminary warnings

- ⚠ Stored in accordance with the applicable national regulations.
- ⚠ Store the box in a closed environment protected from atmospheric agents and isolate it from the floor using planks or pallets.
- ⚠ Store in a clean and dry place.
- ⚠ Place the appliance in an vertical position.

4.6 Unpacking

4.6.1 Preliminary warnings

- ⚠ Check that no components were damaged during transport.
- ⚠ Dispose of the packaging components following the applicable waste disposal regulations. Check for disposal arrangements with your municipality.
- ⚠ Handle with care.
- ⊖ The packing material (cardboard, staples, plastic bags, etc.) must not be dispersed or abandoned in the surrounding environment and must be kept out of children reach, as it can be dangerous.

4.6.2 Remove the package

1. Protective elements

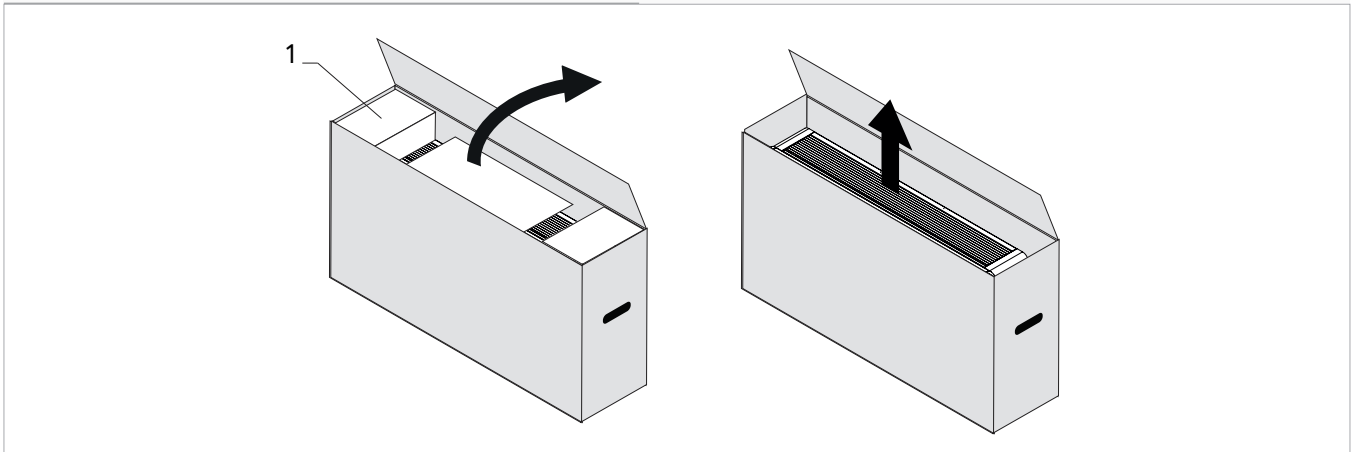

Remove the packing:

- open the cardboard packaging
- remove the metal brackets
- remove protective elements

- extract the supplied material
- remove the appliance from the box
- In case you lose it, the installation template is available on the website, in the download area.

Accompanying material

Inside the packaging are:

- 1 installation manual of unit
- 1 installation manual for controls
- 1 user manual

- 1 installation template
- 2 wall mounting brackets

⚠ Check the presence of the individual components.

4.7 Handling without packaging

4.7.1 Preliminary warnings

⚠ The appliance must be handled only by qualified personnel, adequately equipped and with equipment suitable for the weight and dimensions of the appliance.

4.7.2 Movement methods

⚠ The unit can be moved manually for short distances. In this case it is necessary to check carefully that the weight of the unit does not exceed the regulations in relation to the number of people used.

4.8 Installation site

Position of device must be established by the system designer or other qualified professional and must take into account both technical requirements and any local laws in force.

4.8.1 Preliminary warnings

⚠ Avoid installing the unit near:

- obstacles or barriers that cause recirculation of the exhaust air
- narrow places where the sound level of the appliance can be enhanced by reverberations or resonances
- environments with the presence of flammable or explosive gases
- very humid environments (laundries, greenhouses, etc.)
- environments with aggressive atmospheres
- solar radiation and proximity to heat sources
- rooms subject to high frequencies

⚠ Avoid placing the unit within 1 metre of radio and video equipment.

⚠ Do not install over heat sources.

⚠ Make sure that:

- the installation site of the unit must be chosen with the utmost care to guarantee adequate protection from shocks and consequent damage
- the wall is able to support the weight of the appliance
- the wall section does not feature building supporting elements, pipes or power lines
- the wall surface is perfectly levelled
- there are no obstacles to the free circulation of air
- the appliance must be installed in a position where it can be easily serviced
- the safety distances between the units and other appliances or structures are scrupulously respected so that the air entering and leaving the fans is free to circulate

⚠ If the appliance is installed incompletely or on an inappropriate base, it could cause damage to persons or property if it should detach from its base.

⚠ The unit should not be installed in a position where the air flow is aimed directly at the people nearby.

⚠ Provide the following:

- a nearby drain for the outflow of condensate
- a compliant power supply nearby
- fixing elements suitable for the type of support

4.9 Installation mode

⚠ For ideal installation and performance levels, carefully follow the instructions in the manual.

⚠ Failure to do so may cause system malfunctions and automatically voids the warranty, and relieves the constructor of any harm caused to person, animals or property.

4.10 Installation minimum distances

The clearance zones for the installation and maintenance of the appliance are shown in the figure. Established spaces are necessary to avoid barriers to airflow and allow for normal cleaning and maintenance.

⚠ Make sure that there is sufficient space to allow the panels to be removed for routine and supplementary maintenance operations.

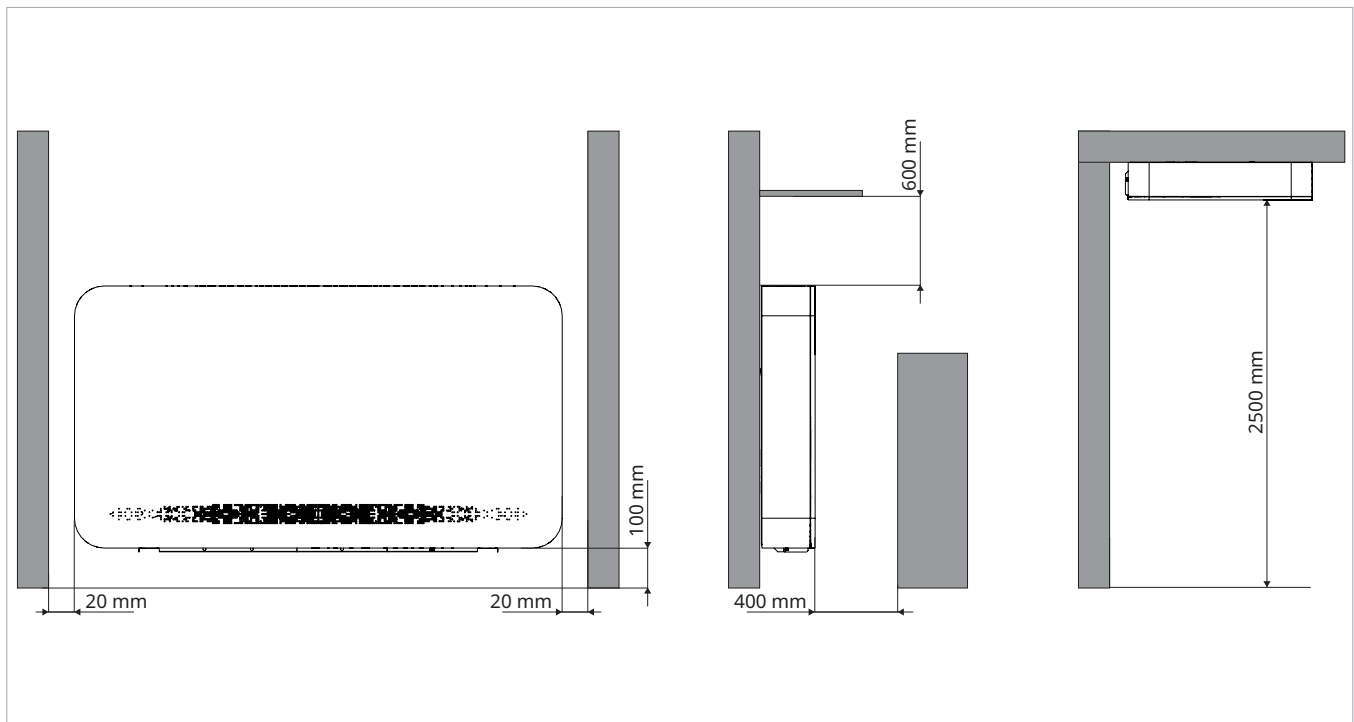

⚠ Horizontal installation is only possible for the horizontal SL version.

4.11 Positioning

ⓘ The assembly steps described below and their drawings refer to a version of the machine with connections on the left side.

4.11.1 Preliminary warnings

⚠ The unit required two or more people to position the unit.

⚠ Depending on the version you are installing, the appliance can be installed horizontally or vertically. Check the nameplate with the list in chap. "Product related coding" [p. 5](#).

⚠ Ensure that:

- the wall supports the weight of the appliance

- the section of floor or wall does not concern piping or electrical lines
- the functionality of load-bearing elements is not compromised

4.11.2 Device preparation

Before proceeding with the installation, it is necessary to remove some elements from the appliance.

⚠ The images refer to a version of the appliance with the connection on the left. If the appliance has the connection on the right side, the operation must be adapted to the position of the attacks.

Removal of upper grille

1. Fixing screws

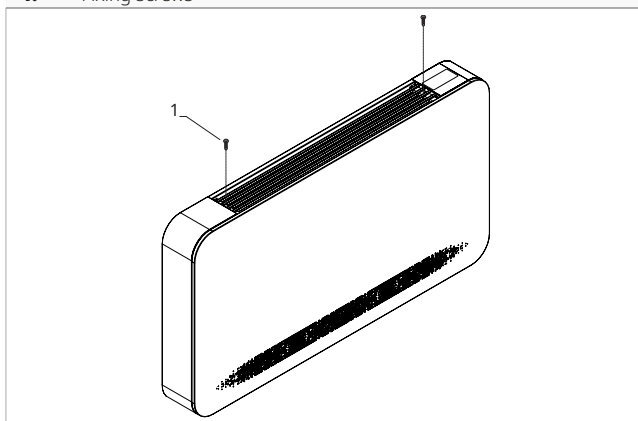

- remove the fixing screws

1. Upper grid

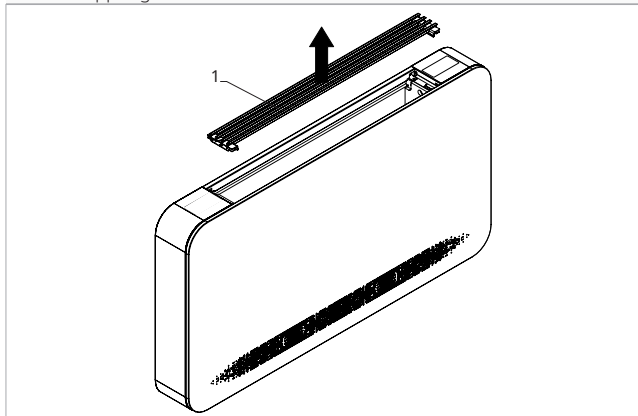

- lift up and remove the upper grille

Removal of roofing furniture

1. Fixing screws

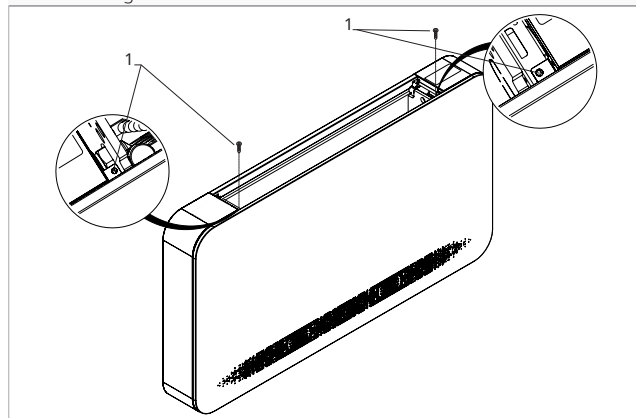

- remove the fixing screws

1. Cover cabinet

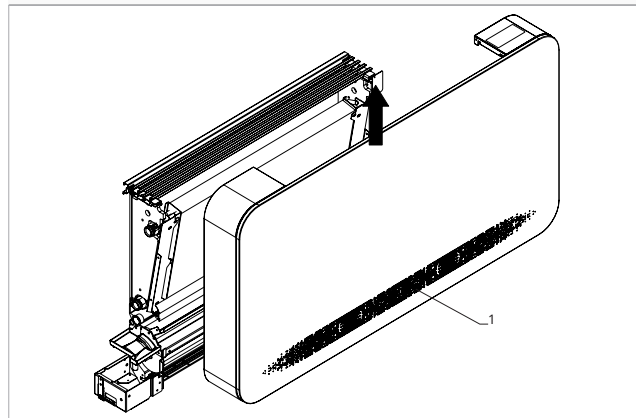

- lift the cover cabinet
- Disconnect the on-board display connector (if present)
- remove the cover cabinet

4.11.3 Positioning for vertical configurations

⚠ The units are supplied with a paper template for marking the holes necessary for installation.

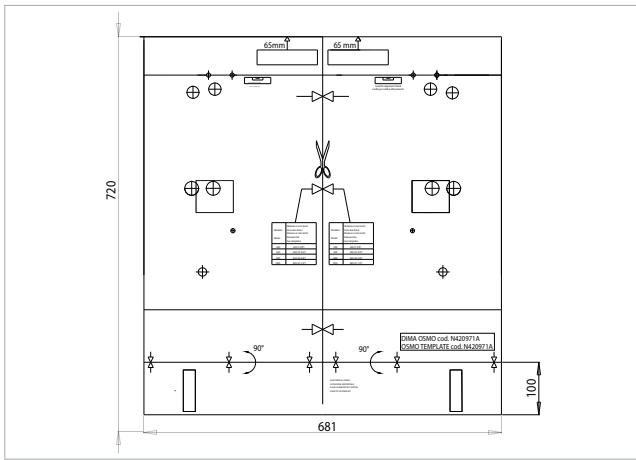

- use the paper template supplied with the device
- trace the position of the fixing brackets
- drill holes in the wall

⚠ Hold the template in the correct position with tape.

1. Plugs
2. Fixing brackets

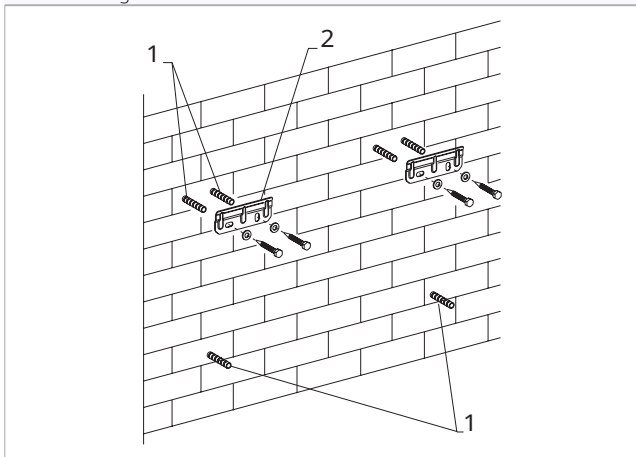

- insert the expansion plugs
- position the support brackets
- partially screw the screws

⚠ Do not fully fix the screws so that you can adjust the position of the appliance.

⚠ Use expansion plugs suitable for the chosen support wall.

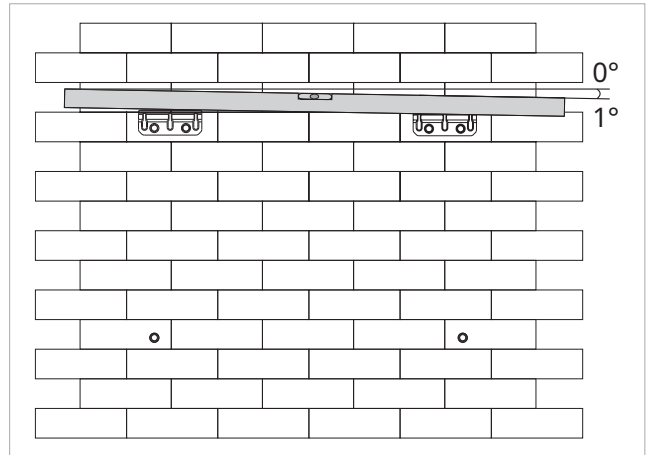

- use a leveler
- check the inclination towards the attachment side
- fix the screws

⚠ A maximum inclination of 1° towards the right side of the appliance is allowed to facilitate the drainage of condensate.

1. Fixing brackets
2. Unit
3. Fixing screws

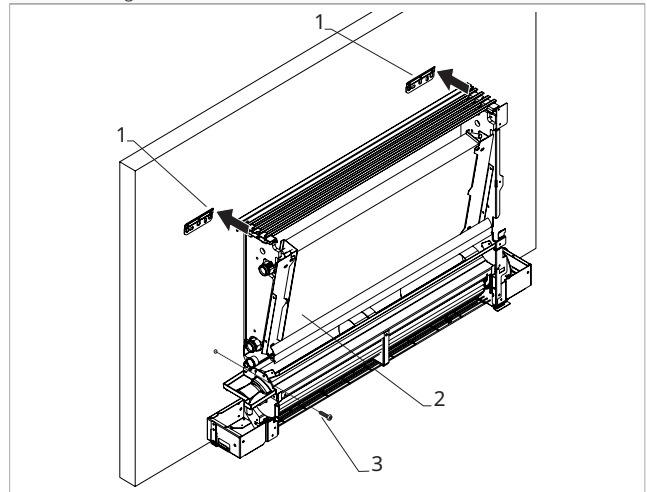

- Attach the unit to the fixing brackets
- check right attachment to the fixing brackets
- Secure the unit with the fixing screws

4.11.4 Positioning for horizontal configurations

⚠ The units are supplied with a paper template for marking the holes necessary for installation.

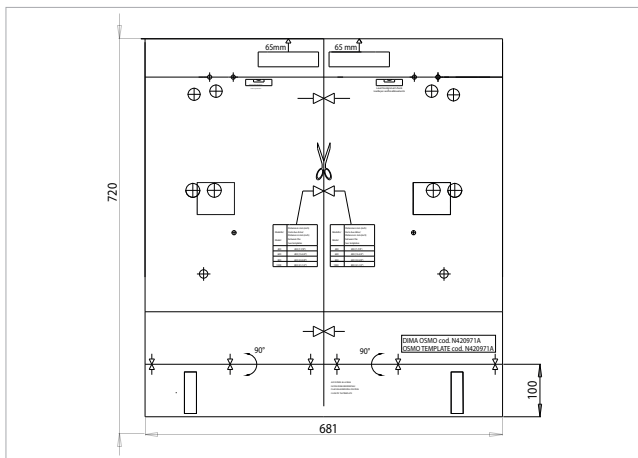

- use the paper template supplied with the device
- trace the position of the fixing brackets
- drill holes in the wall

⚠ Hold the template in the correct position with tape.

1. Plugs

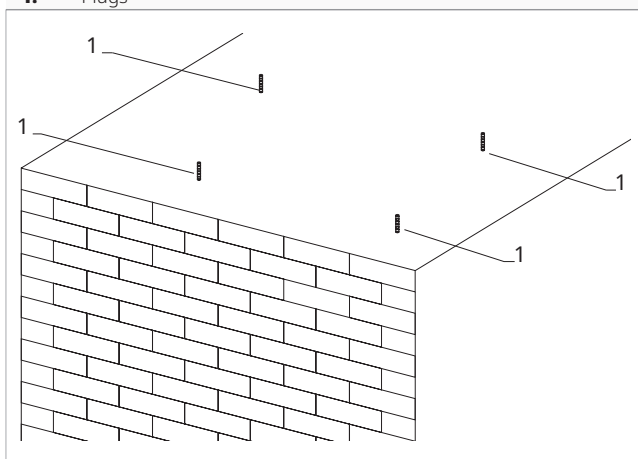

- insert the expansion plugs

1. Fixing screws

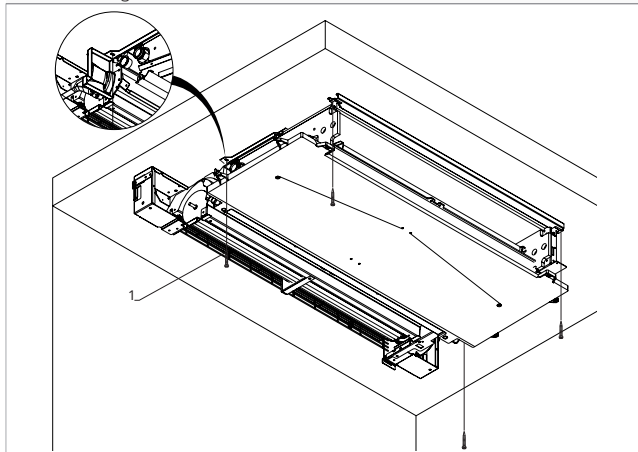

- use fixing screws
- lock the unit

⚠ Do not fully fix the screws so that you can adjust the position of the appliance.

⚠ Use expansion plugs suitable for the chosen support wall.

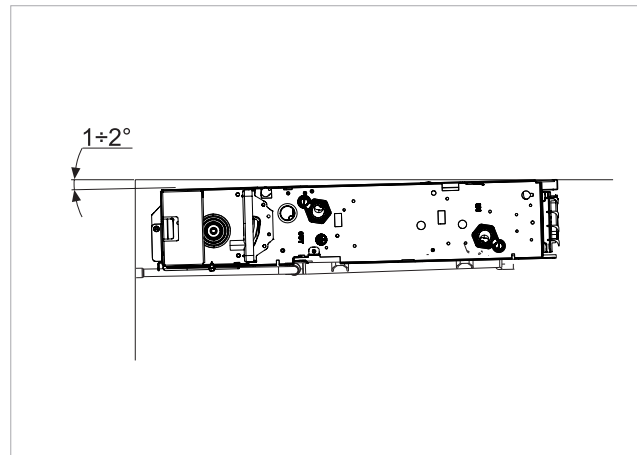

- use a leveler
- check the inclination towards the attachment side
- fix the screws

⚠ A maximum inclination of 1° toward the condensate drain connection is allowed to facilitate the drainage of condensate.

4.12 Hydraulic connections

4.12.1 Preliminary warnings

- ⚠ The engineer is responsible for choosing the right water lines and their size, in accordance with good installation practices and the applicable law.
- ⚠ The hydraulic system is made by the installer and must be carried out with reference to the diagrams in this manual or on the website.

- ⚠ The hydraulic pipes connecting to the appliance must be suitably sized for the actual water flow required by the system in operation.
- ⚠ Undersized pipelines lead to poor system operation and/or a loss of thermal and cooling performance.

4.12.2 Position and dimensions

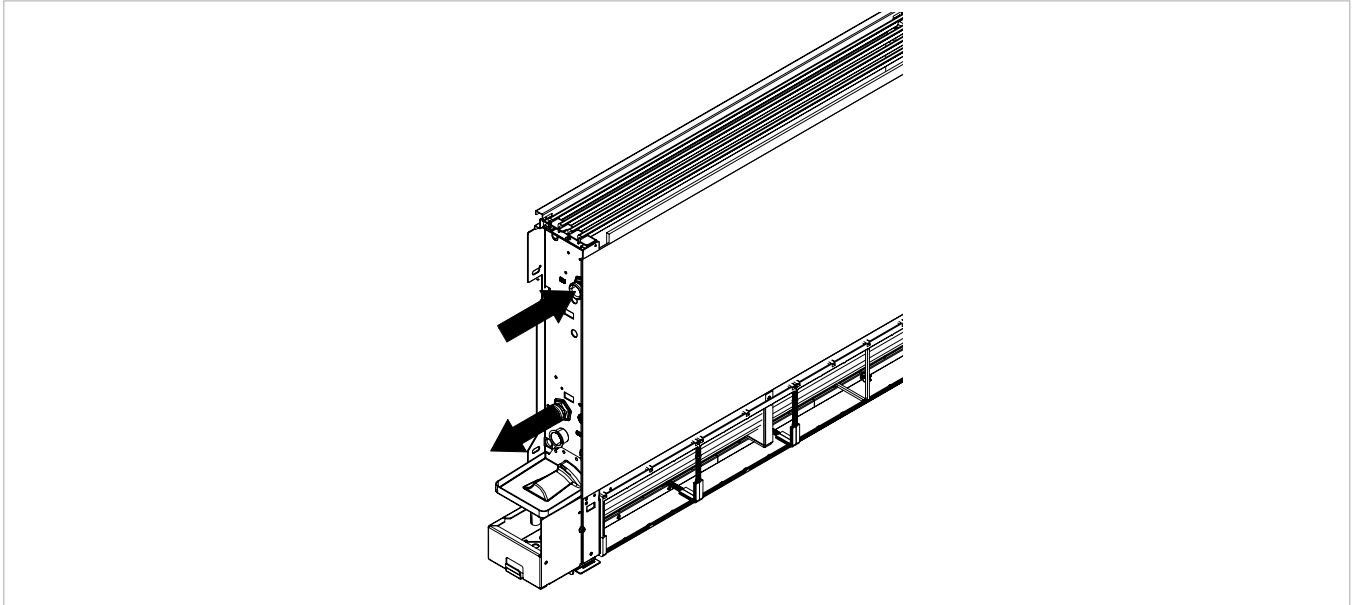

Models	m.u.	200	400	600	800	1000
Pipeline diameter	mm	14	14	16	18	20

- ⚠ For dimensional information, refer to chapter "Technical information" [p. 32](#).

4.12.3 System connection

To make the connections:

- hydraulic lines positioning
- tighten the connections
- check for leaks
- coat the connections with insulating material
- ⚠ The hydraulic lines and fittings must be thermally insulated.
- ⚠ Avoid partial insulation of the pipes.
- ⚠ Avoid over-tightening the pipes to avoid damage to the insulation.
- ⚠ Carefully check that the insulation is tight, in order to prevent the making and dripping of condensate.

- ⚠ The motorized valve can be omitted, inside the unit, if there is a motorized valve in the distribution manifold of the system and connected to the regulation card of the unit.
- ⚠ 2-way or 3-way motorized valves are available as accessories, see chapter "Compatible accessories" [p. 11](#).
- ⚠ For detailed information on accessories please refer to the "Configuration accessories" [p. 29](#) section.

4.12.4 Shut-off valves

Normally, unit comes without any shut-off valve.

- ⚠ The 2-way and 3-way motorized valves are mandatory for the correct operation of the unit.

4.13 Condensation drain preparation

4.13.1 Preliminary warnings

- ⚠ This appliance is complete with a tray for collecting the condensation produced during operation, which must be channelled to a suitable place for drainage.
- ⚠ Use the installation template to properly position the condensate drain pipe inlet flush with the wall. See chapter Installation template.
- ⚠ The hole for the condensation pipe must always slope towards the outside.
- ⚠ When connecting the condensate drain hose take great care to avoid crushing of the rubber hoses.
- ⚠ In case the fancoil unit is used for heating only, condensate drainage is not necessary. In this case close the drain.

If using a jug for collecting the condensation:

- ⚠ Avoid the hermetic closure of the container.
- ⚠ Prevent the end of the drainage tube from falling below the water level.

If draining into the sewage system:

- ⚠ Make a siphon to prevent bad smells returning up the pipe towards the room. The curve of the siphon must be lower than the condensation collection pan.
- ⚠ The syphon must feature a plug in its lower part or must otherwise allow for a quick disassembly for cleaning purposes.
- ⚠ Install a pump if the drain pipe is higher than lower level of pan.
- ⚠ For vertical installations, the pump must be installed under the side drain pan.
- ⚠ For horizontal installations, the pump should be installed according to specific requirements.

If using an open drain:

- ⚠ Drain the condensate liquid flow directly onto a gutter or into a "white water" drain
- ⚠ If the condensation is not collected, it will be deposited on the support surface. The water could freeze if the outdo-or temperatures are below zero, thus creating a hazard. In this case, appropriate barriers should be installed in order to prevent people from approaching the area.

4.13.2 Condensate drain dimensions

Models	m.u.	200	400	600	800	1000
Condensate drain connection	mm	14	14	14	14	14

4.13.3 Connection for vertical installations

1. Drop-break extension
2. Condensate drain connection
3. Liquid drain pipe

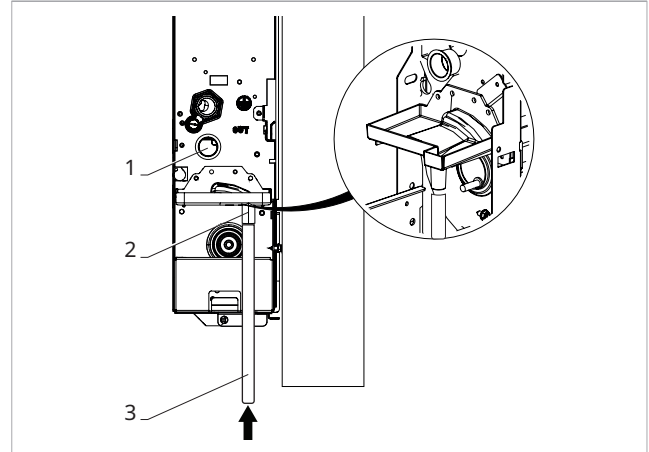

- Connect the condensate drain pipe to the condensate drain connection
- direct the liquid drain pipe towards a suitable location for drainage
- keep a minimum slope of 3% towards the drain location
- insulate fitting points

- ⚠ Check that the drop-break extension is present and properly installed.

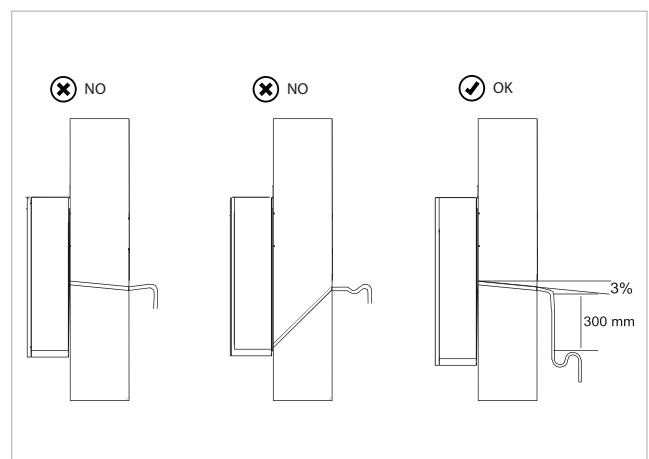

- ⚠ Pay attention to the tilt of the condensate drain pipe.
- ⚠ Use plastic drainage pipes.
- ⚠ Avoid pipes made of metallic material.
- ⚠ Make sure all joints are sealed to prevent leakage of water.
- ⚠ Condensate drainage pipes must be insulated for both indoor and outdoor sections of the house to avoid condensation on the surface and/or freezing problems.
- ⚠ When mounting the pump, for vertical installations, the pump should be mounted under the side drain pan.

4.13.4 Connection for horizontal installations

⚠ Horizontal installation is only possible for horizontal SL versions.

1. Condensate drain tray
2. Condensate drain connection
3. Adapter connection
4. Copper pipe

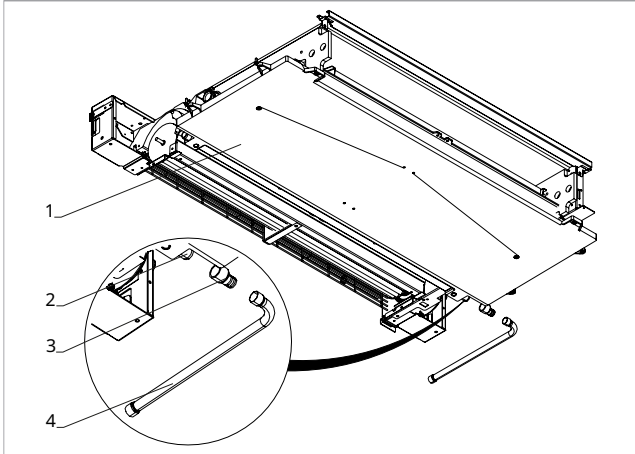

- Connect the adapter fitting to the condensate drain connection
- Connect the copper pipe to the adapter fitting

1. Liquid drain pipe

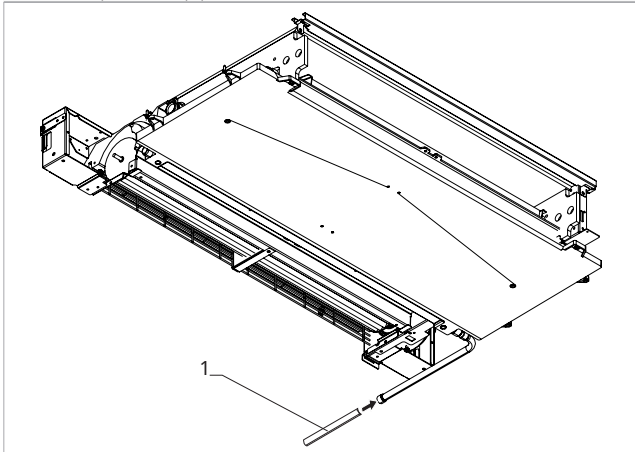

- connect the condensate drain pipe to the copper pipe
- direct the liquid drain pipe towards a suitable location for drainage
- keep a minimum slope of 3% towards the drain location
- insulate fitting points

⚠ Condensate drainage pipes must be insulated for both indoor and outdoor sections of the house to avoid condensation on the surface and/or freezing problems. The insulation must be fitted until the condensate drain pipe is plugged into the connection provided on the unit.

⚠ Avoid counter-slope sections.

1. Unit

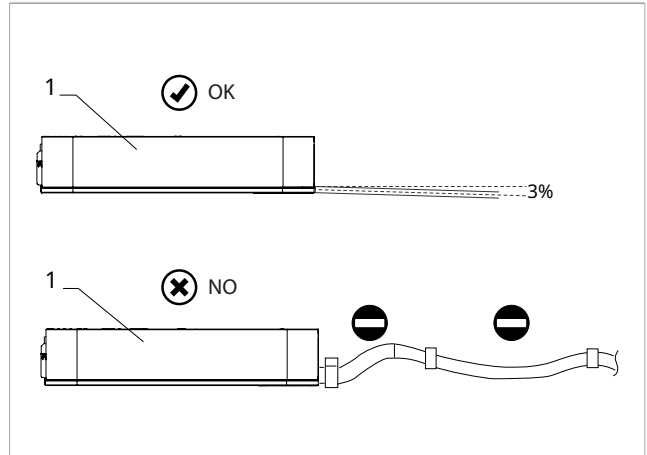

4.13.5 Check

Make sure that:

- the unit is installed perfectly level, or with a slight slope in the direction of condensate drainage
- The condensate drain pipe has been properly insulated to the inlet of the unit, so as to prevent condensate drips outside the drip pan itself

After the installation is completed:

- pour the water very slowly into the condensate drain pan
- check the right outflow

4.14 Filling the system

⚠ When starting the system, make sure the lockshield on the hydraulic unit is open.

⚠ If there is a power failure and the thermostatic head has been powered before, it will be necessary to use the appropriate cap to press the valve shutter to open it.

- A** Vertical installation
- B** Horizontal installation

- 1.** Coil vent

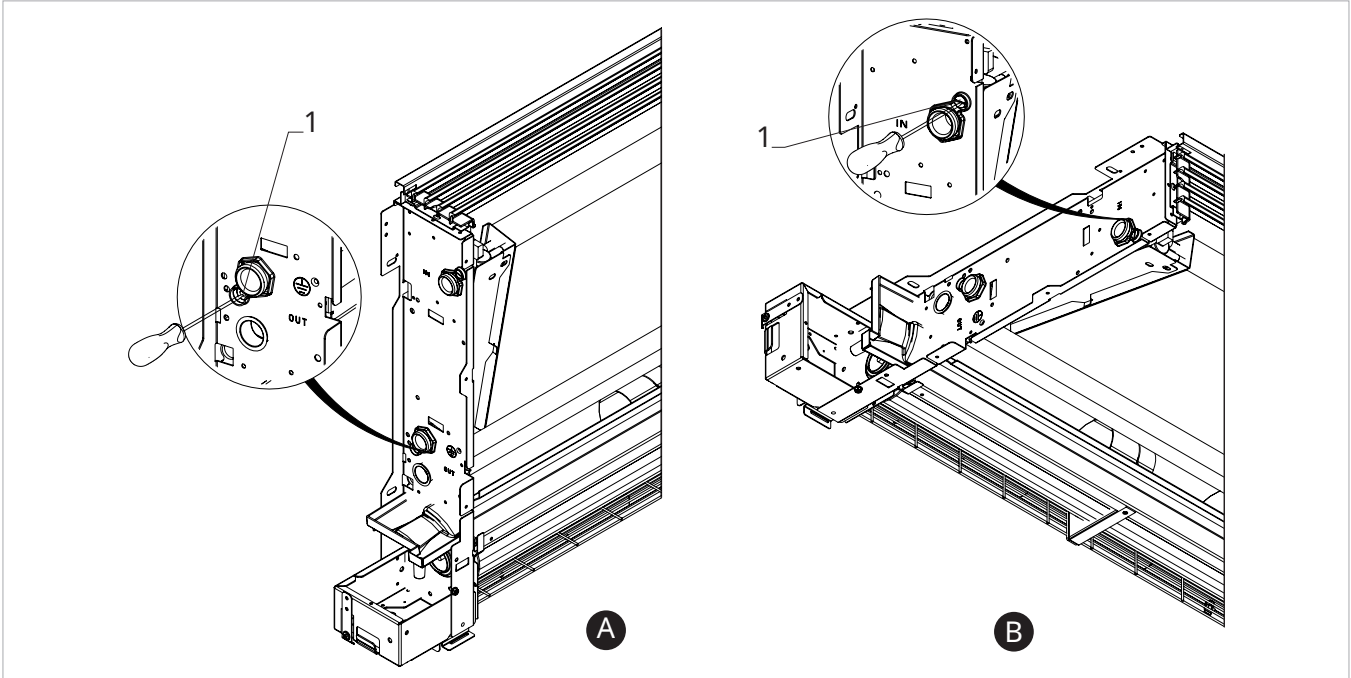

To fill the system:

- open the vent valves
- open all the system's shut-off devices
- slowly open the water tap

⚠ For vertically installed models, act, using a screwdriver, on the battery vent located higher up.

⚠ For models installed in the horizontal position, act, using a screwdriver, on the battery vent located lower down.

When water begins to leak out of the breather valves:

- close the vent valves
- complete system filling
- verify that you have reached the nominal pressure for the system
- close the water tap
- check the tightness of the gaskets

⚠ It is recommended to repeat this operation after the device has been running for a few hours.

⚠ Regularly check the system's pressure.

4.14.1 Mounting the thermostatic head

To mount the thermostatic head:

- tighten the head to the valve body

To facilitate the system mounting, filling and venting operations, even without electric power, the thermostatic head is supplied with a tool that keep it open.

⚠ Remove the tool from the thermostatic head before starting the system.

- 1.** Thermostatic head
- 2.** Valve body
- 3.** red plastic tool

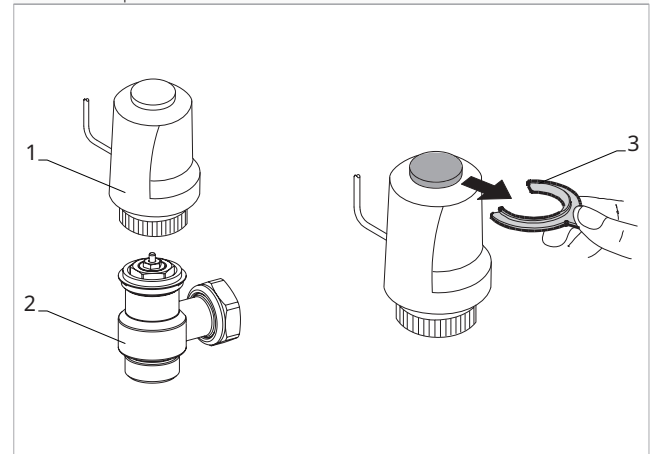

4.15 Electric connections

The device leaves the factory fully wired up and needs only the connection to the power supply, to any controls and accessories.

4.15.1 Preliminary warnings

- ⚠ All operations of an electrical nature must be carried out by qualified personnel having the necessary legal requirements, trained and informed about the risks related to such operations.
- ⚠ All connections must be made following the regulations in force in the country of installation.
- ⚠ Before carrying out any work, make sure that the power supply is switched off.
- ⚠ The unit must only be powered after all plumbing and electrical work has been completed.

Make sure that:

- the characteristics of the electric network are adapted to the absorption of the apparatus, considering also any other devices in parallel operation
- the power supply voltage and system frequency match to the values indicated on the device's plate data

- the cables must be appropriate for the type of installation in accordance with the applicable IEC standards
- the power supply is provide with protection against overload and/or short-circuit

It is required:

- connect the device an efficient ground connection
- the use of a dedicated main switch fitted with time-delay fuse or with an automatic circuit breaker switch, installed near the device
- ⚠ The device is equipped with suppression filter as laid down by the applicable laws and standards. Use selective circuit breakers to compensate for the micro-dispersion on the ground of this device.
- ⊖ It is forbidden the use of gas and water pipes for grounding the appliance.
- ⚠ If you need to replace the power cable, contact only qualified staff and in compliance with the applicable national laws.
- ⚠ Disconnect the main circuit breaker before making any electrical connections and performing maintenance on the equipment.

4.15.2 Power line dimensioning

For the size of the power supply cable and safety devices, use the following table.

Models	m.u.	200	400	600	800	1000
Power conductor (phase+neutral)	mm ²	1,5	1,5	1,5	1,5	1,5
protective conductor section on ground	mm ²	1,5	1,5	1,5	1,5	1,5
Circuit breaker	A	2	2	2	2	2

4.15.3 Access to the terminal block

- 1. Fixing screws
- 2. Cover of the electrical box

- 3. Terminal block for wiring

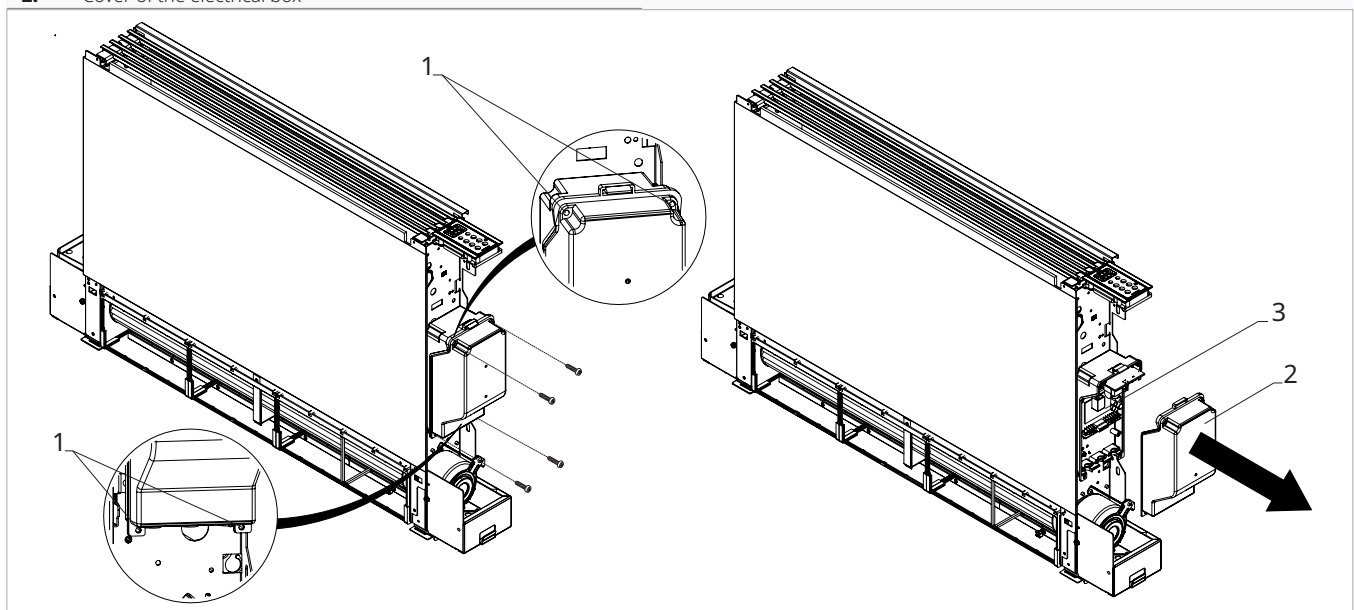

- ⚠ Before doing any work, make sure that the supply power is disconnect.

- ⚠ Access to the electrical panel is only permitted to qualified personnel.

To access:

- if installed, remove the movable cover panel
- Disconnect the on-board display connector (if present)

To access the connections:

- unscrew the fixing screws of the electric box
- remove the lid from the junction box

- ⚠ Refer to the information in the wiring diagram of the unit you are installing.
- ⚠ The electrical connection can be made by a cable recessed into the wall as indicated on the installation template (connection recommended for installation of the device at the top of the wall).
- ⚠ It is necessary to check that the power supply is provided with appropriate protection against electric shorts and/or overloads
- ⚠ Refer to the installation manual of the control to make the connection of the control.

4.15.4 Power supply connection

Accompanying material

Accompanying the unit, contained in a bag placed on the cover of the electrical box, are:

- 1 terminal for power supply connection (L-N)
- cable gland
- 1 terminal for serial connection (-BA+)
- screws

Connection

1. Terminal block for wiring
2. Power supply cables
3. Quick-connect terminal
4. Earth connection

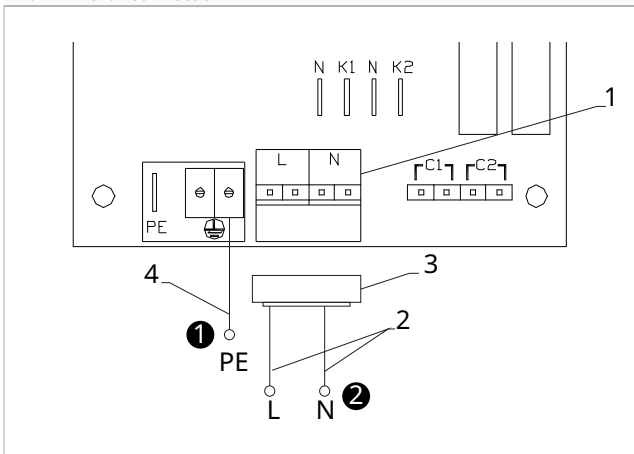

To make the connections:

- use the supplied quick terminal
- connect phase and neutral (L-N) to the quick terminal
- connect the quick-connect terminal to the terminal block
- Connect the ground wire (PE) to the terminal provided on the electrical panel

- ⚠ Refer to the installation manual of the control to make the connection of the control.

1. Cable gland

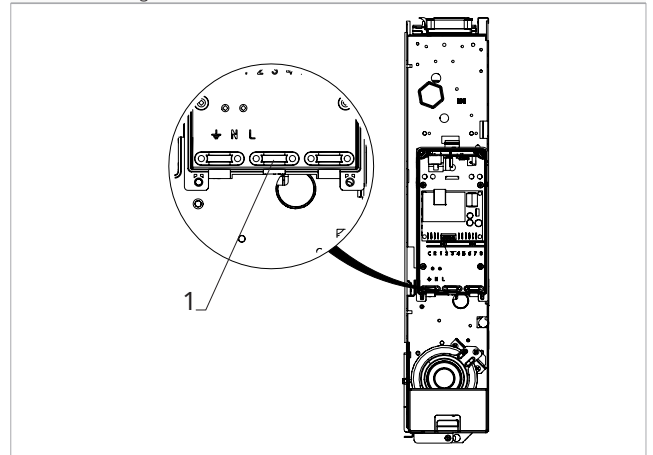

For fixing cables:

- use the cable glands provided
- fix the cables

MAINTENANCE

Routine maintenance is essential to keep the device always efficient, safe and reliable over time.

5.1 Preliminary warnings

⚠ This section is dedicated to the Technical Service Assistance. The features of the Technical Service Assistance are described in chapter "Recipients" p. 6.

⚠ For detailed information on accessories please refer to the "Configuration accessories" p. 29 section.

⚠ This unit contains fluorinated greenhouse gases covered by the Kyoto Protocol. Maintenance and disposal operations must be carried out by qualified personnel only.

Before each cleaning and maintenance intervention:

- disconnect the device from the power mains by turning the system master switch to "OFF"
- wait for the components to cool down in order to avoid any burns

⊖ Carrying out any technical or cleaning work before disconnecting the unit from the power supply is forbidden.

⚠ Make sure that there is no voltage before operating.

⚠ After completing the maintenance work, must be restored the original condition.

⚠ Warnings:

- Do not lean or sit on the fancoil to avoid damaging the appliance.
- Do not manually move the horizontal louver of the air outlet. Always use the remote control to do this operation.
- If water leaks from the device, you must switch it off immediately and disconnect the power supply. Then, call the nearest customer service centre.
- The device must not be installed in rooms where there are explosive gases or where there are conditions of humidity and temperature out of the limits defined in the installation manual.
- Clean the filter regularly.

5.2 Routine maintenance

The routine maintenance plan includes the following cleaning operations.

Carry out cleaning:

- every six months

Before each cleaning and maintenance intervention:

- disconnect the appliance from the mains
- set the plant master switch in the OFF position.

⚠ Wait for the components to cool down in order to avoid any burns.

⚠ After completing the maintenance work, must be restored the original condition.

⊖ It is forbidden to open the access doors and carry out any technical or cleaning intervention, before having disconnect the device from the mains supply by placing the main switch of the system on "OFF".

5.2.1 External cleaning

Clean the external surfaces using a soft cloth dampened with water.

⚠ Do not use abrasive sponges or abrasive or corrosive detergents as you might damage the painted surface.

⚠ Disconnect the unit from the power supply before each cleaning and maintenance intervention by setting the main power supply switch to off.

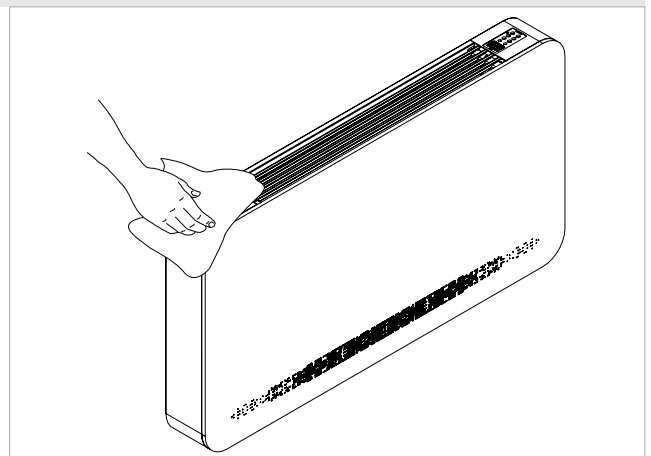

5.2.2 Air intake filter cleaning

Cleaning the filter must be carried out:

- after prolonged operation, considered the concentration of impurities in the air

- when you plan to restart the system after prolonged disuse

- 1. Cover cabinet
- 2. Air intake filter

- 3. Plastic tabs

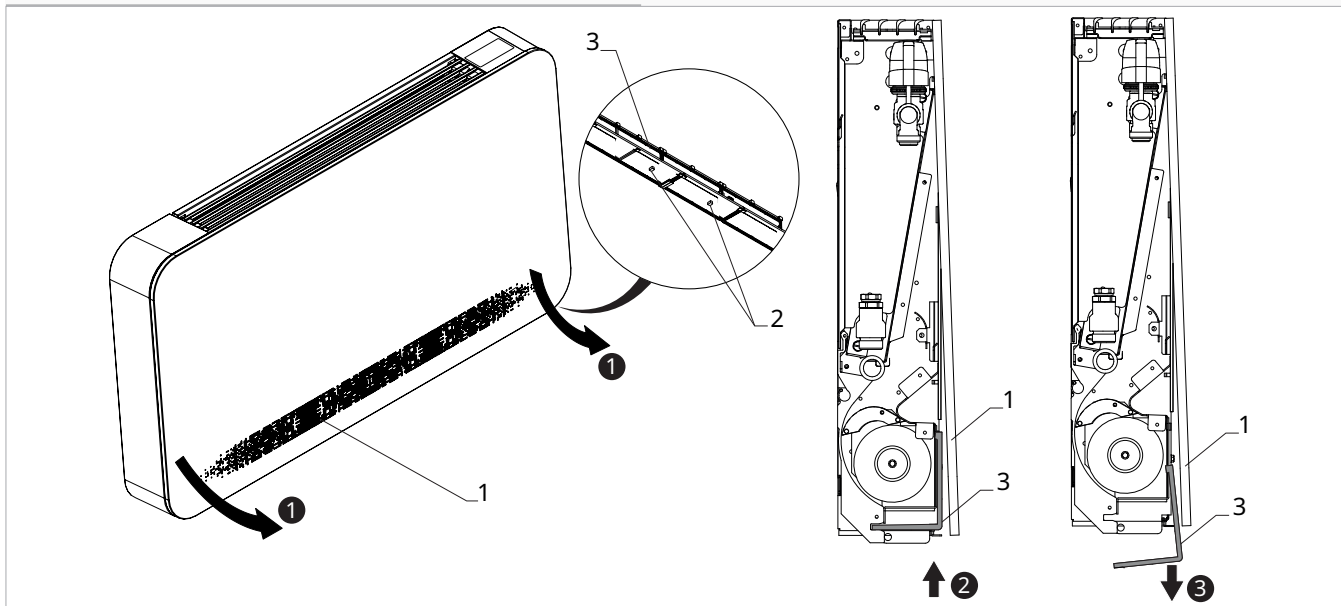

To remove the filter:

- Distance the bottom of the cover cabinet by pulling it toward you
- Push up the plastic tabs on the bottom of the filter
- Unhook the filter from its housing
- remove the filter by pulling it downwards

To reassemble the filter:

- proceed in reverse order

⚠ Check that the filter is fitted correctly.

⊘ It is forbidden to use the device without its mesh filter.

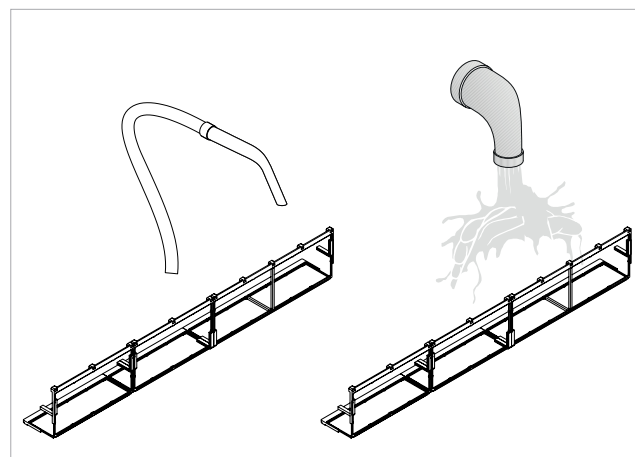

To clean the filters:

- use a vacuum cleaner
- aspirate dust
- wash the filter with running water
- allow it dry

5.3 Suggestions for energy saving

For a correct operation of the device and a great energy saving:

- keep the filters clean
- keep the doors and windows of the locations fitted with air conditioning systems closed as much as possible
- During summer limit the entry of direct sun rays into the rooms to be air-conditioned by means of external screens (projections, curtains, shutters, etc.)

TROUBLESHOOTING

6.1 Preliminary warnings

⚠ For detailed information on accessories please refer to the "Configuration accessories" p. 29 section.

Should you encounter any of the anomalies below:

- the ventilation does not start even if the water circuit is filled with hot or cold water
- the device is losing water in heating mode
- the device is losing water in cooling mode
- the device generates excessive noise
- there is dew on the front panel

Follow the instructions below:

- disconnect the device from power supply immediately
- close the water taps
- contact immediately an authorized technical support center or qualified staff

⚠ The interventions must be carried out by a qualified installer or by a specialized support center.

⊖ Do not intervene personally.

6.2 Troubleshooting table

Effect	Cause	Solution
The ventilation is delayed with respect to the new temperature or function settings.	The circuit valve requires a certain time to open and therefore to make the hot or cold water circulate inside the device.	Wait 2 or 3 minutes to allow the circuit valve to open.
The device does not activate the ventilation.	Cold or hot water is missing from the system.	Make sure the boiler or the water cooler are on.
The ventilation does not start even if the water circuit is filled with hot or cold water.	The hydraulic valve stays closed.	Demount the body of the valve and check if the water circulation is restored. Check the valve operation feeding it separately to 230 V. If you were to turn on, the problem may be in the electronic control.
	The ventilation motor is jammed or burnt.	Check the motor windings and check if the fan rotates freely.
	The wirings are not correct.	Check the electrical connections.
The device is losing water in heating mode.	Leaks at the hydraulic connections of the system.	Check the leak and tighten the connection.
	Losses in the valve group.	Check the condition of the gaskets.
There is dew on the front panel.	Detached thermal insulation.	Check the correct positioning of the thermal and acoustic insulations paying particular attention to the front one located on top of the finned coil.
There are water drops on the air vent.	High humidity conditions (>60%) might generate condensation, especially at minimum ventilation speeds.	As soon as the level of relative humidity drops, the phenomena disappears. However, a few water drops falling inside the device will not cause any malfunction.
The device is losing water in cooling mode.	The condensate tray is clogged.	Slowly pour a bottle of water in the lower section of the battery to check the drainage; if necessary clean the tray and/or improve the slope of the drain pipe.
	The condensate discharge pipe does not have the slope required for correct drainage.	
	The connection pipes and the valves unit are not well insulated.	Check the pipe insulation.
The device generates excessive noise.	The fan touches the structure.	Verify
	The fan is unbalanced.	The unbalancing generates excessive machine vibrations: replace the fan.
	Check the filters for dirt and clean them if necessary	Clean filters

CONFIGURATION ACCESSORIES

7.1 Shut-off valves

Normally, unit comes without any shut-off valve.

⚠ The 2-way and 3-way motorized valves are mandatory for the correct operation of the unit.

⚠ The motorized valve can be omitted, inside the unit, if there is a motorized valve in the distribution manifold of the system and connected to the regulation card of the unit.

⚠ Refer to the "Compatible accessories" [p. 11](#) chapter to locate the accessory.

7.1.1 Connection with manual 2-way valve

2 way valve group with manual closure

In case of choice for the 2-way manual valve:

- no electrical connection are necessary
- connect to the flow at the bottom

Connection with pipes from the floor

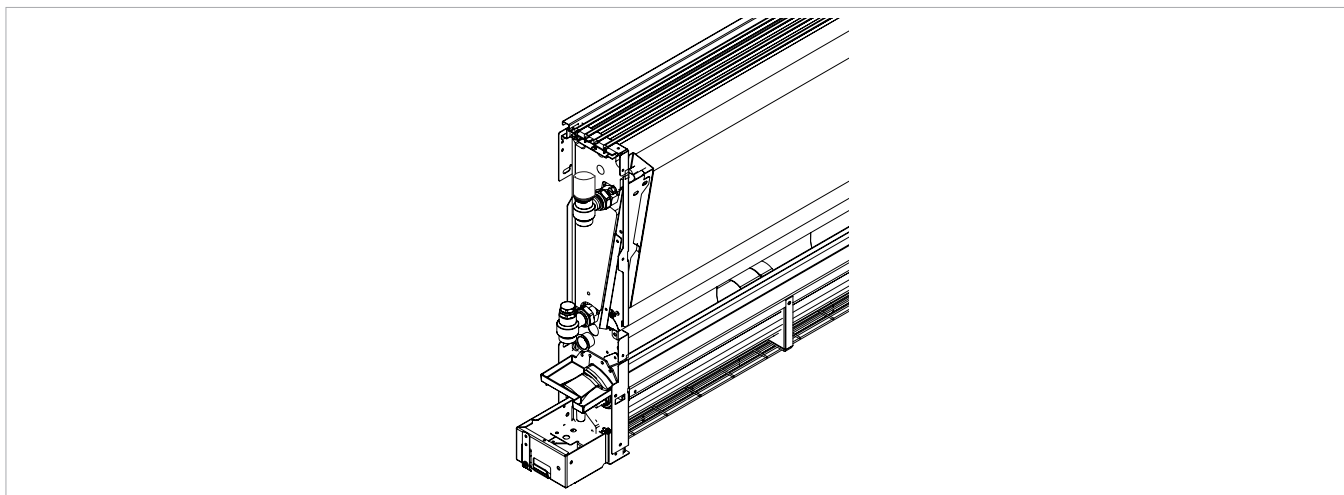

Connection with pipes coming from the wall

⚠ The addition of the Eurokonus 90° L-fitting kit is required to connect the valves with the pipes coming from the parate.

⚠ Refer to the "Compatible accessories" [p. 11](#) chapter to locate the accessory.

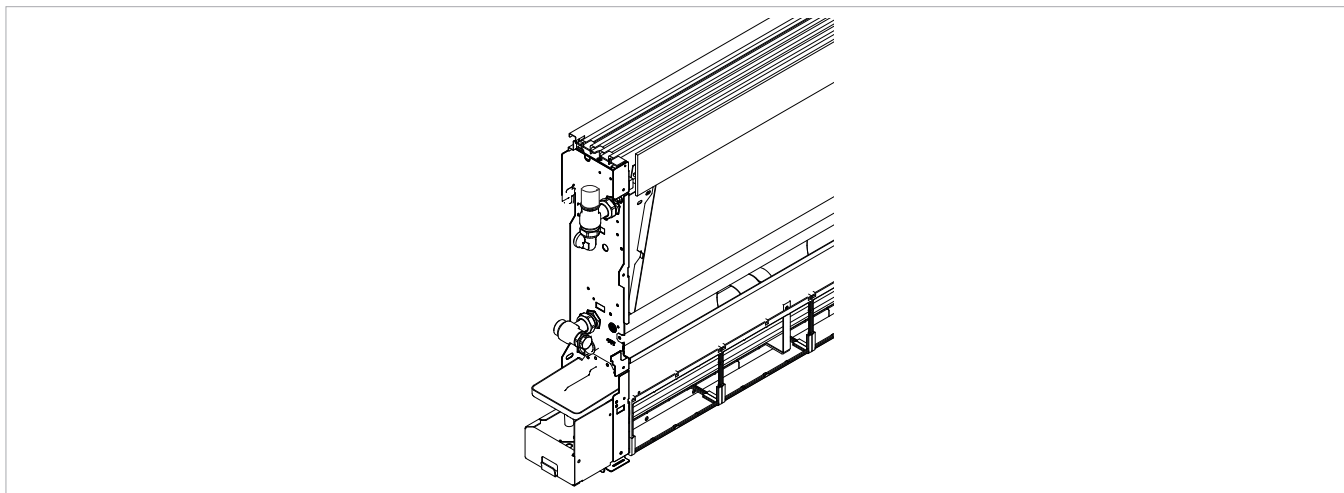

7.1.2 Connection with 2-way valves with thermoelectric motor

2 way valve group (water inlet valve, shut off valve and electro thermal motor)

In case of choice for the 2-way valve and thermoelectric motor:

- electrical connection are required
- connect to the flow at the bottom

Connection with pipes from the wall

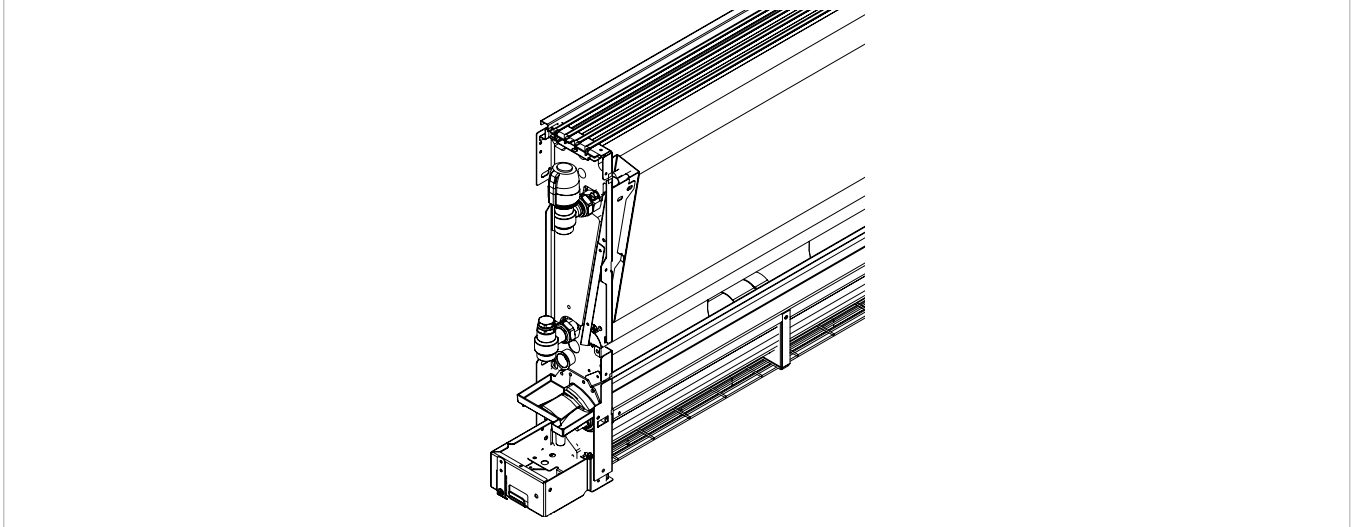

Connection with pipes coming from the wall

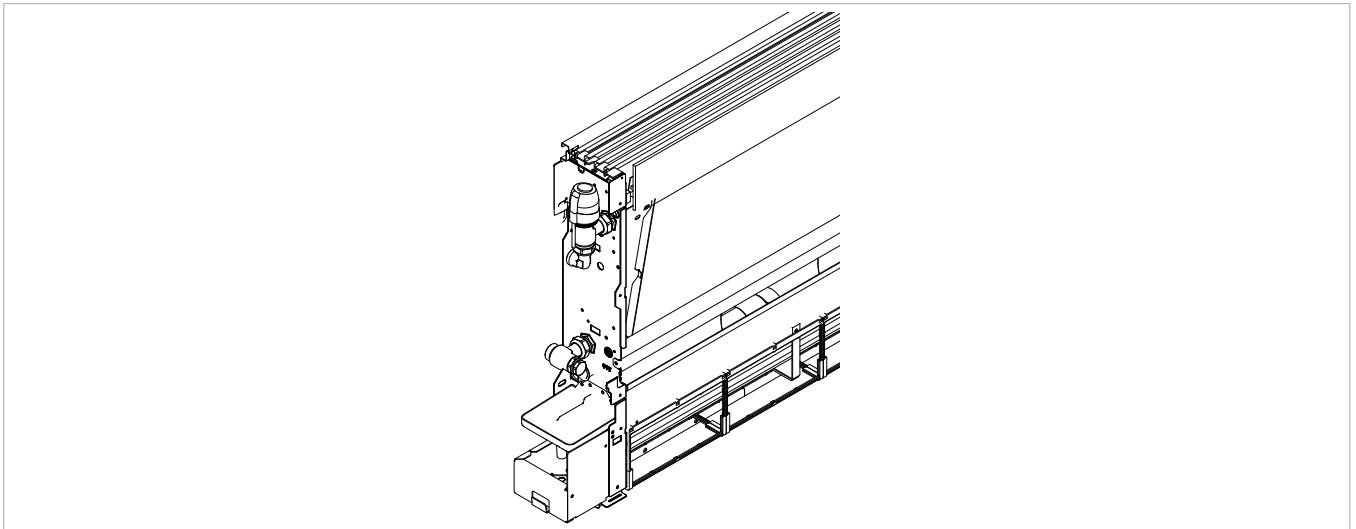

7.1.3 Connection with 3-way diverter valves with thermoelectric motor

3-way diverter valve group with thermoelectric motor (complete with 3-way inlet valve and lock-shield)
In case of choice for the 3-way diverter valve unit with thermoelectric motor:

- electrical connection are required
- connect to the flow at the bottom

Connection with pipes from the wall

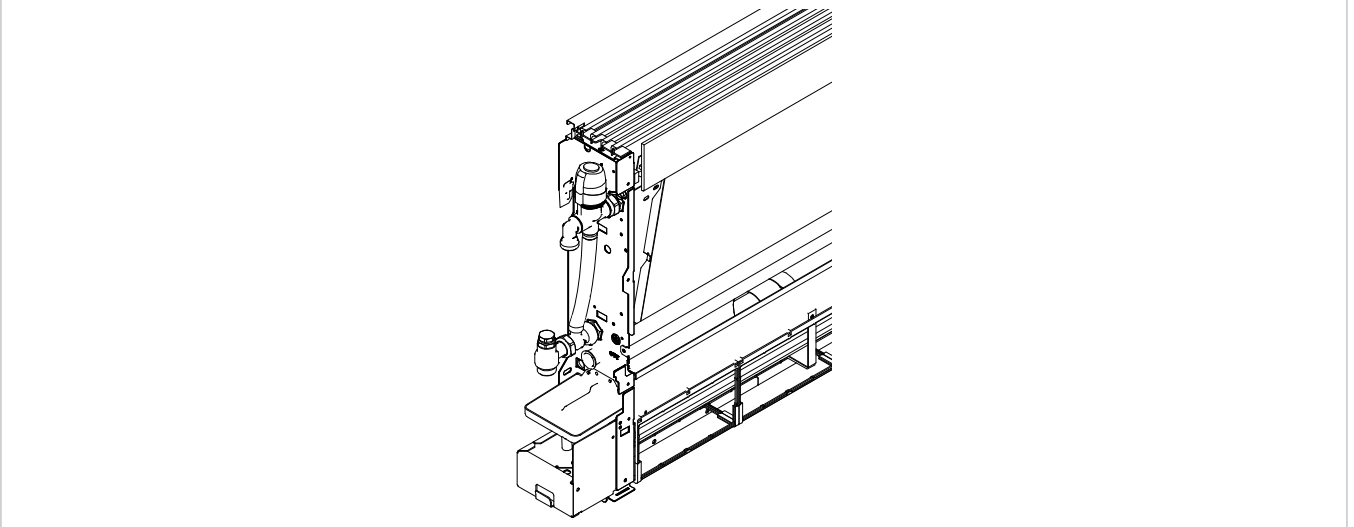

Connection with pipes coming from the wall

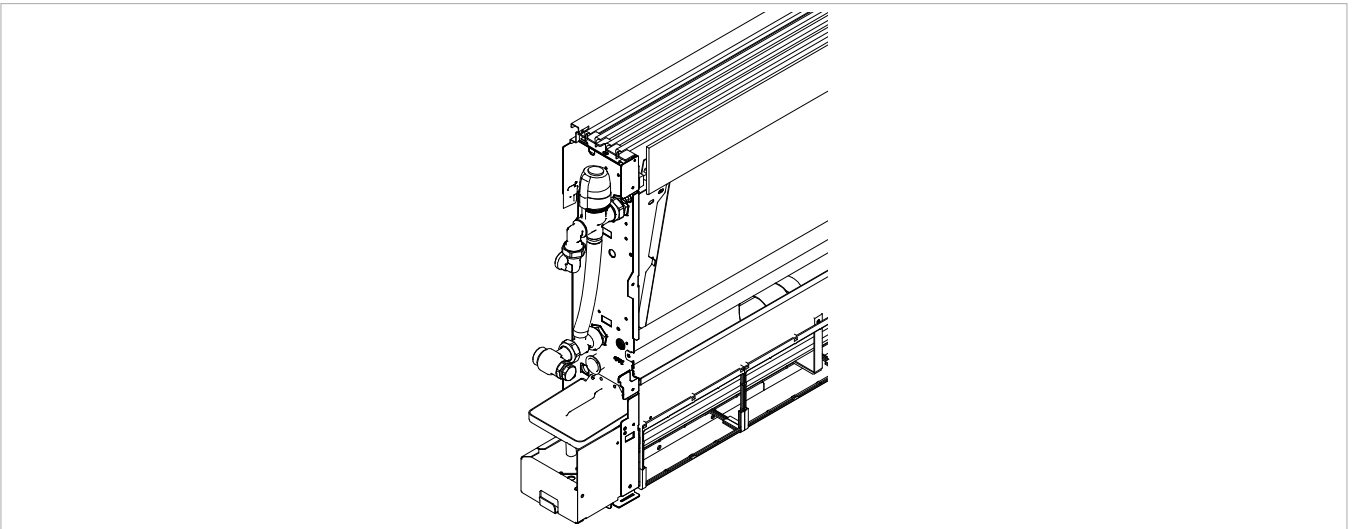

TECHNICAL INFORMATION

8.1 Technical data

Models		m.u.	>OSMO< SL					>OSMO< RS				
			200	400	600	800	1000	200	400	600	800	1000
Cooling performances (W 7/12 °C; A 27 °C) (1)												
Total cooling capacity		kW	0,91	2,12	2,81	3,30	3,71	0,91	2,12	2,81	3,30	3,71
Sensible cooling capacity		kW	0,71	1,54	2,11	2,65	2,90	0,71	1,54	2,11	2,65	2,90
Water flow		L/h	157,00	365,00	483,00	568,00	638,00	157,00	365,00	483,00	568,00	638,00
Pressure drop		kPa	12,10	8,20	17,10	18,00	21,20	12,10	8,20	17,10	18,00	21,20
Heating performances (W 45/40 °C; A 20 °C) (2)												
Heating capacity		kW	1,02	2,21	3,02	3,81	4,32	1,02	2,21	3,02	3,81	4,32
Water flow		L/h	175,00	380,00	519,00	655,00	743,00	175,00	380,00	519,00	655,00	743,00
Pressure drop		kPa	9,10	9,20	19,10	21,20	23,30	9,10	9,20	19,10	21,20	23,30
Hydraulic data												
Coil water content		L	0,47	0,80	1,13	1,46	1,80	0,47	0,80	1,13	1,46	1,80
Maximum operating pressure		bar	10	10	10	10	10	10	10	10	10	10
Hydraulic connections		" EK	3/4	3/4	3/4	3/4	3/4	3/4	3/4	3/4	3/4	3/4
Pipeline diameter		mm	14	14	16	18	20	14	14	16	18	20
Aerualic data												
Maximum air flow		m ³ /h	146	294	438	567	663	146	294	438	567	663
Medium air flow		m ³ /h	90	210	318	410	479	90	210	318	410	479
Minimum flow rate		m ³ /h	49	118	180	247	262	49	118	180	247	262
Static pressure available		Pa	10	10	13	13	13	10	10	13	13	13
Electrical data												
Power consumption at the maximum speed		W	11,0	19,0	20,0	29,0	33,0	11,0	19,0	20,0	29,0	33,0
Power consumption at the minimum speed		W	4,0	4,0	5,0	5,0	6,0	4,0	4,0	5,0	5,0	6,0
Maximum absorbed current		A	0,11	0,16	0,18	0,26	0,28	0,11	0,16	0,18	0,26	0,28
Power supply		V/ph/Hz	230/1/50	230/1/50	230/1/50	230/1/50	230/1/50	230/1/50	230/1/50	230/1/50	230/1/50	230/1/50
Sound data												
Maximum sound power level		dB(A)	51	53	54	55	57	51	53	54	55	57
Sound pressure level at maximum air flow		dB(A)	41	42	44	46	47	41	42	44	46	47
Sound pressure level at medium air flow		dB(A)	33	34	34	35	38	33	34	34	35	38
Sound pressure level at minimum air flow		dB(A)	24	25	26	26	28	24	25	26	26	28
1. Water temperature in coil inlet 7 °C, Water temperature in coil outlet 12 °C, Room air temperature 27 °C b.s. and 19 °C b.u. (according to EN 1397) - maximum speed and head 0 Pa 2. Water temperature in coil inlet 45 °C, Water temperature at coil outlet 40 °C, Room air temperature 20 °C b.s. and 15 °C b.u. (according to EN 1397) - maximum speed and head 0 Pa												

8.2 Dimensions

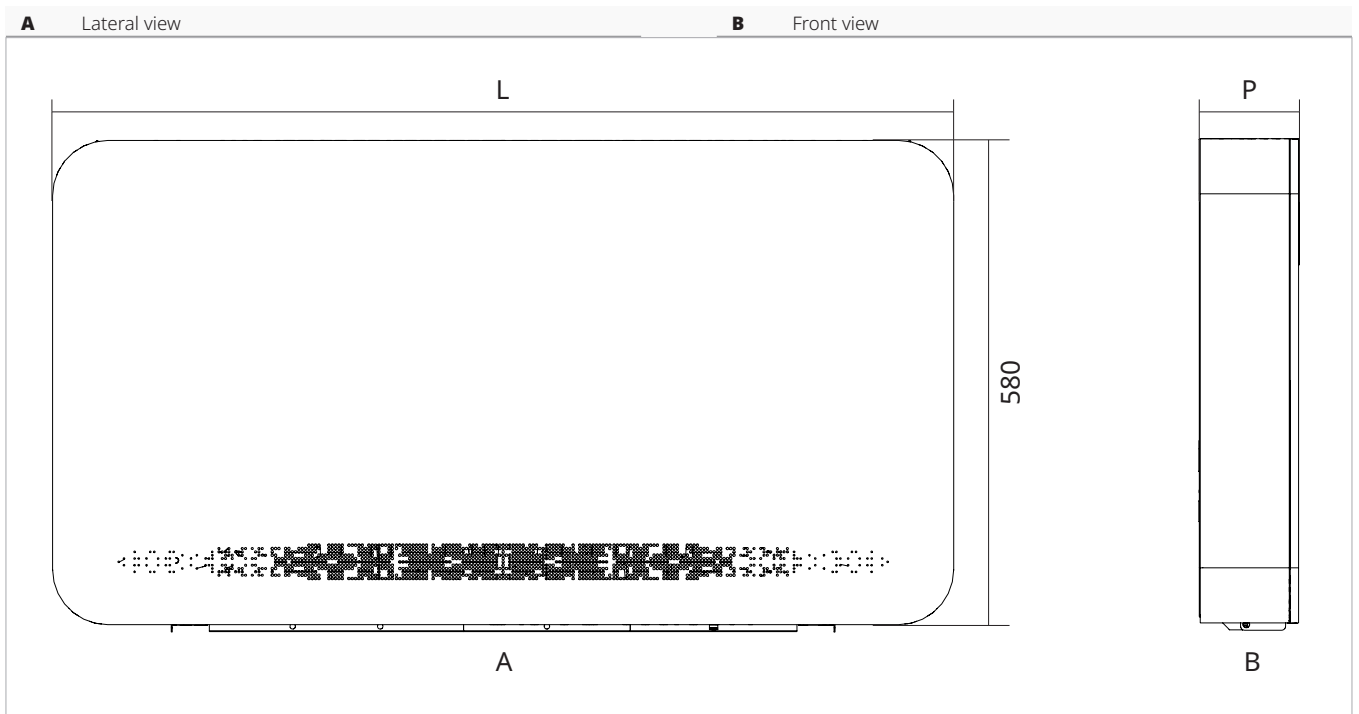

Models	m.u.	>OSMO< SL					>OSMO< RS				
		200	400	600	800	1000	200	400	600	800	1000
Product dimensions and weight											
Width	mm	680	880	1080	1280	1480	680	880	1080	1280	1480
Height	mm	580	580	580	580	580	580	580	580	580	580
Total depth	mm	119	119	119	119	119	129	129	129	129	129
Net weight	kg	13,0	16,0	18,0	20,0	23,0	13,0	16,0	18,0	20,0	23,0

⚠ For >OSMO< SL horizontal installation models, the depth is 129 mm.

8.3 Installation template

⚠ The units are supplied with a paper template for marking the holes necessary for installation.

- | | |
|---|---|
| <ul style="list-style-type: none"> 1. Holes for dowels, \varnothing 8 mm 2. Upper edge of the device 65 mm from the upper edge of the template 3. Inlet position for installation with 3-way valve (with 90° elbow) 4. Inlet position for installation with 2-way valve (with 90° elbow) 5. Outlet with 2-way valves for right connections 6. Outlet with 3-way valves for right connections 7. Electrical connection area 8. \varnothing8 holes for wall fixing dowels | <ul style="list-style-type: none"> 9. Condensate drain for hydraulic connections on the right 10. External perimeter of the device 11. Place flush with the floor 12. Space prepared for pipe passage for right-hand connections 13. Space prepared for the passage of pipes 14. Condensate drain 15. Electrical connection area for plumbing connections on the right 16. Outlet with 3-way valve 17. Outlet with 2-way valve |
|---|---|

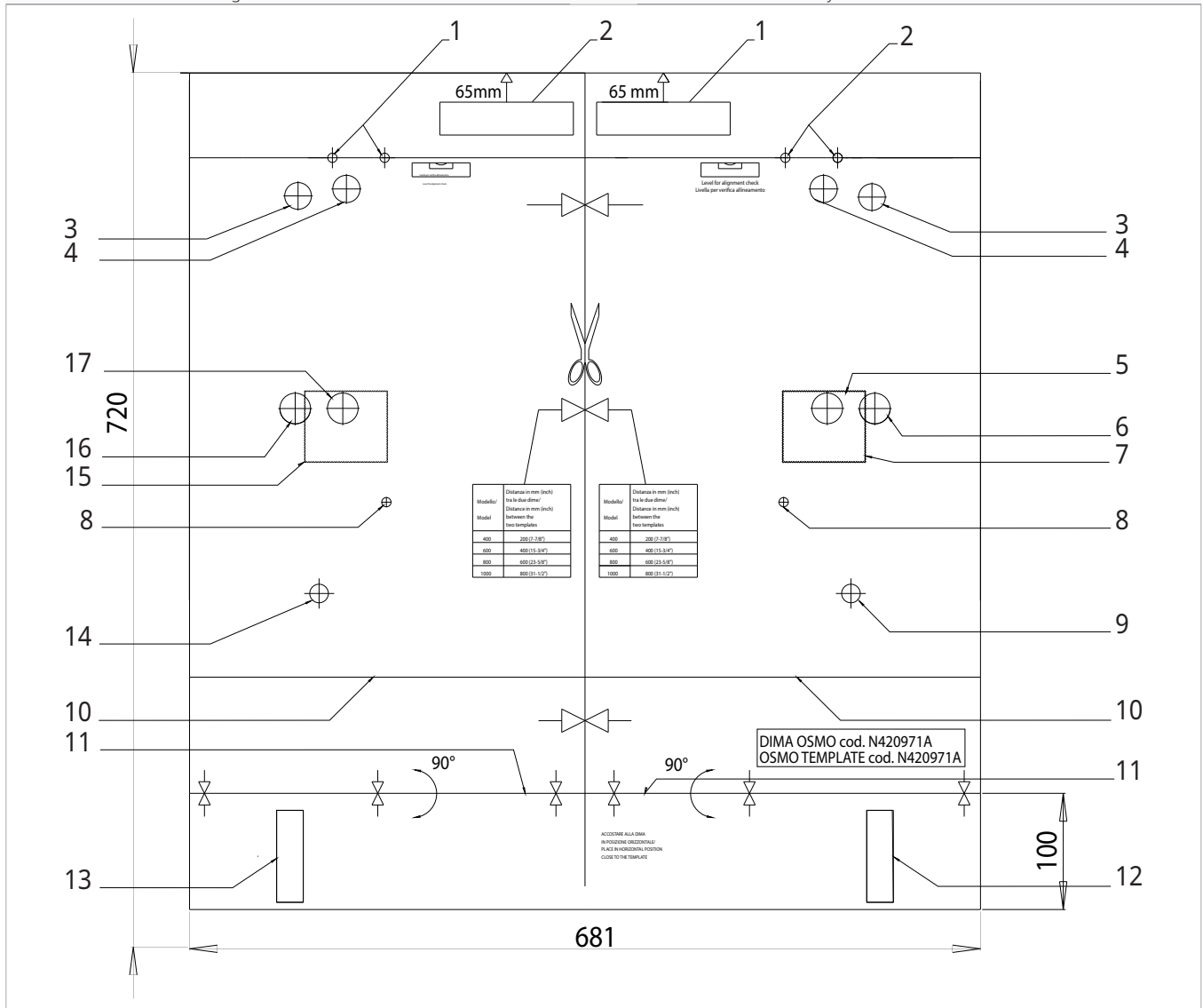



innova

INNOVA S.r.l.
Via I Maggio 8 - 38089 Storo (TN) - ITALY
tel. +39.0465.670104 - fax +39.0465.674965
info@innovaenergie.com