

Installation Manual
(Translation of original
instructions)

EN



N420932A - Rev. 01 - 04/2024

3in1 Mono

5 M - 7 M

First of all, we would like to thank you for having chosen a device of our production.

We are sure you will be happy with it because it represents the state of the art in the technology of home air conditioning.

By following the suggestions contained in this manual, the product you have purchased will operate without problems giving you optimum room temperatures with minimum energy costs.

INNOVA S.r.l.

Conformity

This unit complies with the European directives:

- EN 60335-2-40 Household and similar electrical appliances - Safety Part 2-40: Particular requirements for electrical heat pumps, air-conditioners and dehumidifiers
- Low Voltage Directive 2014/35/UE
- EMC Directive 2014/30/EU on Electromagnetic Compatibility
- RoHS2 Directive 2011/65/EU2 on the restriction of the use of hazardous substances in electrical and electronic equipment
- Directive 2012/96/EC (WEEE) on waste electrical and electronic equipment
- ErP Directive 2009/125/EC and Regulation 2012/206/EC
- F-Gas Regulation 2014/517/EU on fluorinated greenhouse gases
- Directive 2014/68/EU PED on pressure equipment And subsequent amendments.

Markings



TABLE OF CONTENTS

1	General information	<u>p. 6</u>
1.1	About the manual	<u>p. 6</u>
1.1.1	Editorial pictograms	<u>p. 6</u>
1.1.2	Pictograms on the product	<u>p. 6</u>
1.1.3	Recipients	<u>p. 6</u>
1.1.4	Manual organisation	<u>p. 7</u>
1.2	General warnings	<u>p. 7</u>
1.2.1	Specific warnings for R32	<u>p. 8</u>
1.3	Basic rules of security	<u>p. 8</u>
1.3.1	Specific safety rules for R32	<u>p. 8</u>
1.4	Disposal	<u>p. 8</u>
2	Product presentation	<u>p. 9</u>
2.1	Identification	<u>p. 9</u>
2.2	Destination of use	<u>p. 10</u>
2.3	Description of the appliance	<u>p. 10</u>
2.3.1	Square ducting	<u>p. 10</u>
2.3.2	Circular ducting	<u>p. 11</u>
2.4	Configurations	<u>p. 12</u>
2.4.1	SV - Version with vertical coupling	<u>p. 12</u>
2.4.2	SH - Version with horizontal coupling	<u>p. 12</u>
2.4.3	S - Single version	<u>p. 13</u>
2.5	List of external components	<u>p. 13</u>
2.5.1	Heat pump module	<u>p. 13</u>
2.5.2	DHW module	<u>p. 14</u>
2.6	List of internal components	<u>p. 14</u>
2.6.1	Heat pump module	<u>p. 14</u>
2.6.2	DHW module	<u>p. 15</u>
2.7	Compatible accessories	<u>p. 16</u>
3	Installation	<u>p. 18</u>
3.1	Preliminary warnings	<u>p. 18</u>
3.1.1	Preliminary warnings for R32	<u>p. 18</u>
3.2	Reception	<u>p. 18</u>
3.2.1	Preliminary warnings	<u>p. 18</u>
3.2.2	Package description	<u>p. 18</u>
3.3	Dimensions and weights with packaging	<u>p. 19</u>
3.3.1	Heat pump module	<u>p. 19</u>
3.3.2	DHW module	<u>p. 19</u>
3.4	Handling with packaging	<u>p. 19</u>
3.4.1	Preliminary warnings	<u>p. 19</u>
3.4.2	Movement methods	<u>p. 19</u>





3.5 Storage	<u>p. 19</u>
3.5.1 Preliminary warnings	<u>p. 19</u>
3.5.2 Appliance with packaging	<u>p. 20</u>
3.5.3 Appliance without packaging	<u>p. 20</u>
3.6 Unpacking	<u>p. 20</u>
3.6.1 Preliminary warnings	<u>p. 20</u>
3.6.2 Remove the package	<u>p. 21</u>
3.7 Removal of aesthetic panels.	<u>p. 22</u>
3.7.1 Heat pump module	<u>p. 22</u>
3.7.2 DHW module	<u>p. 23</u>
3.8 Handling without packaging	<u>p. 24</u>
3.8.1 Preliminary warnings	<u>p. 24</u>
3.8.2 Movement methods	<u>p. 24</u>
3.9 Installation site	<u>p. 25</u>
3.9.1 Preliminary warnings	<u>p. 25</u>
3.10 Installation minimum distances	<u>p. 26</u>
3.11 predisposition to positioning	<u>p. 27</u>
3.11.1 Aeraulic connection configurations	<u>p. 27</u>
3.11.2 Modification of aeraulic connections	<u>p. 28</u>
3.11.3 Preparation of the wall	<u>p. 29</u>
3.12 Positioning	<u>p. 29</u>
3.12.1 Preliminary warnings	<u>p. 29</u>
3.12.2 Positioning	<u>p. 30</u>
3.13 Aeraulic connections	<u>p. 31</u>
3.13.1 Preliminary warnings	<u>p. 31</u>
3.13.2 Square ducting	<u>p. 31</u>
3.13.3 Circular ducting	<u>p. 32</u>
3.14 Hydraulic connections	<u>p. 33</u>
3.14.1 Preliminary warnings	<u>p. 33</u>
3.14.2 Hydraulic plant	<u>p. 33</u>
3.14.3 Plant water content and minimum flow rate	<u>p. 33</u>
3.14.4 Position and dimensions	<u>p. 34</u>
3.14.5 Connection to the system	<u>p. 35</u>
3.14.6 Filtration system	<u>p. 38</u>
3.14.7 Safety valve	<u>p. 38</u>
3.14.8 Air vent	<u>p. 38</u>
3.15 Filling the plant	<u>p. 38</u>
3.15.1 Preliminary warnings	<u>p. 38</u>
3.15.2 Water quality requirements	<u>p. 38</u>
3.15.3 Filling	<u>p. 39</u>
3.16 Electric connections	<u>p. 39</u>
3.16.1 Preliminary warnings	<u>p. 39</u>
3.16.2 Power line dimensioning	<u>p. 40</u>
3.16.3 Access to the electrical panel	<u>p. 41</u>
3.16.4 Connection	<u>p. 41</u>
3.17 Disassembly and assembly of cosmetic panels after installation	<u>p. 45</u>
3.17.1 Removing covering elements	<u>p. 45</u>
3.17.2 Fitting of covering elements	<u>p. 47</u>

4	Putting it into service	<u>p. 49</u>
4.1	Preliminary warnings.	<u>p. 49</u>
4.1.1	Preliminary warnings for R32.	<u>p. 49</u>
4.2	First start-up.	<u>p. 49</u>
4.2.1	Preliminary checks	<u>p. 49</u>
4.2.2	Water quality checks	<u>p. 50</u>
4.2.3	Powering up	<u>p. 50</u>
4.2.4	Start-up	<u>p. 50</u>
4.2.5	Checks with the machine switched on	<u>p. 50</u>
4.3	Adjustments	<u>p. 51</u>
4.3.1	Setting the head value	<u>p. 51</u>
4.4	PP1 primary circulation pump.	<u>p. 51</u>
4.4.1	Fixed speed mode	<u>p. 51</u>
4.5	Plant delivery	<u>p. 51</u>
4.6	Long period shut-down.	<u>p. 51</u>
4.7	Draining the plant.	<u>p. 52</u>
4.7.1	Preliminary warnings	<u>p. 52</u>
4.7.2	Draining.	<u>p. 52</u>
5	Maintenance	<u>p. 53</u>
5.1	Preliminary warnings.	<u>p. 53</u>
5.1.1	Preliminary warnings for R32.	<u>p. 53</u>
5.2	Once-a-year operations	<u>p. 53</u>
5.2.1	Routine maintenance of the unit	<u>p. 53</u>
5.2.2	Cleaning the net filter	<u>p. 54</u>
5.2.3	Cleaning the air filter	<u>p. 54</u>
5.3	Periodic operations.	<u>p. 54</u>
5.3.1	External cleaning	<u>p. 54</u>
6	Troubleshooting	<u>p. 55</u>
6.1	Preliminary warnings.	<u>p. 55</u>
6.2	Functional aspects not to be interpreted as faults.	<u>p. 55</u>
6.3	Faults reported by the Control Panel.	<u>p. 55</u>
6.4	Troubleshooting Table	<u>p. 56</u>
7	Technical information	<u>p. 58</u>
7.1	Technical data	<u>p. 58</u>
7.2	Operating limits.	<u>p. 60</u>
7.3	Dimensions	<u>p. 62</u>
7.3.1	SV - Version with vertical coupling.	<u>p. 62</u>
7.3.2	SH - Version with horizontal coupling	<u>p. 63</u>
7.3.3	S - Single version	<u>p. 64</u>
7.4	Refrigerator diagram.	<u>p. 65</u>
7.5	PP1 circulation pump graphs	<u>p. 66</u>
7.5.1	Model 5 - 7	<u>p. 66</u>

GENERAL INFORMATION

1.1 About the manual





This manual was written to provide all the explanations for the correct management of the appliance.

-  This instruction manual forms an integral part of the device and therefore must be carefully preserved and must ALWAYS travel with it, even if you transfer the device to another owner or relocate it to other premises. If the manual gets damaged or lost, download a copy from the website.
-  Read this manual carefully before proceeding with any operation and follow the instructions in the individual chapters.
-  The manufacturer is not responsible for damages to persons or property caused by failure to follow the instructions in this manual.
-  This document is restricted in use to the terms of the law and may not be copied or transferred to third parties without the express authorization of the manufacturer.

1.1.1 Editorial pictograms

The pictograms in the next chapter provide the necessary information for correct, safe use of the machine in a rapid, unmistakable way.

Related to security

-  **High risk warning (bold text)**
 - The operation described above presents a risk of serious physical injury, fatality, major damage to the appliance and/or to the environment if not carried out in compliance with safety regulations.
-  Low risk warning (plain text)
 - The operation described above presents a risk of minor physical injury or minor damage to the appliance and/or to the environment if not carried out in compliance with safety regulations.
-  Prohibition (plain text)
 - Refers to prohibited actions.
-  **Important information (bold text)**
 - This indicates important information that must be taken into account during the operations.



In the texts

- procedures
- lists

In the control panels

- actions required
- Expected responses following an action.*

In the figures

- 1 The numbers indicate the individual components.
- A The capital letters indicate component assemblies.
-  The white numbers in black marks indicate a series of actions to be carried out in sequence.
-  The black letter in white identifies an image when there are several images in the same figure.

1.1.2 Pictograms on the product

Symbols are used in some parts of the appliance:

Related to security

-  **Caution: electrical danger**
 - The concerned personnel is informed to the presence of electricity and the risk of suffering an electric shock.

Related to refrigerant R32

-  **Caution: low flammability material**
 - R32 refrigerant gas is slightly flammable and odourless. Avoid proximity to sources of ignition in continuous operation (open flames, gas appliances, electric stoves, lighted cigarettes, etc.).



Instructions

- Read the instructions carefully before performing any work on the appliance.



Instructions for the Technical Service Centre

- The Technical Service Centre must read the instructions carefully before performing any work on the appliance.



Instructions for the user

- Further information can be found in the technical documentation of the appliance.

1.1.3 Recipients

User

Non-expert person capable of operating the product in safe conditions for people, for the product itself and the environment, interpreting an elementary diagnostic of faults and abnormal operating conditions, carrying out simple adjustment, checking and maintenance operations.

Installer

Expert person qualified to position and connect (hydraulically, electrically, etc.) the unit to the plant; this person is responsible for handling and correct installation according to the instructions provided in this manual and the national standards currently in force.

To work on the refrigeration circuit, the installer must comply with the provisions of Regulation 303/2008/EC which

defines, in accordance with Directive 842/2006/EC, the requirements for companies and personnel with regard to fixed refrigeration, air conditioning and heat pump equipment containing certain fluorinated greenhouse gases (F-gas licence).

Technical Service Centre

Expert and qualified person authorised directly by the manufacturer to carry out all routine and supplementary maintenance operations, as well as every adjustment, check, repair and replacement of parts necessary during the life of the unit itself.

Service personnel must comply with the provisions of Regulation 303/2008/EC which defines, in accordance with Directive 842/2006/EC, the requirements for companies and personnel with regard to fixed refrigeration, air conditioning and heat pump equipment containing certain fluorinated greenhouse gases (F-gas licence).

1.1.4 Manual organisation

The manual is divided into sections each dedicated to one or more target groups.

Coding

It addresses all recipients.

It contains the list of products and/or accessories referred to in the manual.

General information

It addresses all recipients.

It contains general information and important warnings that should be known before installing and using the appliance.

Product presentation

It addresses all recipients.

It contains the information to identify the product, its components, compatible accessories and destination of use.

Installation

It is addressed exclusively to the installer.

It contains specific warnings and all the information necessary for positioning, mounting and connecting the appliance.

Commissioning, maintenance and troubleshooting

They are addressed exclusively to the Technical Assistance Centre.

It contains specific warnings useful information for the most common commissioning and routine maintenance.

Technical information

It addresses all recipients.

It contains detailed technical information about the appliance.

1.2 General warnings

- ⚠ Specific warnings are given in each chapter of the document and must be read before starting operations.
- ⚠ All personnel involved must be aware of the operations and dangers that may arise when beginning all unit installation operations.
- ⚠ Installation performed outside the warnings provided in this manual and use of the appliance outside the prescribed temperature limits will invalidate the warranty.
- ⚠ The installation and maintenance of climate control equipment could be dangerous because there is pressurised refrigerant gas and live electrical components inside the appliances. The installation, initial start-up and subsequent maintenance phases must be carried out exclusively by authorised and qualified personnel (see first start-up request form enclosed with the appliance).
- ⚠ Any contractual or extra-contractual liability for damage caused to persons, animals or property, due to installation, adjustment and maintenance errors or improper use is excluded. All uses not expressly indicated in this manual are not permitted.
- ⚠ Only qualified installer companies are authorised to install the device. After having completed installation, the installer will issue a declaration of conformity to the plant manager, as required by the applicable standards and the guidelines provided by contractor's instruction manual supplied with the device.
- ⚠ First start-up and repair or maintenance operations must be carried out by the Technical Assistance Centre or by qualified personnel following the provisions of this manual.
- ⚠ A list of the authorized Technical Service Centers can be found on the website, in the service section.
- ⚠ Do not modify or tamper with the appliance as this can lead to dangerous situations.
- ⚠ Use suitable accident-prevention clothing and equipment during installation and/or maintenance operations. The manufacturer is not liable for the non-observance of the current safety and accident prevention regulations.
- ⚠ In the event of liquid or oil leaks, set the master switch of the plant to "off" and close the water taps. Call the authorised Technical Assistance Centre or professionally qualified personnel as soon as possible and do not work on the appliance yourself.
- ⚠ In case of replacement of parts, use only original parts.
- ⚠ The manufacturer reserves the right to make changes to its models at any time to improve its product, without prejudice to the essential characteristics described in this manual. The manufacturer is not obliged to add such modifications to machines previously manufactured, already delivered or under construction.
- ⚠ The unit can be used by children over the age of 8, and by people with reduced physical, sensory or mental capabilities, or with no experience or necessary knowledge, as long as they are monitored or after they have received instructions on the safe use of the unit and have understood the dangers involved. Children must not play with the appliance. The cleaning and maintenance that must be performed by the user should not be carried out by children without supervision.

1.2.1 Specific warnings for R32

- ⓘ This document contains only some of the warnings related to the refrigerant R32. For more comprehensive information, carefully read the safety data sheet available from the dealer.**
- ⚠** Each chapter contains specific warnings for the operations it describes. These warnings must be read before starting activities.
- ⚠** All precautions concerning the treatment of the refrigerant must be observed following the regulations in force.

- ⚠** The unit uses environmentally friendly R32 refrigerant gas, with a Global Warming Potential (GWP) = 675. Do not release R32 gas into the atmosphere.
- ⚠** R32 refrigerant gas is slightly flammable and odourless.
- ⚠** Do not place flammable objects (spray cans) within 1 metre of the air outlet.
- ⚠** Avoid proximity to sources of ignition in continuous operation (open flames, gas appliances, electric stoves, lighted cigarettes, etc.).
- ⚠** If refrigerant gas escapes, aerate the room abundantly and leave. Call the Technical Assistance Service or professionally qualified personnel as soon as possible and do not intervene on the appliance yourself.

1.3 Basic rules of security

Please keep in mind that the use of products powered by electricity and water call for operators to comply with certain essential safety rules:

- ⊖** The use of the appliance to children and unassisted disabled persons is prohibited.
- ⊖** It is forbidden to touch the device with wet or damp body parts.
- ⊖** It is forbidden to carry out any operation before disconnecting the appliance from the power supply by setting the plant master switch to "off".
- ⊖** It is forbidden to modify the safety or adjustment devices or adjust without authorization and indications of the manufacturer.
- ⊖** It is forbidden to pull, unplug or twist the device's electric cables, even if it is disconnected from the mains.

- ⊖** It is forbidden to introduce objects and substances through the air inlet and outlet grilles.
- ⊖** It is forbidden to open the access doors of the device's internal parts without first having set main switch of the system to "off".
- ⊖** It is forbidden to dispose of, or leave in the reach of children, the packaging materials which could become a source of danger.

1.3.1 Specific safety rules for R32

This document contains only some of the safety rules related to refrigerant R32. For more comprehensive information, carefully read the safety data sheet available from the dealer.

- ⊖** Smoking in the vicinity of the appliance is prohibited.
- ⊖** Using a mobile phone near the appliance is prohibited.
- ⊖** Using leak detectors with halogen lamps is prohibited.

1.4 Disposal



The symbol on the product or its packaging indicates that the product must not be treated as normal household waste, but must be taken to the appropriate collection point for the recycling of electrical and electronic equipment. Proper disposal of this product avoids harm to humans and the environment and promotes the reuse of valuable raw materials.

For more detailed information about the recycling of this product, contact your local city office, your household waste disposal service or the shop where you purchased the product. Illegal disposal of the product by the user involves the application of the administrative sanctions provided for by the regulations in force. This provision is only valid in the EU Member States.

- ⚠** Avoid disassembling the unit yourself.
- ⚠** This unit contains fluorinated greenhouse gases covered by the Kyoto Protocol. Maintenance and disposal operations must be carried out by qualified personnel only.
- ⚠** **Contact an authorised Technical Assistance Centre to disassemble the appliance.**

PRODUCT PRESENTATION

2.1 Identification

The appliance can be identified by the rating plate:

Heat pump module

1. Front panel

2. Technical rating plate

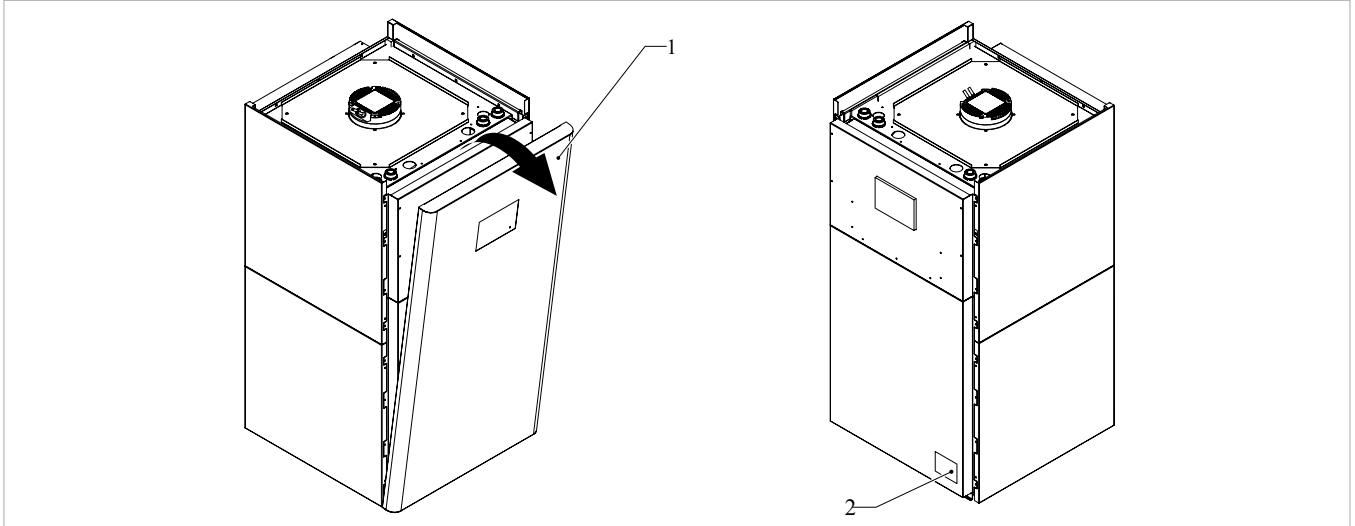

DHW module

1. Technical rating plate

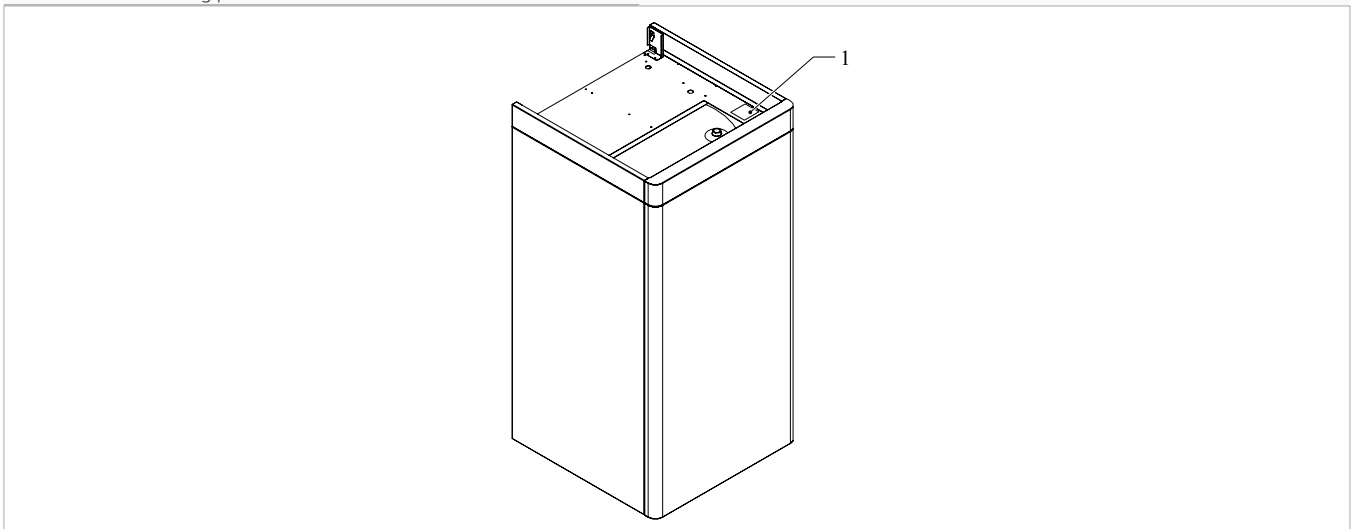

Technical rating plate

This shows the technical and performance specifications of the appliance.

⚠ According to EU Regulation No. 517/2014 concerning certain fluorinated greenhouse gases, it is mandatory to indicate the total amount of refrigerant present in the installed system. This information can be found on the rating plate of the combined outdoor unit.

⚠ Tampering with, removal of, or lack of identification plates will not allow for the safe identification of the product by its serial number and therefore invalidates the warranty.

2.2 Destination of use

These appliances are designed for air-conditioning/heating and/or domestic hot water (DHW) production and must

be intended for this use compatibly with their performance characteristics.

2.3 Description of the appliance

The units are designed for indoor floor installation.

The units are made up of:

- Heat pump module
- DHW module

The is available in three versions based on the type of installation and module combinations:

3in1 Mono SV - Version with vertical coupling

3in1 Mono SH - Version with horizontal coupling

3in1 Mono S - Single version

The units are manufactured in two different sizes according to performance:

Single-phase 5 M - 7 M models

It is possible to configure the air outlet and intake on three sides during installation. As standard, the units are configured with air outlet and intake at the back.

Please refer to chapter "Aeraulic connection configurations" [p. 27](#) for available configurations.

Two modes of ducting are provided:

- Square ducting
- Circular ducting

2.3.1 Square ducting

- | | |
|----|-------------------|
| 1. | Plenum connection |
| 2. | Square silencer |

- | | |
|----|--|
| 3. | Telescopic channel |
| 4. | Aesthetic built-in grilles with plenum |

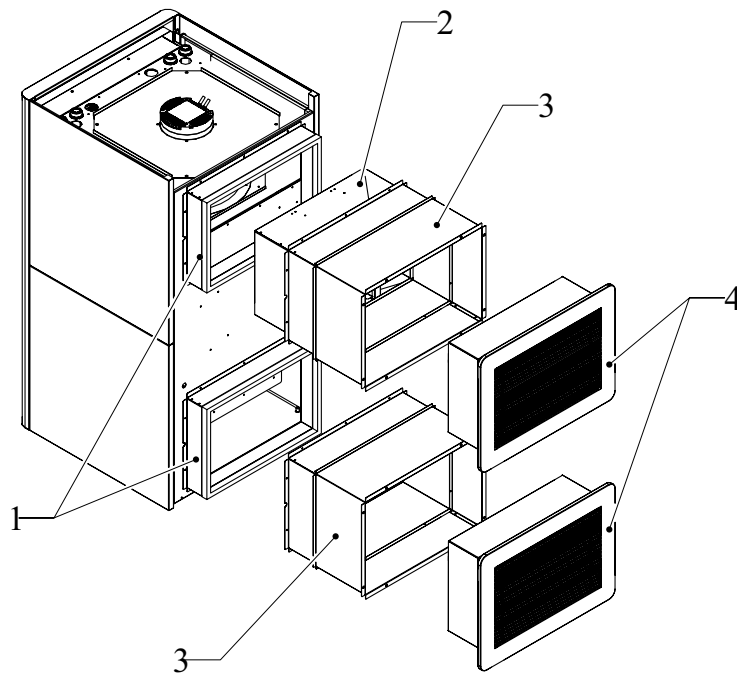

⚠ Please refer to chapter "Compatible accessories" [p. 16](#) for the list of available accessories.

2.3.2 Circular ducting

- | | | | |
|----|--|----|--|
| 1. | Plenum connection | 4. | Kit no. 2 silencers DN 200 mm |
| 2. | Kit no. 4 rectangular/circular expulsion and intake plates | 5. | Aesthetic frames for installation of visible grilles |
| 3. | Ducting pipe | 6. | Aesthetic built-in grilles with plenum |

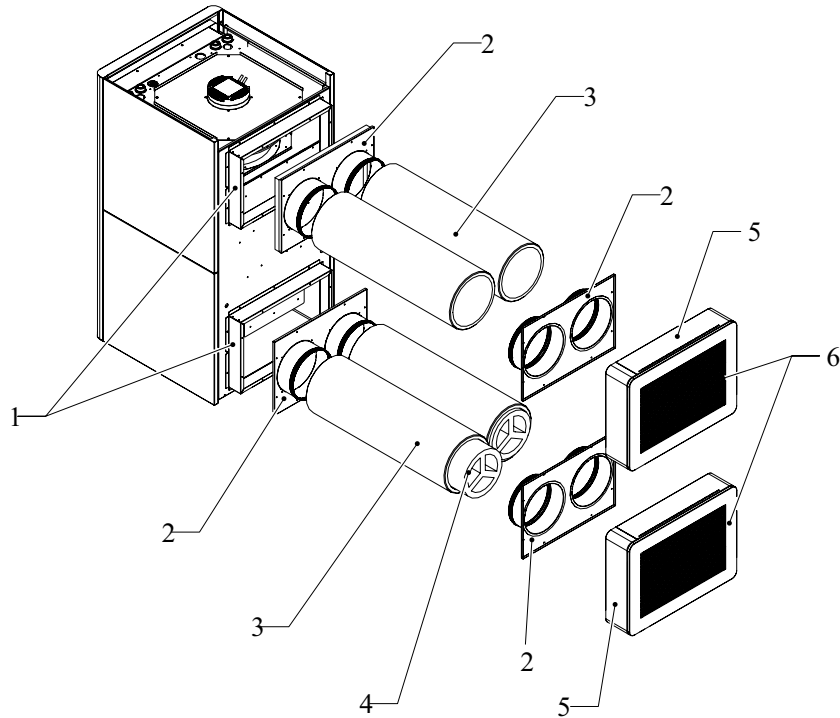

⚠ Please refer to chapter "Compatible accessories" [p. 16](#) for the list of available accessories.

2.4 Configurations

2.4.1 SV - Version with vertical coupling

1. Heat pump module

2. DHW module

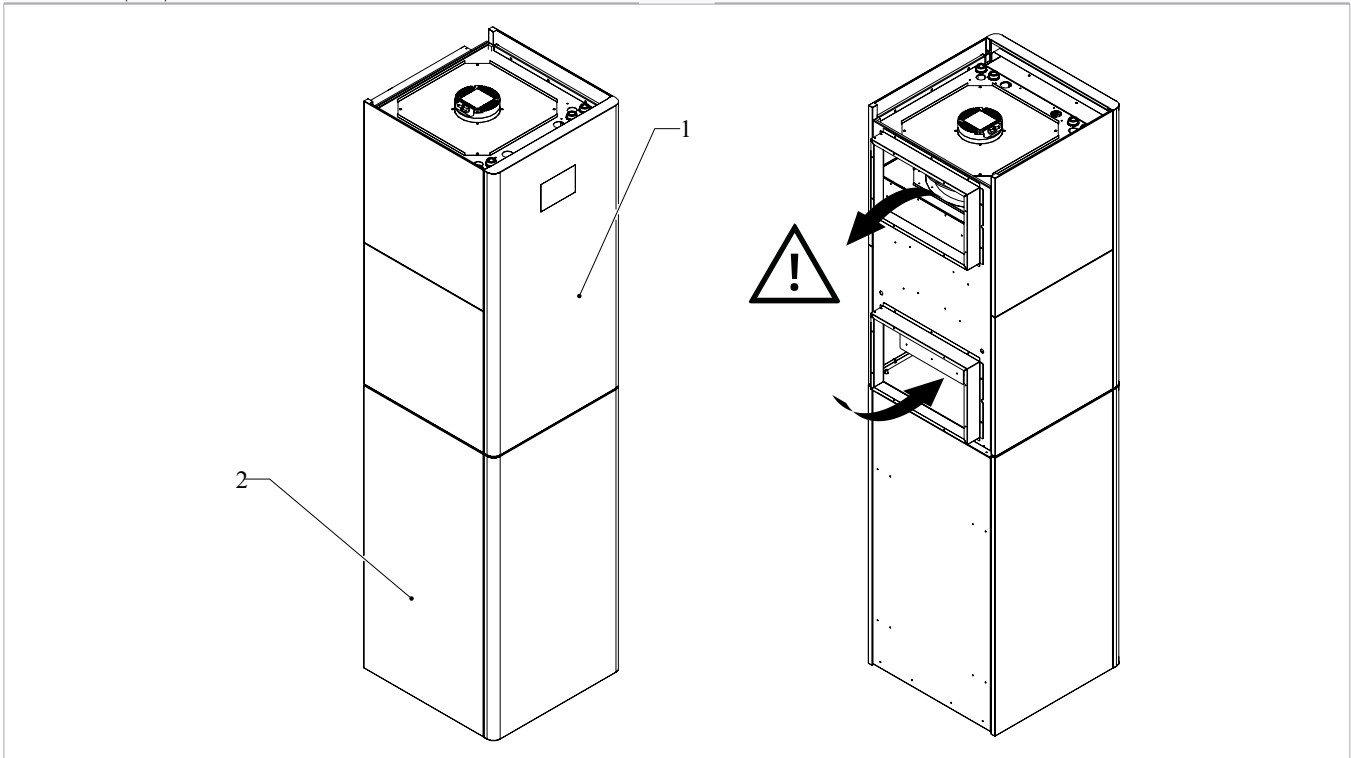

⚠ As standard, the units are configured with air outlet and intake at the back.

⚠ It is possible to configure the air outlet and intake on three sides during installation.

2.4.2 SH - Version with horizontal coupling

1. Heat pump module

2. DHW module

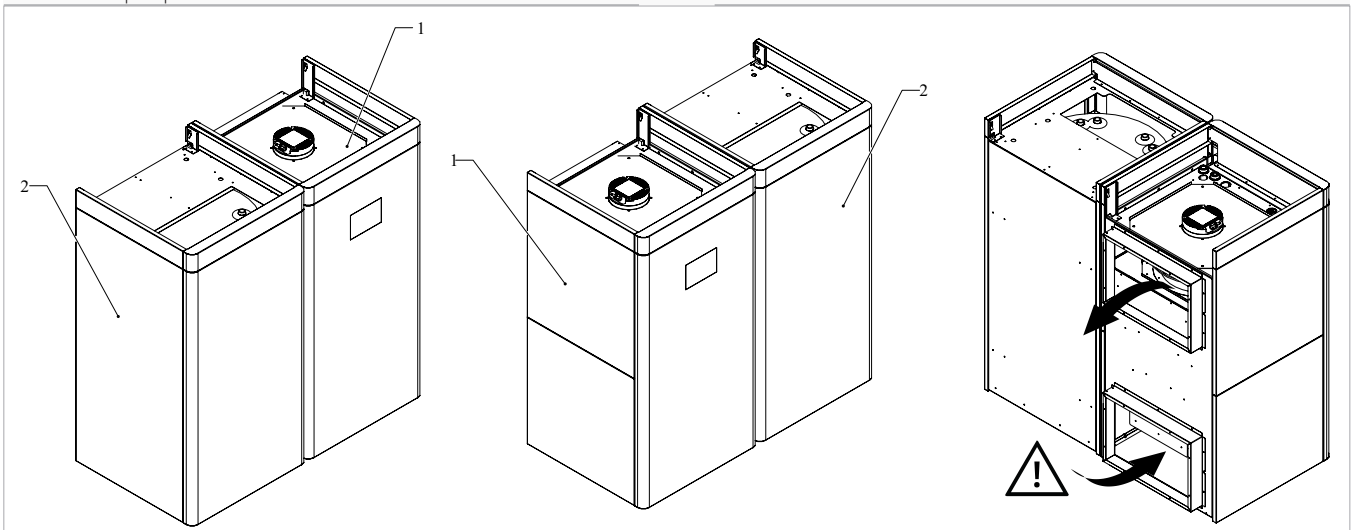

⚠ As standard, the units are configured with air outlet and intake at the back.

⚠ It is possible to configure the air outlet and intake on three sides during installation.

2.4.3 S - Single version

1. Heat pump module

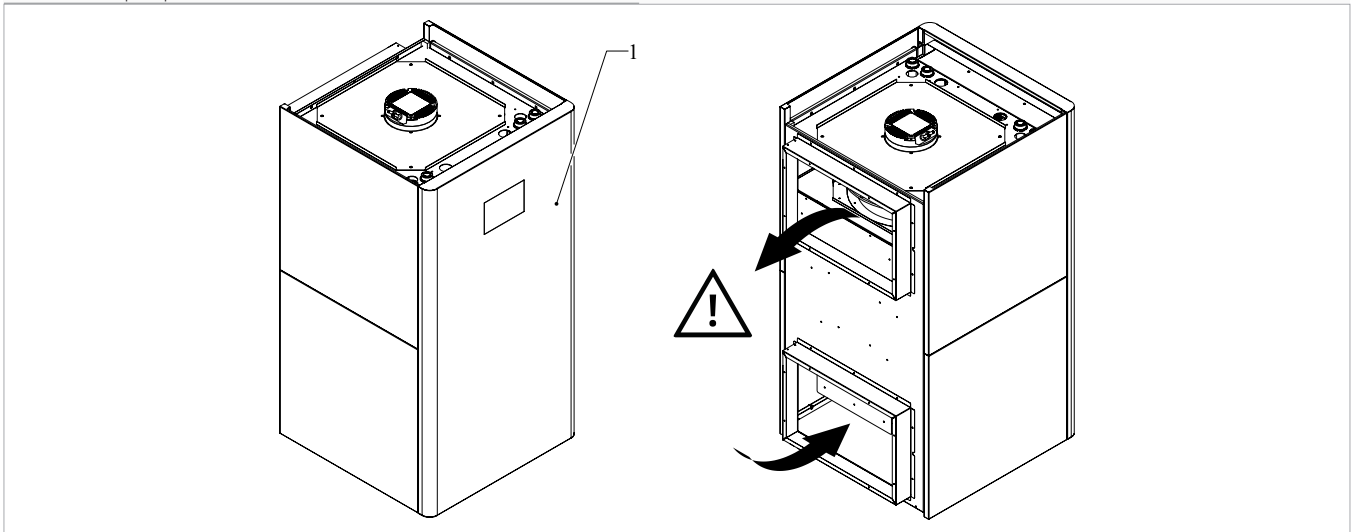

⚠ As standard, the units are configured with air outlet and intake at the back.

⚠ It is possible to configure the air outlet and intake on three sides during installation.

2.5 List of external components

2.5.1 Heat pump module

- 1. Control Panel
- 2. Front panel
- 3. Upper side aesthetic panel

- 4. Lower side aesthetic panel
- 5. Plenum connection

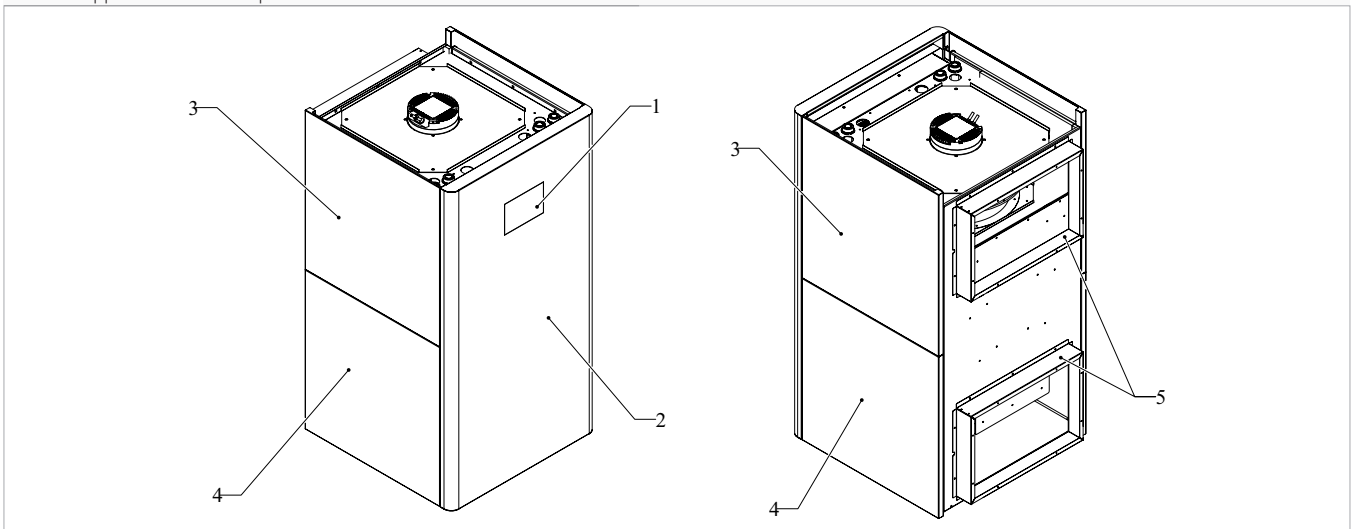

2.5.2 DHW module

- 1. Front panel
- 2. Aesthetic side panel

- 3. Backrest

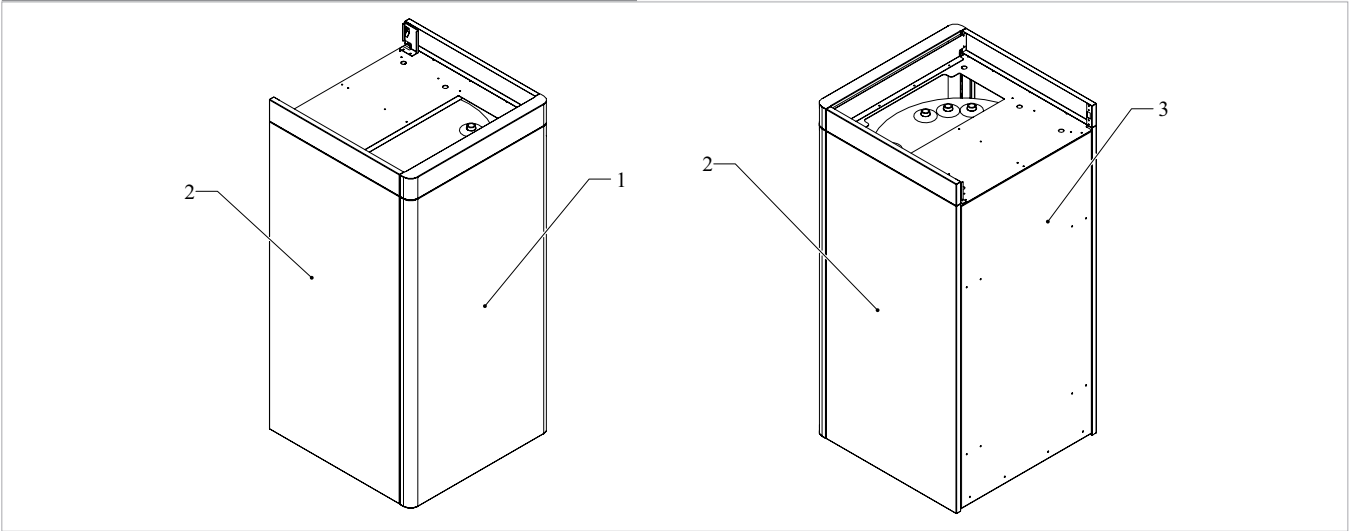

2.6 List of internal components

2.6.1 Heat pump module

- 1. Electrical panel
- 2. Heating element collector
- 3. Inverter driven rotary compressor
- 4. PP1 primary circulation pump
- 5. Liquid receiver
- 6. Differential pressure switch

- 7. 3-bar safety valve
- 8. Plate heat exchanger
- 9. Panel for aeraulic connection configuration
- 10. External air heat exchanger
- 11. Single suction fan
- 12. Filter

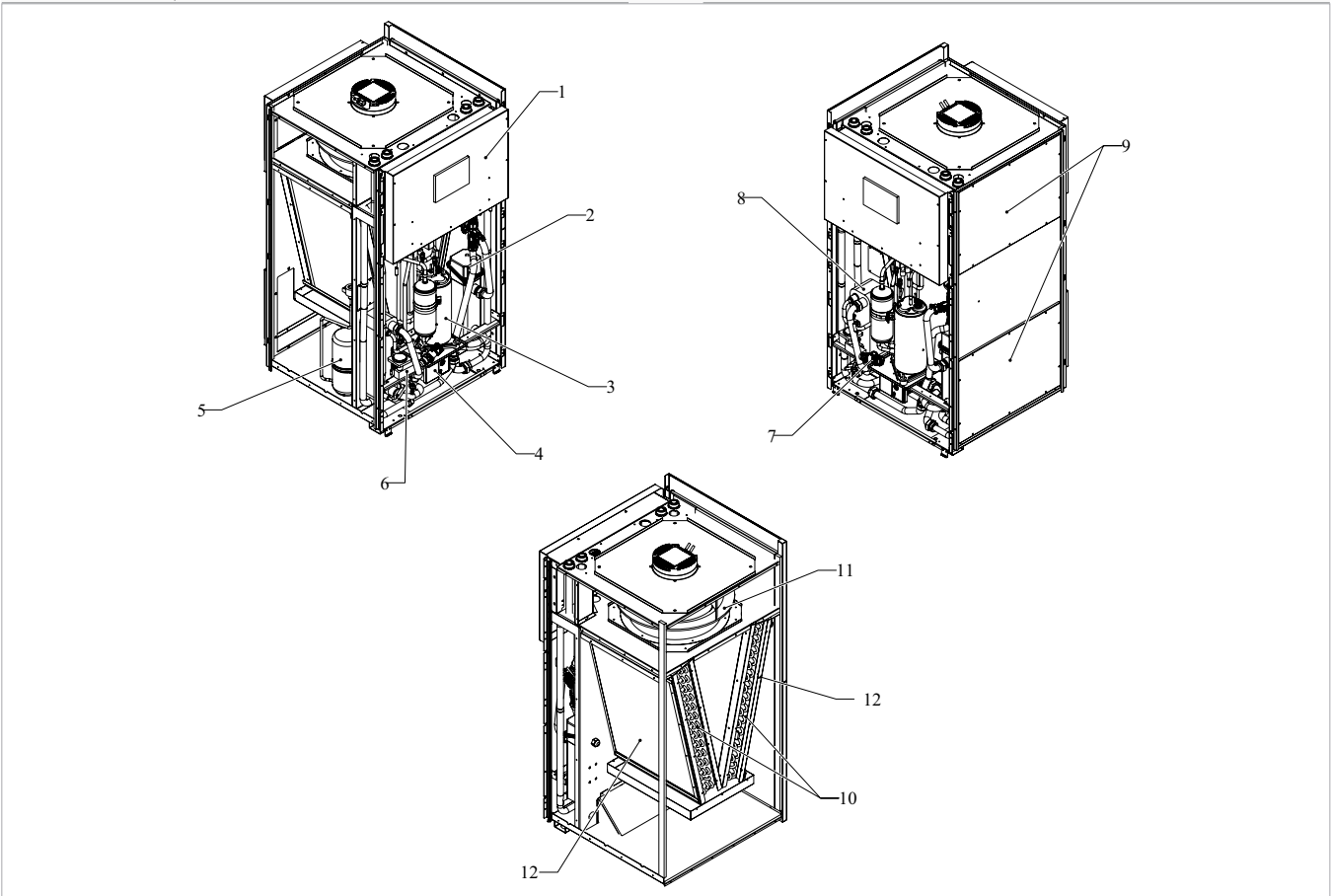



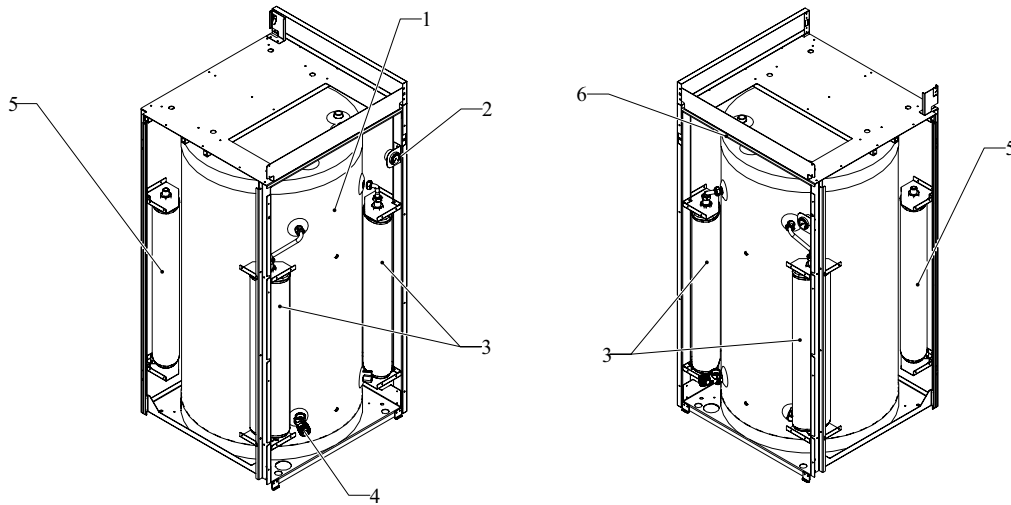

2.6.2 DHW module



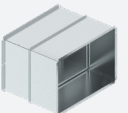
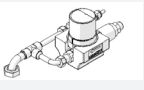

- | | | | |
|----|-------------------------|----|------------------------|
| 1. | Tank | 4. | 6-bar safety valve |
| 2. | Pressure gauge | 5. | Heating expansion tank |
| 3. | Sanitary expansion tank | | |



2.7 Compatible accessories

	Accessory description	Combinable products	Code
Network controls			
Butler			
	BUTLER: codes, accessories and price list in relevant section	All	
Accessories supplied separately			
Expulsion/intake plate			
	Kit no. 4 rectangular/circular plates for holes DN 200 mm (2 delivery plates + 2 intake plates), connection nipple. Dimensions (bxhxp): 467x320x87,5 mm	All	APDC0013II
Expulsion/intake grids			
	Aesthetic built-in grilles with plenum. Dimensions of built-in part (bxhxp): 460x313x120 mm. Grid dimensions (bxhxp): 542x400x16 mm	All	APDC0014II
	Aesthetic frame to be combined with accessory APDC0014II for installation of exposed aesthetic grille. Dimensions (bxhxp): 542x400x109 mm	All	APDC0015II
Telescopic channel			
	Telescopic channel, length 200 mm to 400 mm. Dimensions side 460x313 mm, external side 470x353 mm.	All	APDC0011II
Sanitary recirculation kit			
	Domestic hot water recirculation kit consisting of: recirculation pump, check valve, copper pipe and brass nipple M/M 1/2" G. Allows hot water to be available immediately at all supply points in the home, avoiding wasted water waiting for it to reach the desired temperature	All	APDC0016II
Differential valve			
	Valvola differenziale in ottone. Accessorio suggerito per agevolare la fase di collaudo	All	APDC0017II
EPP ducts			
EPP rigid pipe			
	Rigid insulating vapour-tight pipe / DN 200 mm, EPP material, price in €/m. 1 sleeve included. Suitable for inlet, exhaust, delivery to supply collector and inlet to extractor collector. Working temperature: -25/+80 °C. Conductivity: 0.042 W/mK.	All	SCE200001II
Flexible ducts			
Alufonic insulated flexible hose			
	Flexible duct with aluminium/polyester/aluminium wall complete with: harmonic steel wire helicoidal spiral, insulating polyester fibre covering (25 mm thick, 16 kg/m ³) to prevent dispersion of microfibres and external protection in aluminised film (flame retardant). Working temperature: -30/+140°C. Bending radius: min. 800 mm. Supplied in rolls of 10 meters. Price in € / meter	All	SCE320010II (1)

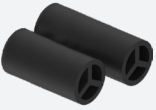
1. For use up to a length of 10 m between unit and external grille

	Accessory description	Combinable products	Code
Fixing ties			
	Fixing clamp for steel pipe / DN 60÷215 mm. Pack of 10 pcs, price in €/pcs.	All	SCE099120II
Silencers			
Flexible silencer			
	Aluminum concentric hose silencer with 25 mm of resins and mineral wool sandwiched between. Including gaskets for tight coupling on both ends.. Bending radius: min 3xDN 200 mm, attachment: M/M	All	SCE220001II
Silencer			
	Kit no. 2 silencers DN200 mm, for outdoor noise reduction to be placed on the outlet air. Length 480 mm	All	AHRC0038II
	Rectangular silencer to be placed on the air outlet. Dimensions (bxhxp): 440x292x199 mm	All	APDC0012II

1. For use up to a length of 10 m between unit and external grille

INSTALLATION

3.1 Preliminary warnings

- ⚠ **This section is dedicated to the Installer. The features of the installer are described in the "Recipients" p. 6 chapter.**
- ⚠ **For detailed information on the products, refer to chapter "Technical data" p. 58.**
- ⚠ The installation must be carried out by the installer in accordance with national installation regulations. There is a risk of water leakage, electric shock or fire if the installation is not performed correctly.
- ⚠ During the installation, it is necessary to observe the precautions mentioned in this manual, and on the labels placed inside the equipment, as well as to adopt any precaution suggested by common sense and by the Safety Regulations in force in the place of installation.

- ⚠ Be sure to use the supplied or specified installation parts. Use of other parts may cause the unit to come to lose, water leakage, electrical shock, or fire.
- ⚠ Failure to apply the indicated rules may cause malfunctions of the appliances and relieves the manufacturer from any warranty and from any damage caused to persons, animals or property.

3.1.1 Preliminary warnings for R32

- ⚠ Safety checks must be carried out to ensure that the risk of combustion is minimised before starting work on systems containing flammable refrigerants.
- ⚠ The appliance must be protected against accidental impacts to prevent mechanical damage.
- ⚠ Do not puncture or burn.

3.2 Reception

3.2.1 Preliminary warnings

- ⚠ on receipt check them for any damage and, if any is found, accept the goods with reservation, and keep photographic evidence of any damage found
- ⚠ In the event of damage, notify the shipper within 3 days of receipt of any damage by registered mail with return receipt, submitting photographic evidence. Similar information should be sent by fax to the manufacturer (jurisdiction will be at the Court Trento for any dispute).
- ⚠ No notice of damage will be accepted after 3 days from delivery.

Preliminary warnings for R32

- ⚠ Check if there is refrigerant inside the package using an electronic leak detector suitable for the system refrigerant. If it is present, the refrigeration circuit is likely damaged. In this case, do not install the appliance and call the Technical Assistance Centre.

3.2.2 Package description

The packaging is made of suitable material and carried out by experienced personnel.
 The appliance is shipped in standard packaging consisting of a cardboard sleeve and a set of expanded polystyrene protectors.
 There is a pallet underneath the packaging of the unit to facilitate transport and moving.
 Units are delivered complete and in perfect condition.

3.3 Dimensions and weights with packaging

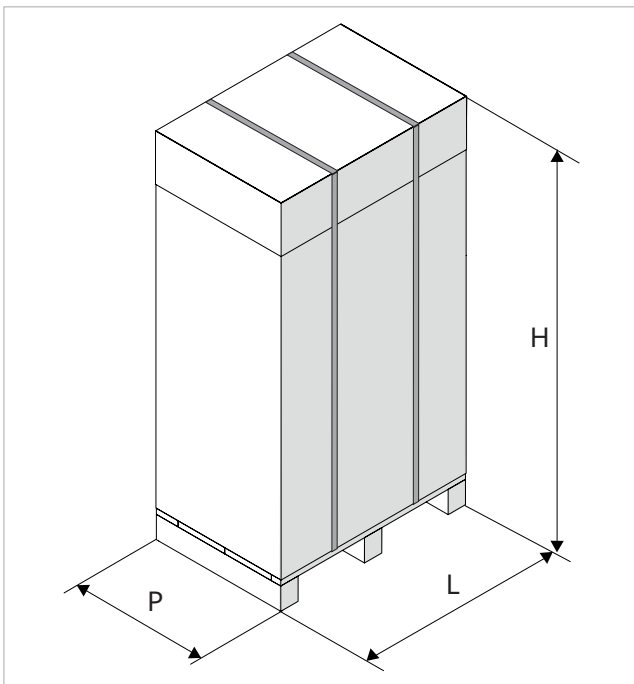

3.3.1 Heat pump module

Models	m.u.	5	7
Dimensions and weight for shipping			
Width	mm	760	760
Height	mm	1400	1400
Total depth	mm	760	760
Weight	kg	135,0	135,0

3.3.2 DHW module

Models	m.u.	5	7
Dimensions and weight for shipping			
Total width	mm	760	760
Total height	mm	1400	1400
Total depth	mm	760	760
Weight	kg	125,0	125,0

3.4 Handling with packaging

3.4.1 Preliminary warnings

- ⚠ The appliance must be handled only by qualified personnel, adequately equipped and with equipment suitable for the weight and dimensions of the appliance.
- ⚠ Before moving the unit, check the lifting capacity of the machinery used following the instructions on the packaging.
- ⚠ Stay clear of the area below and around it when the load is lifted off the ground.
- ⚠ If a forklift truck is used, put the base in the appropriate openings.
- ⚠ Avoid dangerous situations when using a hoist to lift the appliance.
- ⚠ Move the unit to an upright position.
- ⚠ Do not turn the packaging upside down.
- ⚠ Do not stack the appliances.

3.4.2 Movement methods

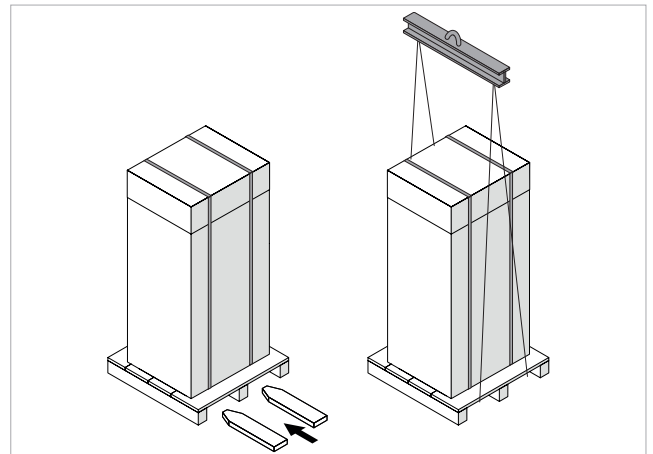

The product can be handled as follows:

- using a hoist or a crane
- using a fork lift or a transpallet which can bear its weight

- ⚠ Use a small balance to prevent the pressure of the belts damages the unit.

3.5 Storage

3.5.1 Preliminary warnings

- ⚠ Stored in accordance with the applicable national regulations.
- ⚠ Do not turn the packaging upside down.

- ⚠ Do not stack the appliances.
- ⚠ Only place the appliance in a vertical position.

Preliminary warnings for R32

- ⚠ The appliance must be protected against accidental impacts to prevent mechanical damage that causes leakage of refrigerant.
- ⚠ The appliance must be placed in a room where there are no open flames continuously in operation (e.g. a gas appliance in operation) and no sources of ignition (e.g. an electric heater in operation).

3.5.2 Appliance with packaging

Store the package:

- in a dry and clean place
- in a closed environment protected from atmospheric elements
- insulated from the ground by crossbars or pallets

3.5.3 Appliance without packaging

The following procedures are recommended in the case of medium to long term storage:

- check that no water is present in the hydraulic systems
- do not remove plastic protective films
- check that the electrical panels are closed

3.6 Unpacking

3.6.1 Preliminary warnings

- ⚠ **All aesthetic panels must be removed before removing the appliance from the pallet.**
- ⚠ Check that no components were damaged during transport.
- ⚠ Dispose of the packaging components following the applicable waste disposal regulations. Check for disposal arrangements with your municipality.
- ⊖ The packing material (cardboard, staples, plastic bags, etc.) must not be dispersed or abandoned in the surrounding environment and must be kept out of children reach, as it can be dangerous.

Specific warnings for R32

- ⚠ Check if there is refrigerant inside the package using an electronic leak detector suitable for the system refrigerant. If it is present, the refrigeration circuit is likely damaged. In this case, do not install the appliance and call the Technical Assistance Centre.
- ⚠ Check that there are no sources of ignition in continuous operation (open flames, gas appliances, electric stoves, lighted cigarettes, etc.).
- ⊖ Using leak detectors with halogen lamps is prohibited.
- ⊖ Smoking in the vicinity of the appliance is prohibited.
- ⊖ Using a mobile phone near the appliance is prohibited.

3.6.2 Remove the package

1. Strapping

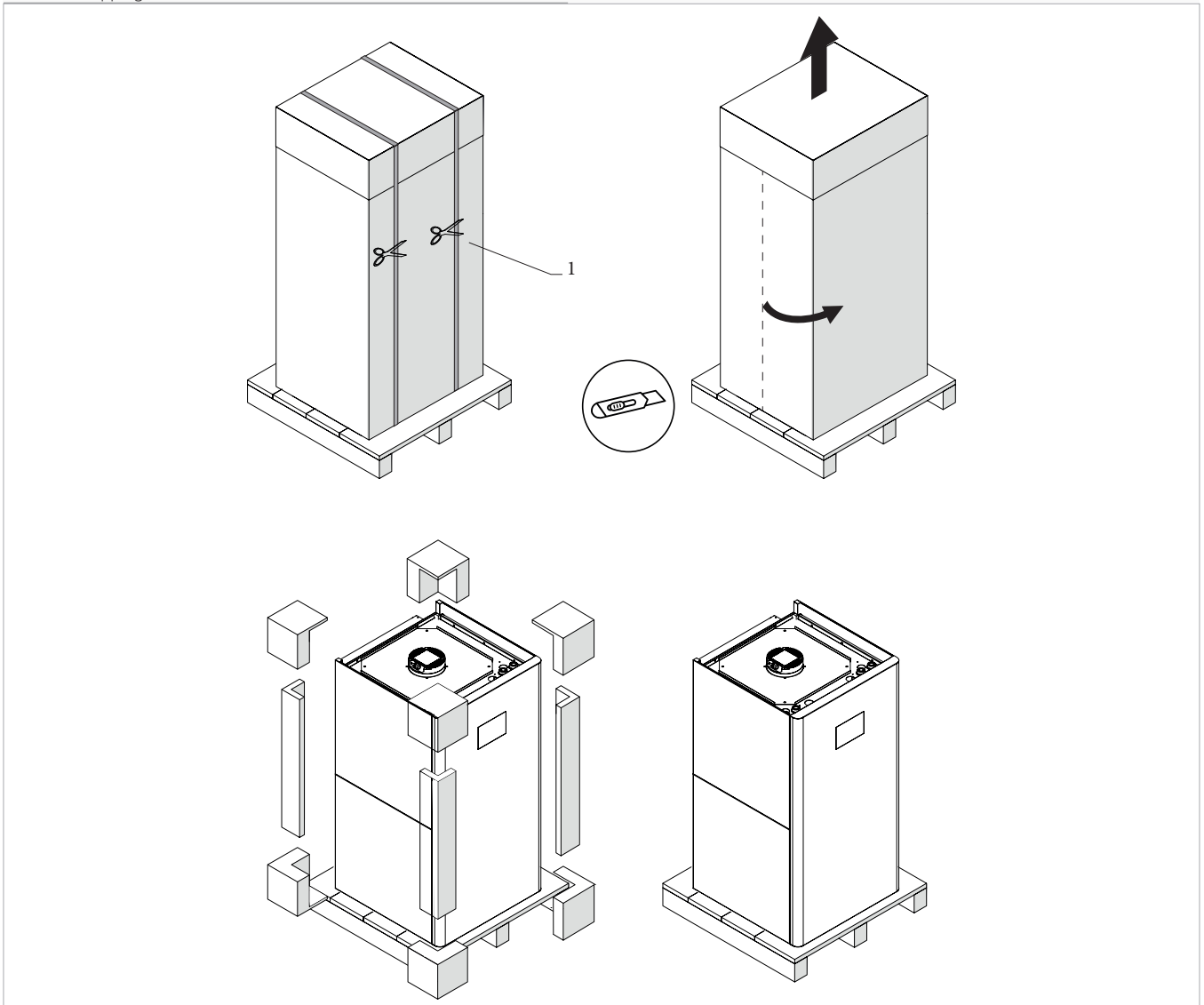

Remove the packing:

- cut the strapping
- remove the upper cover
- use a cutter
- cut vertically
- remove the packing
- remove the polystyrene elements

⚠ All aesthetic panels must be removed before removing the appliance from the pallet.

Accompanying material

They are included with the appliance, inside the packaging:

⚠ Check the presence of the individual components.

S - Single version

- 1 installer manual of the unit
- 1 user and installer manual for the Control Panel
- 1 plant probe
- 1 first start-up form
- 1 installation template for the back
- 1 installation template for the right side
- 1 installation template for the left side

- 1 net filter

SH - Version with horizontal coupling

- 1 installer manual of the unit
- 1 user and installer manual for the Control Panel
- 1 domestic hot water probe
- 1 first start-up form
- 1 installation template for the back
- 1 installation template for the right side
- 1 installation template for the left side
- 1 net filter

SV - Version with vertical coupling

- 1 installer manual of the unit
- 1 user and installer manual for the Control Panel
- 1 domestic hot water probe
- 1 hydraulic connection pipe kit
- 1 first start-up form
- 1 installation template for the back
- 1 installation template for the right side
- 1 installation template for the left side
- 1 net filter

3.7 Removal of aesthetic panels

3.7.1 Heat pump module

- 1. Front panel
- 2. Top covering (only for SH version)
- 3. Upper side aesthetic panel

- 4. Lower side aesthetic panel
- 5. Access panel

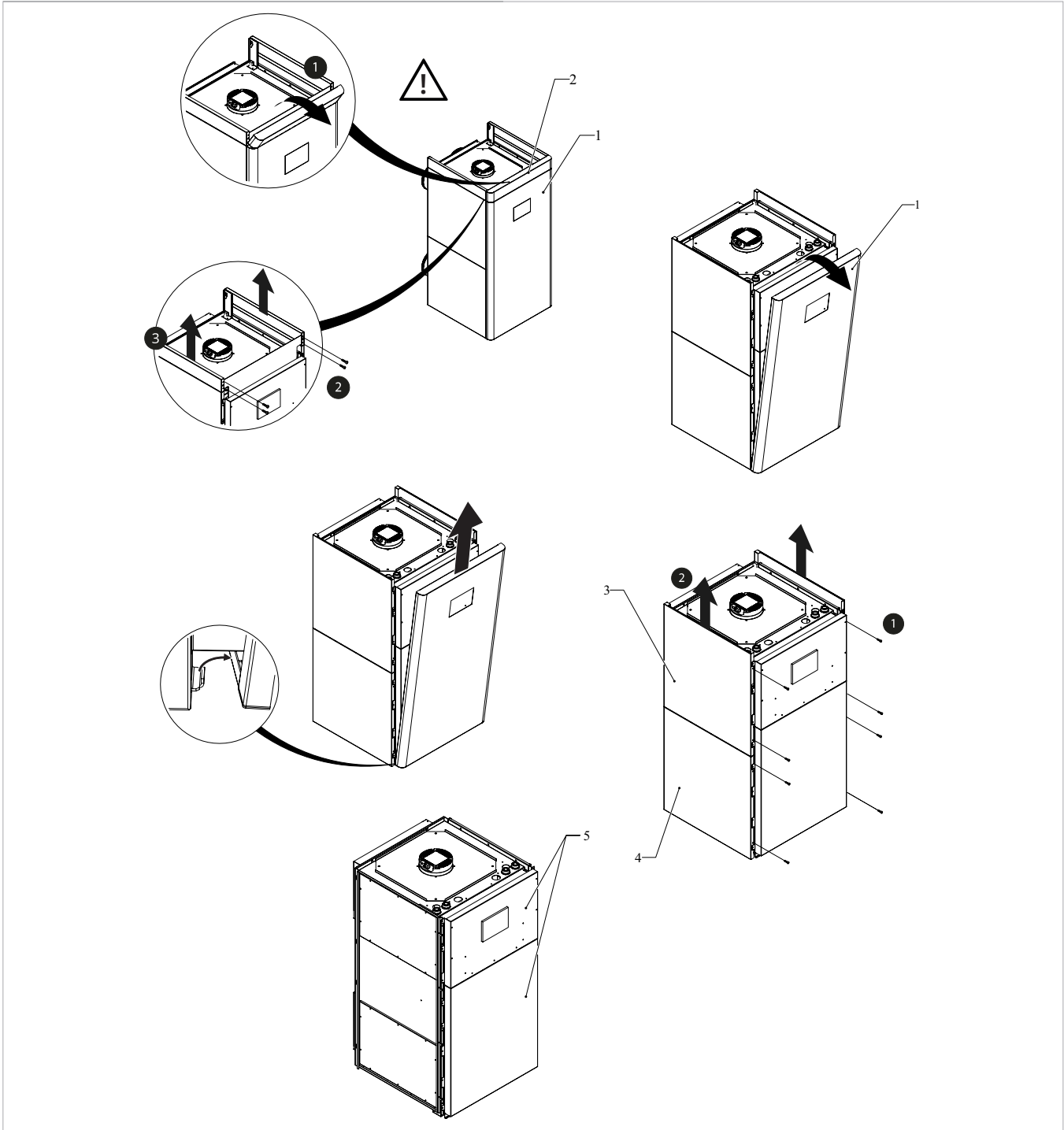

- ⚠ Top covering available only for the SH version.
 - remove top covering (only for SH version)
 - open the front panel by turning it downwards
 - remove the aesthetic front panel
 - unscrew the fixing screws of the side panels
 - remove the side panels

- ⚠ Do not install the cosmetic panels until all connections have been established.

- ⊘ Removing the side panels without completely removing the fixing screws is forbidden.

3.7.2 DHW module

- 1. Front panel
- 2. Top covering (only for SH version)

- 3. Cosmetic side panel

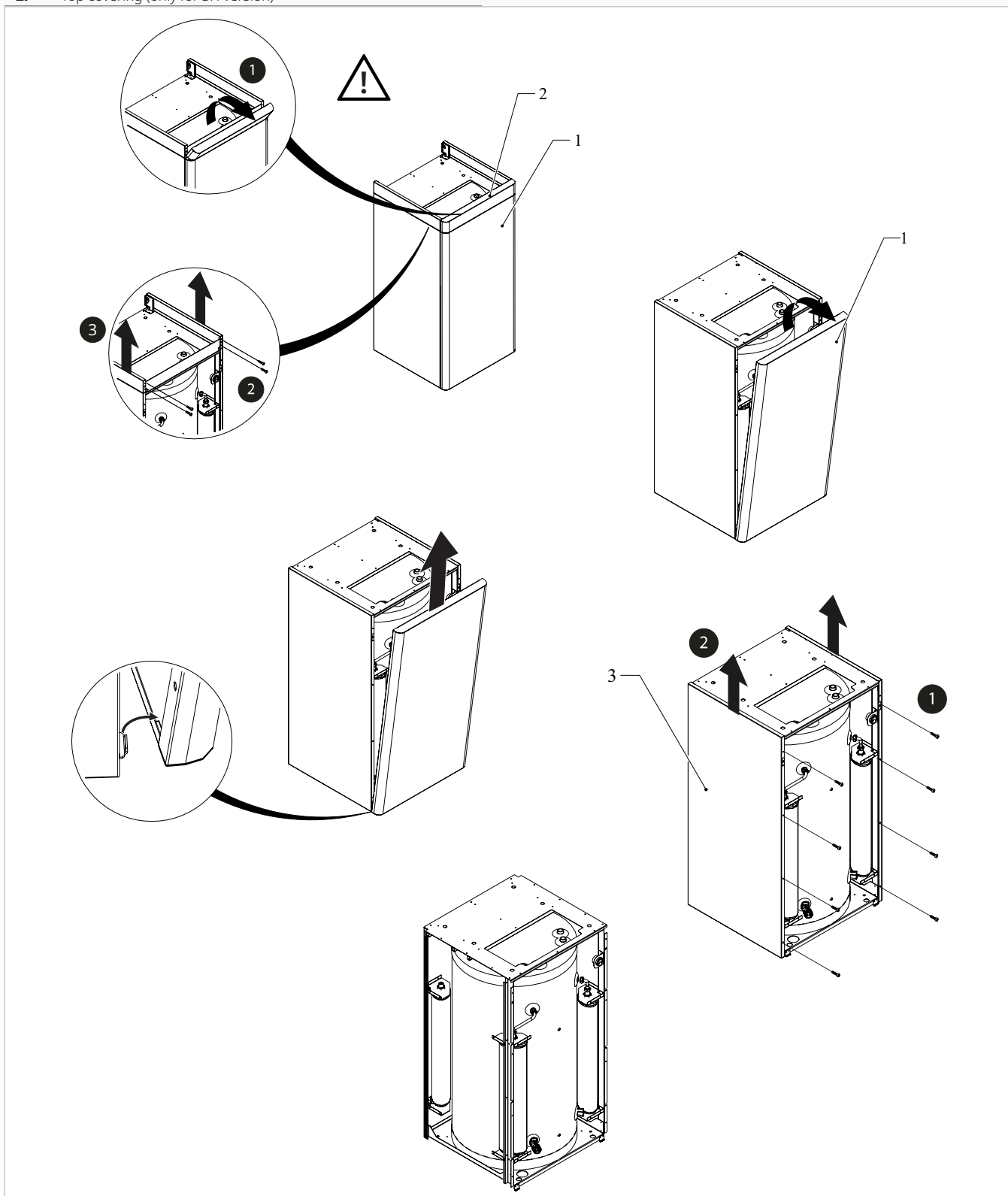

- ⚠ Top covering available only for the SH version.
 - remove top covering (only for SH version)
 - open the front panel by turning it downwards
 - remove the aesthetic front panel
 - unscrew the fixing screws of the side panels
 - remove the side panels

- ⊘ Removing the side panels without completely removing the fixing screws is forbidden.
- ⚠ Do not install the cosmetic panels until all connections have been established.

3.8 Handling without packaging

3.8.1 Preliminary warnings

- ⚠ The appliance must be handled only by qualified personnel, adequately equipped and with equipment suitable for the weight and dimensions of the appliance.
- ⚠ Move the unit to an upright position.

- ⚠ The unit is provided with four ball wheels to facilitating handling.
- ⚠ The use of protective gloves is mandatory.
- ⚠ The use of protective shoes is mandatory.

3.8.2 Movement methods

- ⚠ The following movement method is applicable to both modules.

- | | |
|----|--------------------------|
| 1. | Ball wheels for movement |
| 2. | Locking feet |

- | | |
|---|------------------|
| A | Heat pump module |
| B | DHW module |

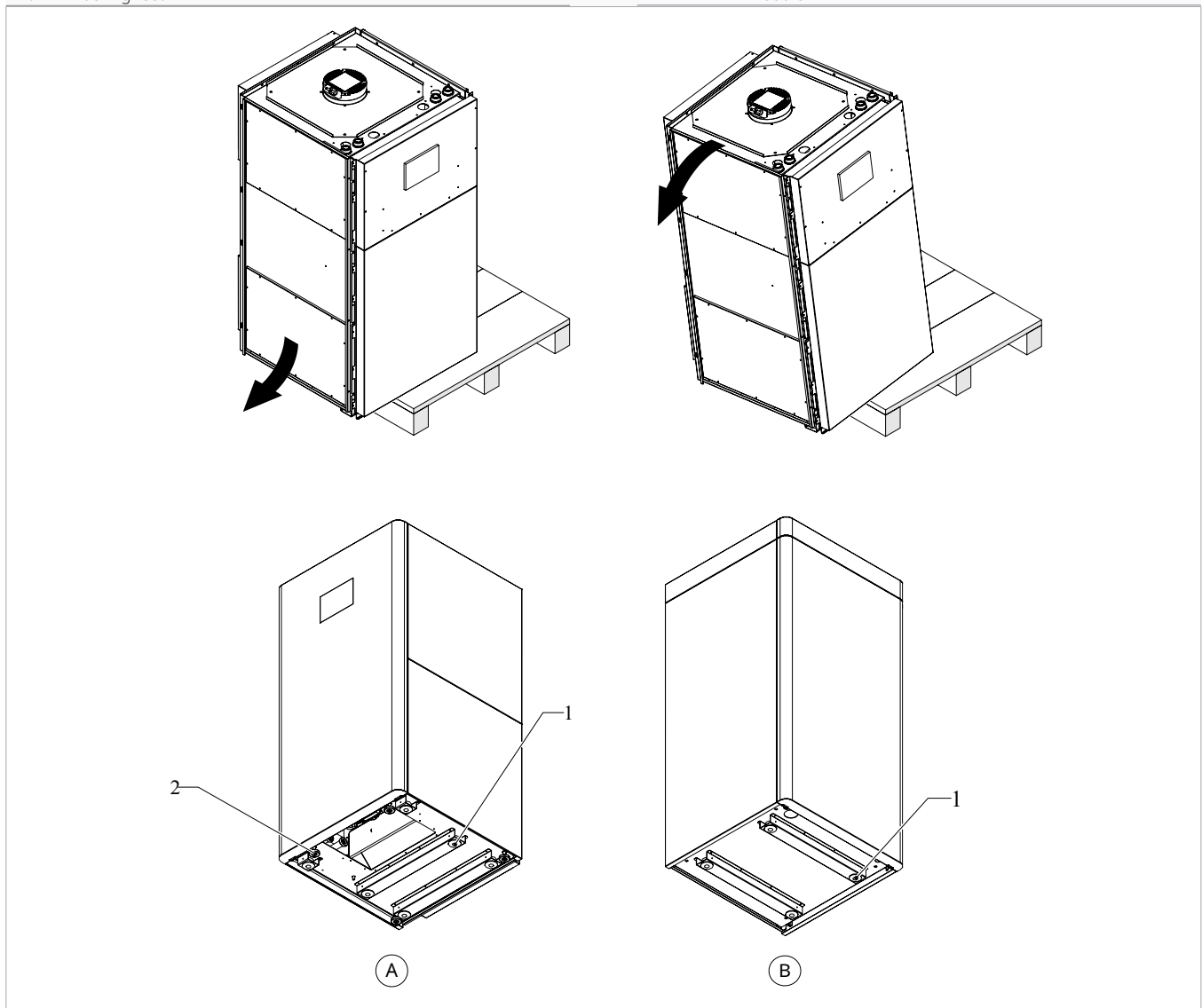

- ⚠ Movement method valid for both modules.

To handle:

- slide the appliance slowly
- turn the appliance to rest it on the ground
- slide the pallet out completely
- move the unit by pushing it

- ⚠ If there are any delicate surfaces, provide wooden panels or some floor coverings.

- ⚠ The machine must be handled with the utmost care to prevent the unit from tipping over.

3.9 Installation site

The location of the appliance must be determined by the plant engineer or a competent person and must take into account both purely technical requirements and any national/local legislation in force.

The appliance is intended to be installed indoors.

Depending on the version, the expected installation methods are:

3in1 Mono - SV version with vertical coupling

- exposed with combination of modules on top of each other with floor positioning

3in1 Mono - SH version with horizontal coupling

- exposed with side-by-side modules with floor positioning

3in1 Mono - S single version

- exposed with floor positioning

3.9.1 Preliminary warnings

- ⚠ Avoid installing the unit in:
 - utility shafts and/or hopper window
 - near obstacles or barriers that cause recirculation of exhaust air
 - narrow places where the sound level of the appliance can be enhanced by reverberations or resonances
 - bedrooms and places used for resting
 - places where dust and anything else that may reduce the efficiency of the appliance by obstructing the passage of air from the external grills is usual
 - environments with the presence of flammable or explosive gases
 - very humid environments (laundries, greenhouses, etc.)
 - environments with aggressive atmospheres
 - environments with the presence of steam or mineral oil mist
 - solar radiation and proximity to heat sources
 - areas prone to strong gusts of wind
 - places with strong voltage fluctuations
- ⚠ The sound level measured under actual installation conditions may be higher than that indicated in the technical data of the unit due to ambient noise and acoustic reflections.
- ⚠ Avoid placing the unit within 1 metre of radio and video equipment.
- ⚠ Avoid installation in locations directly exposed to sea winds. The saline atmosphere accelerates the corrosion process of the materials reducing the life of the unit.
- ⚠ Avoid placement in vehicles or on ships.
- ⚠ Make sure that:
 - the installation site of the unit must be chosen with the utmost care to guarantee adequate protection from shocks and consequent damage
 - the supporting surface or wall can bear the weight of the appliance
 - the section wall does not involve load-bearing construction elements, piping or electrical lines
 - no load-bearing elements of the construction are compromised
 - the appliance must be installed in a position where it can be easily serviced
 - the safety distances between the units and other appliances or structures are scrupulously respected so

that the air entering and leaving the fans is free to circulate

- air expulsion is not hindered by strong winds in the opposite direction

- ⚠ Baffle panels must be installed in case of installation in places with strong gusts of wind in direction opposing the air expulsion. Take the minimum distances shown under "Installation minimum distances" [p. 26](#) into account.

- ⚠ If the appliance is installed incompletely or on an inappropriate base, it could cause damage to persons or property if it should detach from its base.

- ⚠ Provide the following:
 - a drain and a water supply nearby
 - a compliant power supply nearby
 - fixing elements suitable for the type of support

Preliminary warnings for R32

- ⚠ **The refrigerant charge means the total charge of the circuit given by the sum of the factory charge and any additional charge.**
- ⚠ Refer to the rating plate on the paired outdoor unit for the amount of refrigerant gas loaded in the unit.
- ⚠ If the appliance is located in a poorly ventilated place, precautions must be taken to prevent stagnation in the event of leakage of refrigerant to avoid creating a risk of fire or explosion.
- ⚠ The appliance must be placed in room where there are no open flames continuously in operation (e.g. a gas appliance in operation) and no sources of ignition (e.g. an electric heater in operation).
- ⚠ Any ventilation openings must be kept free of obstacles.
- ⚠ Perform the following checks:
 - carry out safety checks to ensure that the risk of combustion is minimised
 - avoid working in confined spaces
 - delimit the area around the workspace
 - ensure safe working conditions around the area by controlling flammable material

3.10 Installation minimum distances

The clearance zones for the installation and maintenance of the appliance are shown in the figure. Established spaces are necessary to avoid barriers to airflow and allow for normal cleaning and maintenance.

* The spaces given are only necessary if it is not possible to disconnect and remove the unit easily in the event of extraordinary maintenance.

⚠ Make sure that there is sufficient space to allow the panels to be removed for routine and supplementary maintenance operations.

⚠ The minimum installation distances given below apply to all versions.

1. Front panel

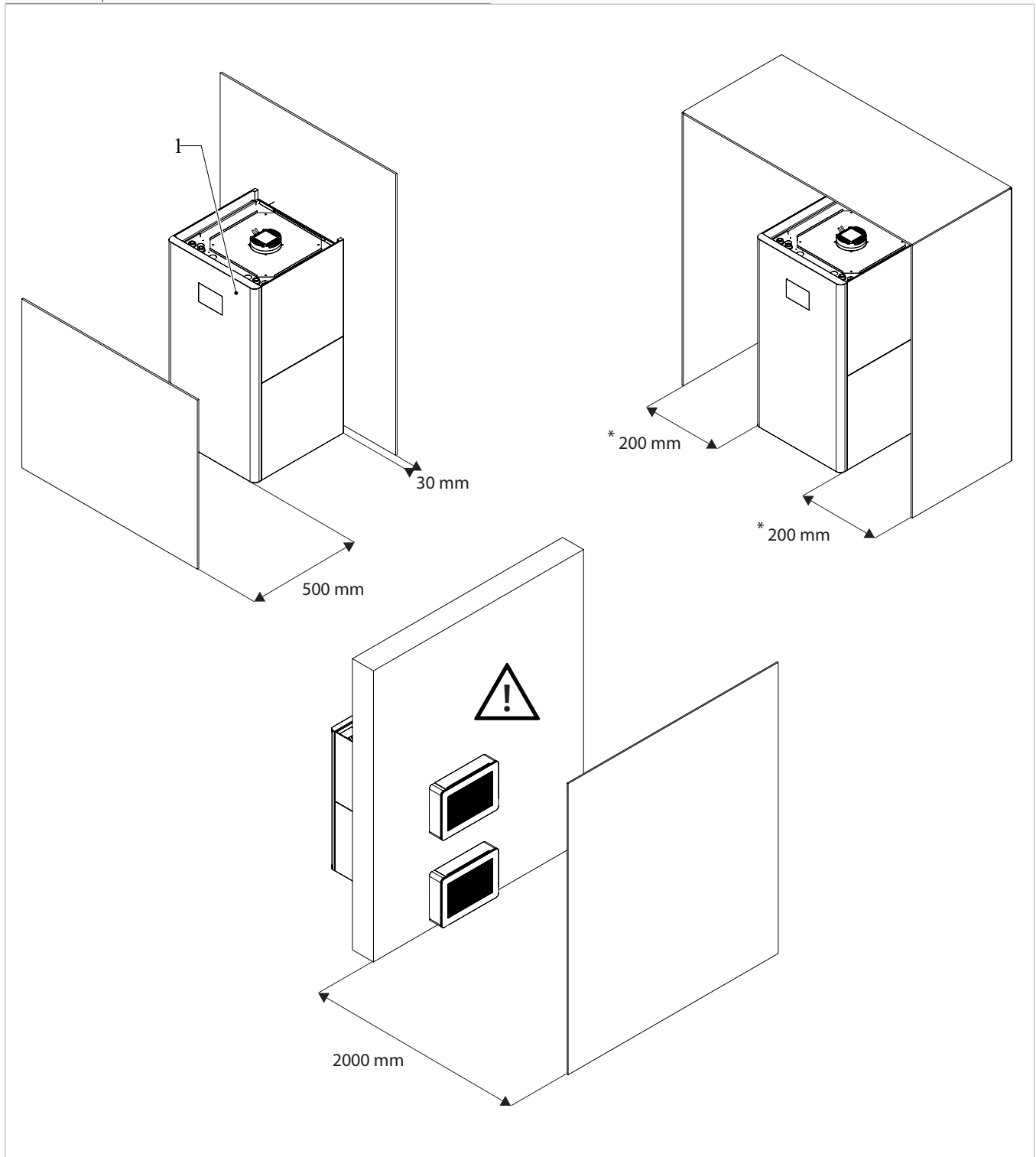

⚠ Take precautions to avoid bypass between air outlet and air intake.

3.11 predisposition to positioning

Before positioning the unit, it is necessary to configure the air outlet and intake.

It is possible to configure the air outlet and intake on three sides during installation. As standard, the units are configured with air outlet and intake at the back.

! The maximum duct development is 5 m.

3.11.1 Aeraulic connection configurations

- 1.** Front panel
- A** Air outlet and intake on the back of the unit (standard configuration)
- B** Left-side air outlet and intake
- C** Right-side air outlet and intake
- D** Air outlet at the back and air intake on the left side

- E** Air outlet on left side and air intake at the back
- F** Left-side air outlet and right-side air intake
- G** Air outlet at the back and air intake on the right side
- H** Air outlet on the right side and air intake at the back
- I** Right-side air outlet and left-side air intake

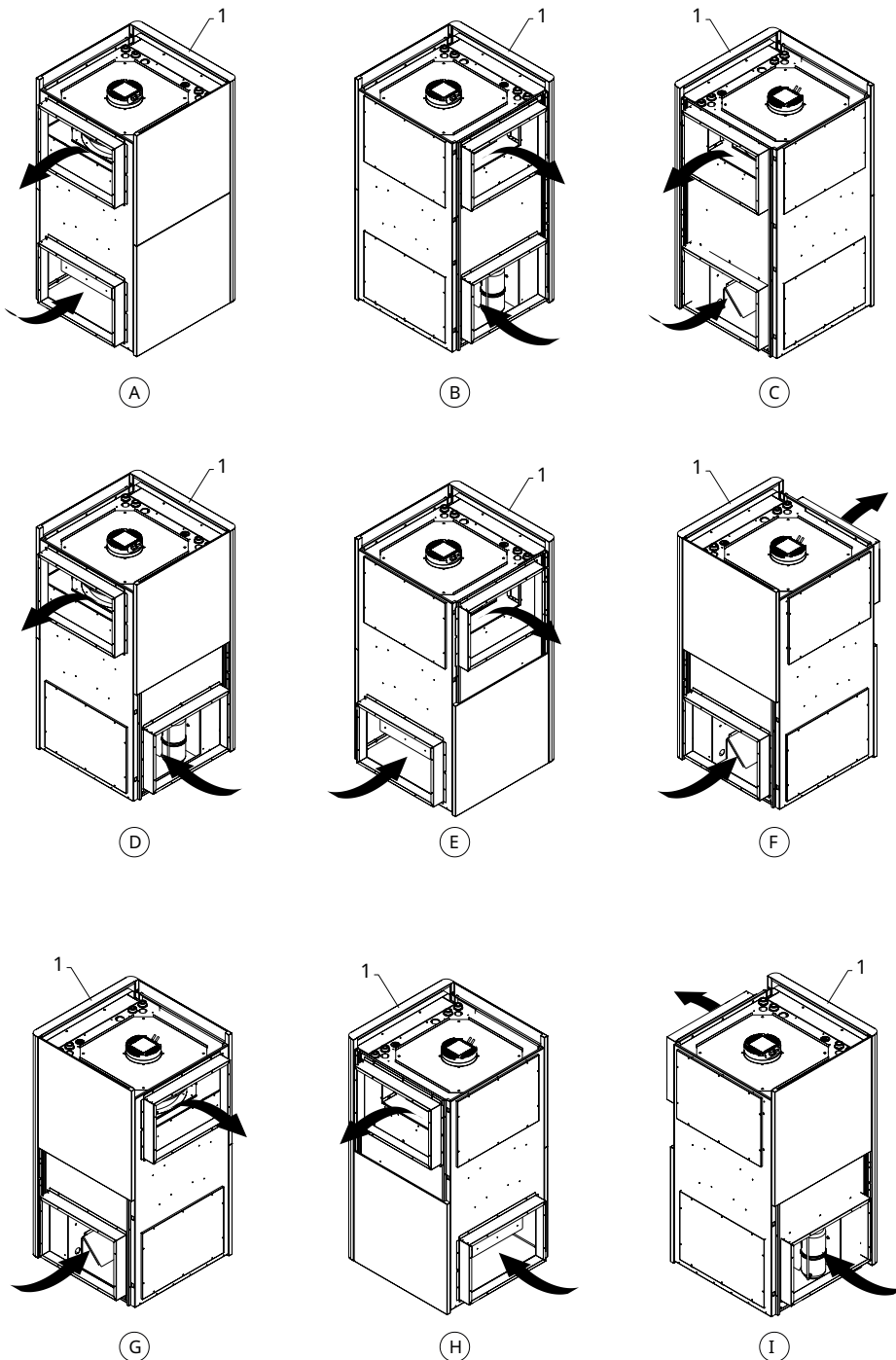

⚠ As standard, the units are configured with air outlet and intake at the back.

⚠ It is possible to configure the air outlet and intake on three sides during installation.

3.11.2 Modification of aeraulic connections

The configuration of the aeraulic connections can be changed by moving the panels and plenum connections to achieve the desired configuration.

- A** Air outlet and intake on the back of the unit (standard configuration)
- B** Air outlet on left side and air intake at the back

- 1.** Access panel
- 2.** Panel for aeraulic connection configuration
- 3.** Plenum connection

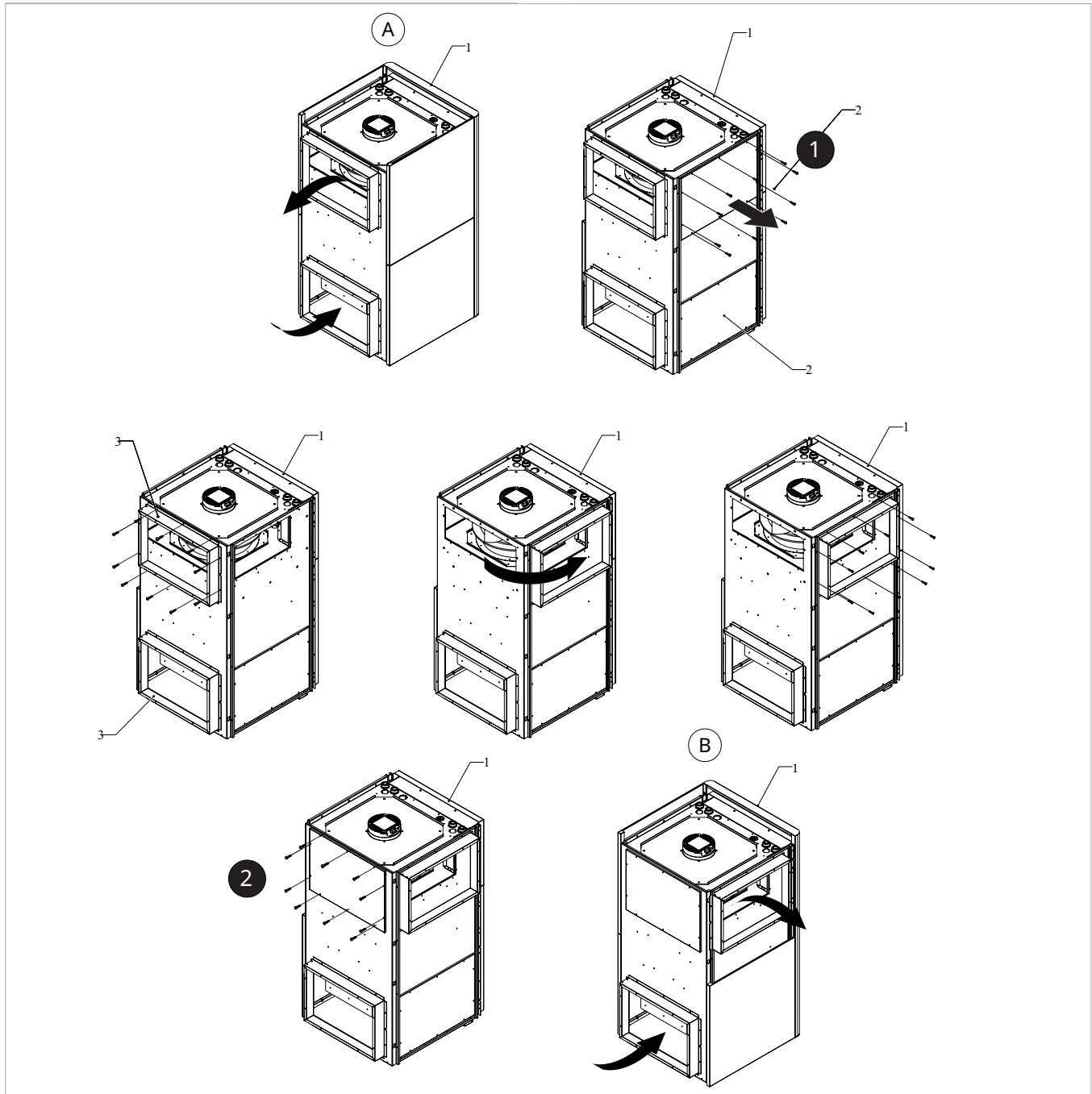

- unscrew the fixing screws of the panel to configure the aeraulic connections
- remove the panel
- unscrew the plenum connection fixing screws
- remove the plenum connection
- place plenum connection instead of panel
- fix the plenum connection with the screws
- place the panel

- fix the aesthetic panel with the screws

3.11.3 Preparation of the wall

The units are supplied with a paper template for marking the holes necessary for installation. Depending on the chosen configuration, use the template provided to mark out the holes in the wall.

1. Installation template

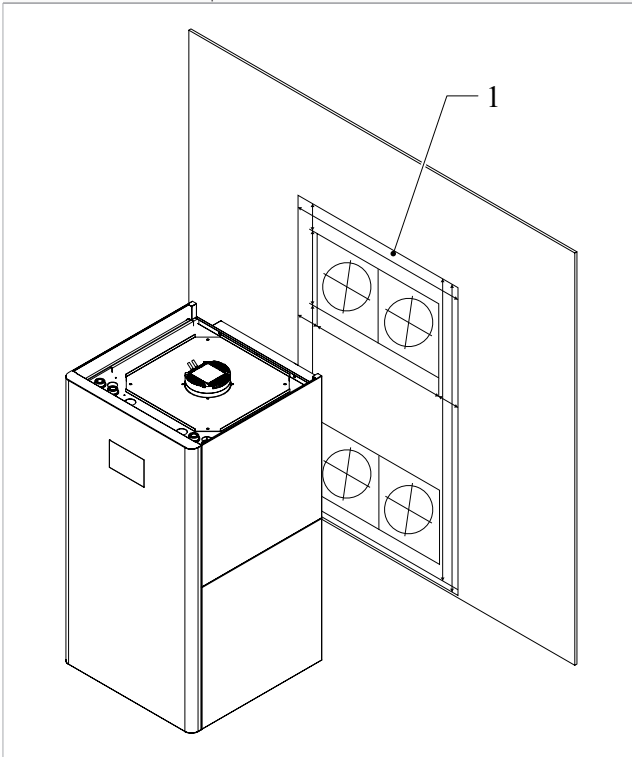

- ⚠ Hold the template in the correct position with tape.
 - position the paper template
 - mark the positions of the holes for the ducts
 - use a drill
 - drill a pilot hole
 - use a core drill in case of circular ducts
 - drilling the holes
 - keep a downward inclination toward the external side
- ⊖ Curves are forbidden.
- ⚠ The maximum duct development is 5 m.
- ⚠ To prevent the creation of large quantities of dust and debris in the room it is recommended to couple the core drill to a vacuum system.
- ⚠ Proceed with caution in the vicinity of the outer wall in order to avoid the breakage of plaster around the hole.
- ⚠ Take precautions so that the drilled material does not fall on persons and objects below.

3.12 Positioning

Exposed units can be positioned on the floor.

3.12.1 Preliminary warnings

- ⚠ Make sure that:
 - the supporting surface supports the weight of the appliance
 - the slab is sufficiently rigid and does not transmit vibrations to the rooms below or adjacent to it
 - the section of floor or wall does not involve load-bearing construction elements, piping or electrical lines
- ⚠ The unit is equipped with ball-bearing wheels for easy handling.
- ⚠ The unit is provided with locking and adjusting feet.

3.12.2 Positioning

- 1. Ball wheels for movement
- 2. Locking feet

- 3. Ball wheel anchor hole
- 4. Bolts for coupling

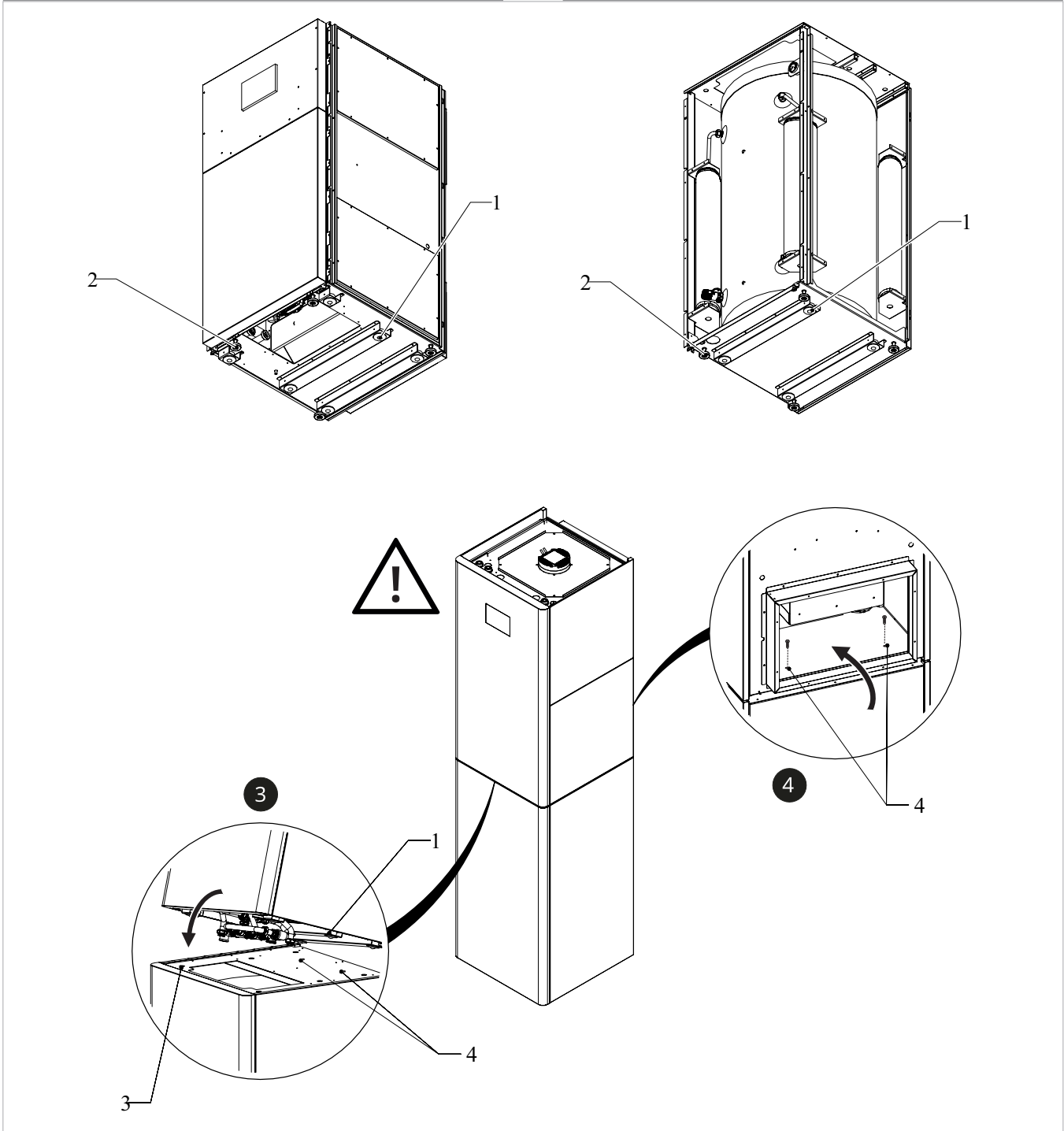

- ⚠ **For dimensional information, refer to chapter "Technical information" p. 58**
 - place the unit on a perfectly level surface
 - Adjust the two locking feet

For SV versions - Version with vertical coupling:

- ⚠ The bolts required for coupling are supplied installed on the DHW module.
- ⚠ Remove the coupling bolts before installing the unit.
 - place the DHW module on a perfectly levelled surface
 - unscrew the bolts for coupling

- place the heat pump module on the DHW module
- fix the ball wheels of the heat pump module into the holes provided on the ACS module
- access through the air intake hole
- secure the two modules with bolts for coupling
- move the unit closer to the wall

Make sure that:

- it is levelled
- easy access is allowed to the hydraulic and electrical parts

3.13 Aeraulic connections

3.13.1 Preliminary warnings

⚠ The engineer is responsible for choosing the right aer-
aulec connections and their size, in accordance with
good installation practices and the applicable law.

⚠ The aeraulic system is made by the installer and must
be carried out with reference to the diagrams in this
manual or on the website.

⚠ The air ducts connecting to the appliance must be suit-
ably sized for the actual air flow rate required by the
plant during operation.

3.13.2 Square ducting

- 1. Plenum connection
- 2. Square silencer

- 3. Telescopic channel
- 4. Aesthetic built-in grilles with plenum

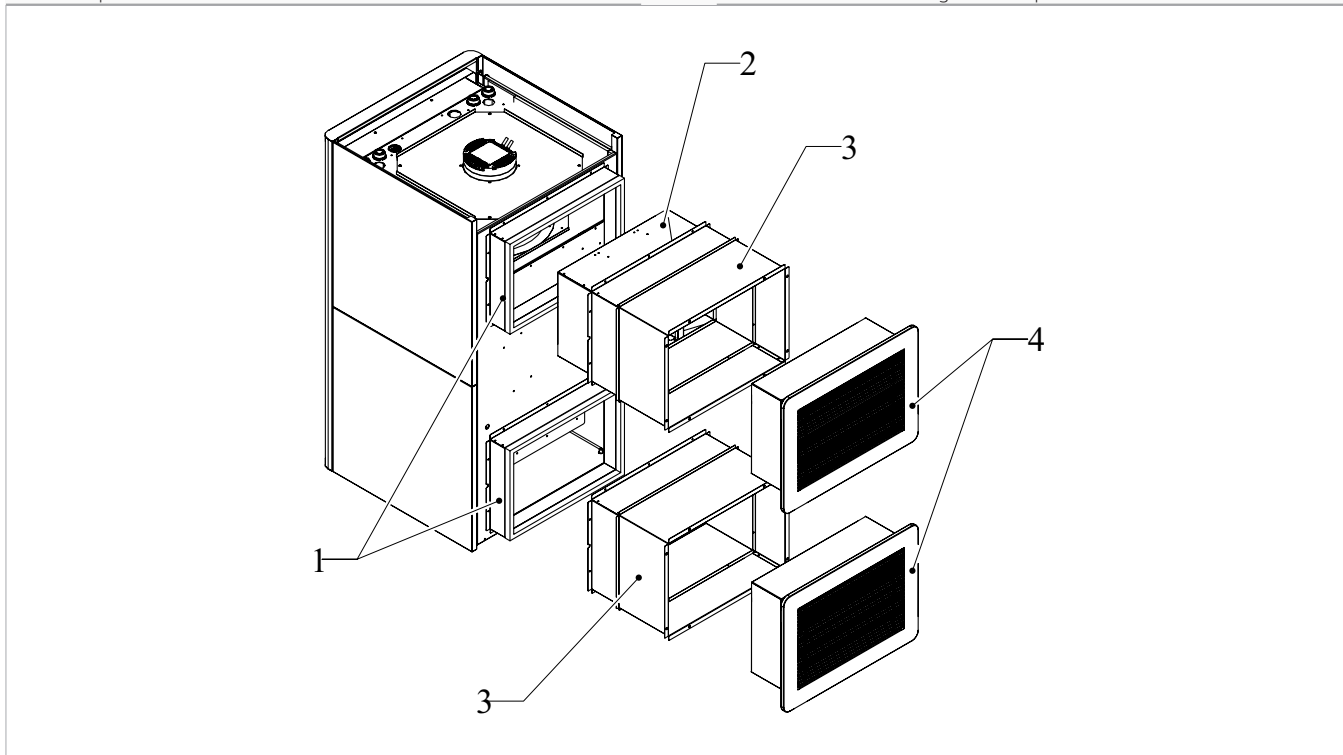

Rectangular connection

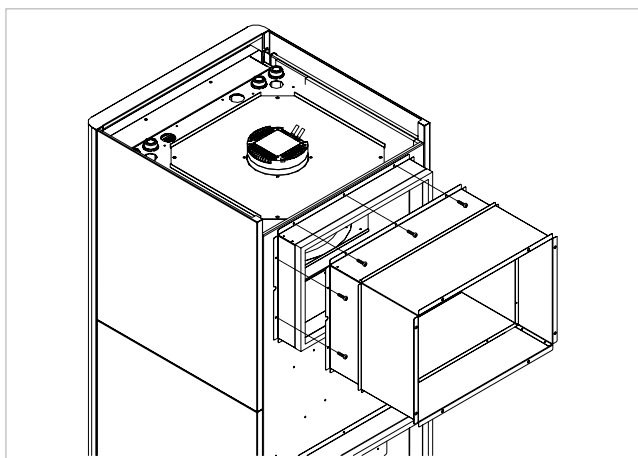

⚠ Use a duct lined with anti-condensation material of suit-
able thickness.

⚠ Please refer to chapter "Dimensions" *p. 62* for hole
dimensions.

- place the duct on the connection provided on the ap-
pliance
- fix the duct on the connection

⚠ Insert an anti-vibration coupling to prevent the trans-
mission of vibrations.

3.13.3 Circular ducting

- | | |
|--|--|
| <ol style="list-style-type: none"> 1. Plenum connection 2. Kit no. 4 rectangular/circular expulsion and intake plates 3. Ducting pipe | <ol style="list-style-type: none"> 4. Kit no. 2 silencers DN 200 mm 5. Aesthetic frames for installation of visible grilles 6. Aesthetic built-in grilles with plenum |
|--|--|

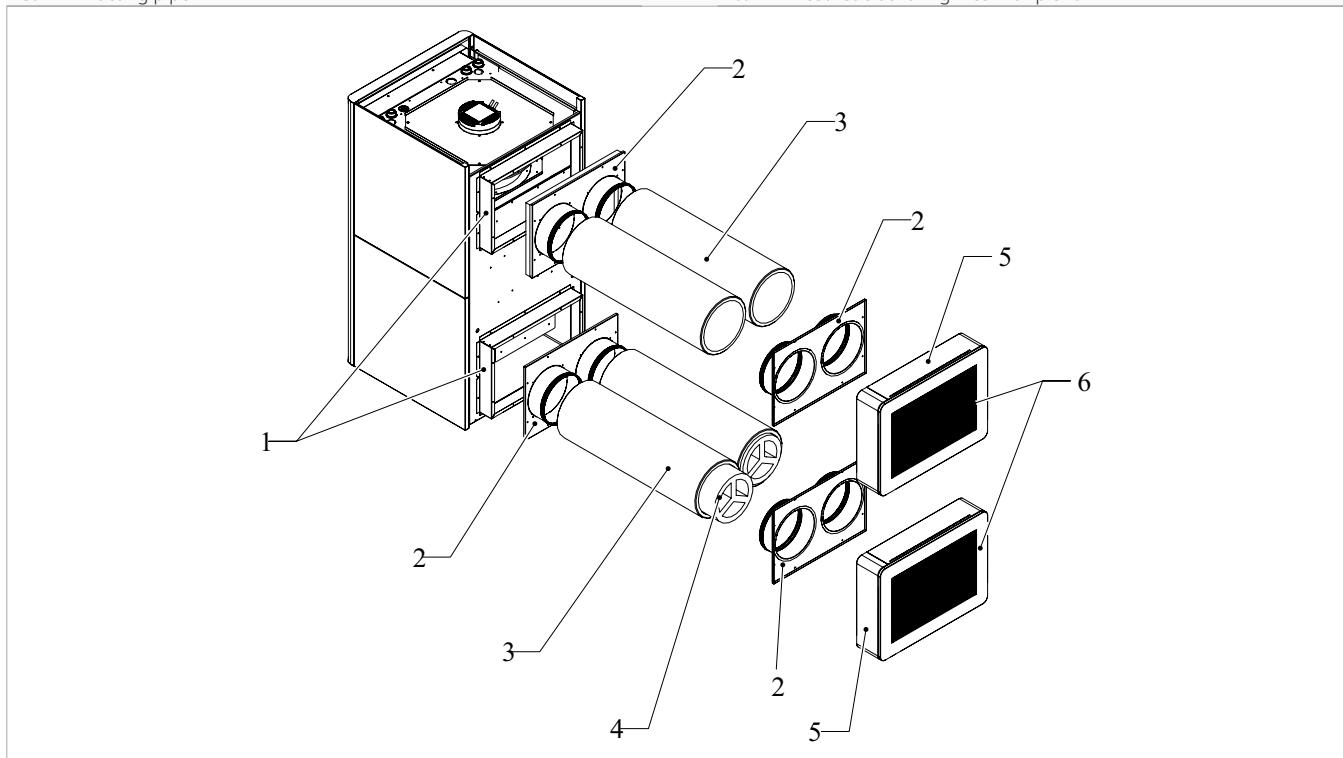

Circular connection

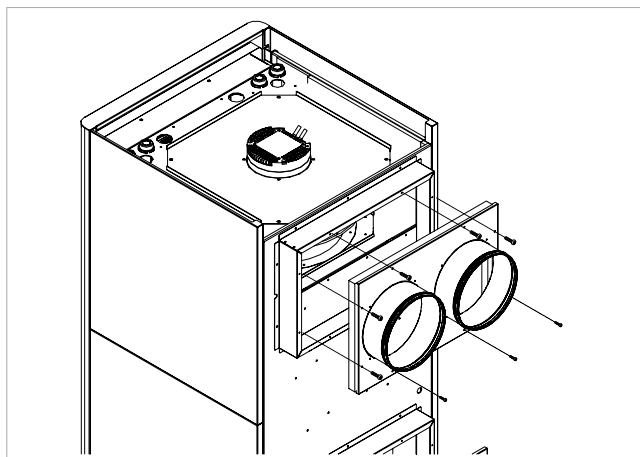

- position the ducts on the connections provided on the appliance
- use a metal tie or duct fixing clamp
- fix the ducts on the connections

- ⚠ Use a duct lined with anti-condensation material of suitable thickness.
- ⚠ Please refer to chapter "Dimensions" [p. 62](#) for hole dimensions.

3.14 Hydraulic connections

3.14.1 Preliminary warnings

- ⚠ The engineer is responsible for choosing the right water lines and their size, in accordance with good installation practices and the applicable law.
- ⚠ The hydraulic system is made by the installer and must be carried out with reference to the diagrams in this manual or on the website.
- ⚠ The hydraulic pipes connecting to the appliance must be suitably sized for the actual water flow rate required by the plant during operation. The water flow rate to the heat exchanger must always be constant.
- ⚠ The maximum permissible pressure drops must be compared with the data shown in chapter "Technical information" [p. 58](#). If higher heads are required due to high pressure drops in the plant, an external pump with respective buffer vessel must be used.
- ⚠ Make sure that the quantity of water in the primary circuit is greater than the minimum volume indicated in chapter "Plant water content and minimum flow rate" [p. 33](#), to prevent the risk of ice formation during defrosting operations or continuous modulation of the compressor frequency

- ⚠ It is important to note that the heat pump Control Panel manages all the adjustments of the primary circuit (system and domestic hot water set-point, circulation pump, dynamic set control and auxiliary heater management).
- ⚠ Any regulation that foresees the management of the plant with a control unit or a boiler conflicting with these regulations must be submitted to the manufacturer's technical office in advance for approval otherwise the warranty will be invalidated.
- ⚠ If the appliance is connected in parallel with a boiler, make sure that the temperature of the water circulating in the heat pump does not exceed 60 °C during operation.

3.14.2 Hydraulic plant

Heat pumps require plants that guarantee a constant flow of fluid to the appliance, within the minimum and maximum values and with sufficient volumes to avoid imbalances in the refrigeration circuits and to guarantee the correct level of comfort.

3.14.3 Plant water content and minimum flow rate

Water content

A minimum volume of water in the primary circuit of the plant must be guaranteed for the correct operation of the appliance.

- ⚠ The minimum volume is necessary to prevent risks of ice formation during defrosting operations or continuous modulation of the compressor frequency.

It also allows the following advantages:

- less wear and tear on the appliance

- increased system performance
- improved temperature stability and accuracy

The minimum volume is indicated in the table below:

- ⚠ If the minimum volume is not reached, a suitably sized storage tank must be provided.

- ⚠ The minimum volume must be guaranteed in all operating modes and under all conditions.

Models	m.u.	5	7
Minimum system water content	L	20	25

Minimum flow rate

To prevent the differential pressure switch from tripping, a minimum water flow rate must be guaranteed to the appliance.

The minimum flow rate must be guaranteed in all operating modes and under all conditions, if necessary by adding a by-pass valve.

A hydraulic separator must be provided if the plant requires a higher head than that available from the pump of the unit.

Models	m.u.	5	7
Minimum water flow rate	m ³ /h	0,6	0,9

3.14.4 Position and dimensions

A	S - Single version
B	SH - Version with horizontal coupling
C	SV - Version with vertical coupling
RP	System return
MP	Plant delivery

MO	Supply for DHW inside coil
RO	Return for DHW inside coil
AF	Water inlet from water supply system
AC	DHW supply for utilities

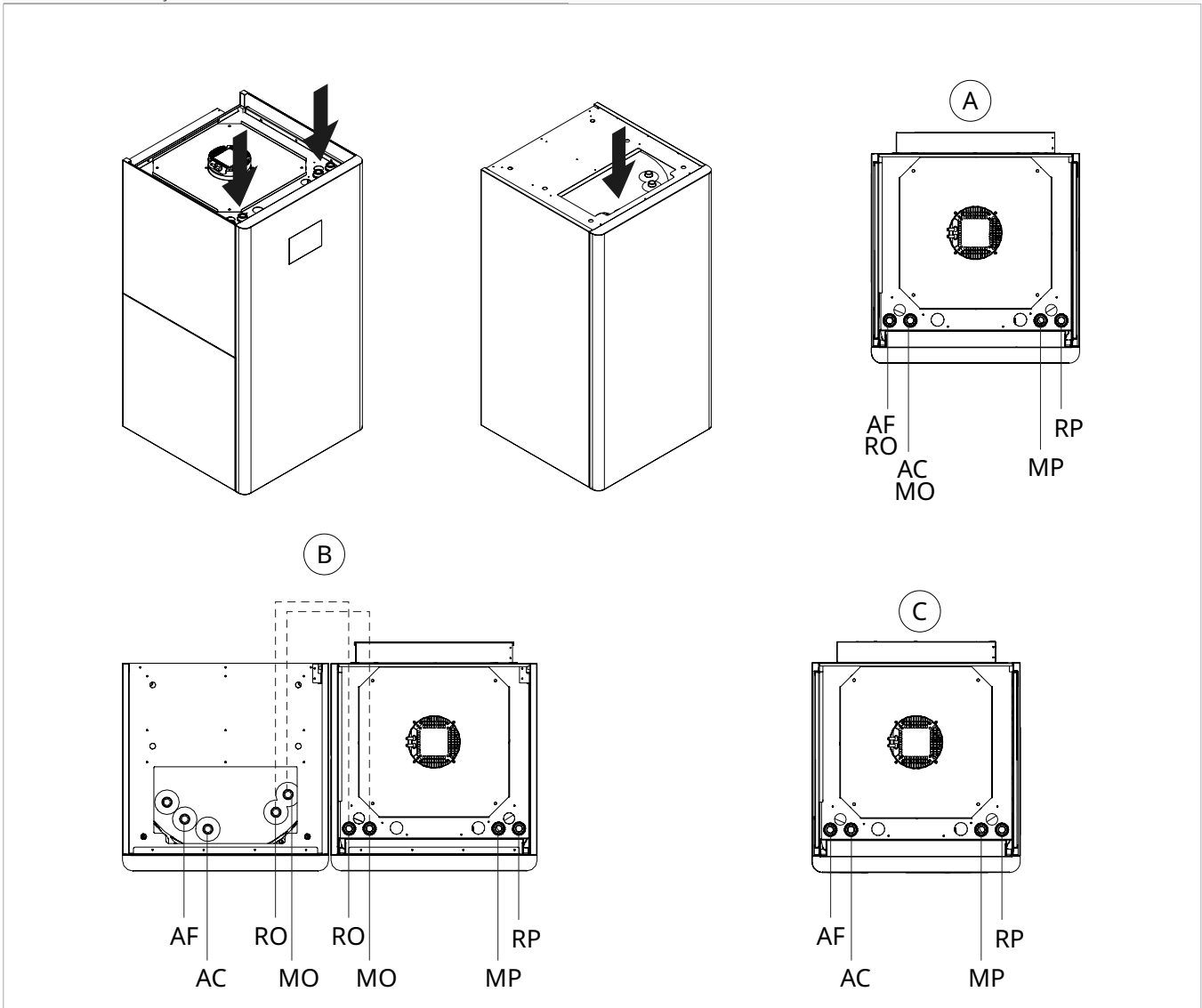

Models	m.u.	5	7
Hydraulic connections			
Plant return	" GAS	1 M	1 M
Plant delivery	" GAS	1 M	1 M
Water inlet from water supply system	" GAS	1 M	1 M
DHW supply for utilities	" GAS	1 M	1 M
Supply for DHW inside coil	" GAS	1 M	1 M
Return for DHW inside coil	GAS	1 M	1 M

⚠ For dimensional information, refer to chapter "Technical information" p. 58.

If cosmetic panels are mounted:

- remove as indicated in the chapter "Removal of aesthetic panels" p. 22

3.14.5 Connection to the system

Preliminary warnings

- ⚠ To allow maintenance or repair operations, each hydraulic connection must be equipped with the respective manual shut-off valves.
- ⚠ It is advisable to create a by-pass in the plant to be able to wash the plate exchanger without having to disconnect the appliance.
- ⚠ Before connecting the piping, make sure that it do not contain stones, sand, rust or foreign matter that could damage the plant.
- ⚠ **The minimum nominal diameter of the connecting pipes must be as indicated in the table. Keep in mind that undersized pipelines lead to poor system operation and/or a loss of thermal and cooling performance.**
- ⚠ The connection piping must be suitably supported so as not to bear on the appliance with its weight.
- ⚠ Plants filled with antifreeze or special legal provisions require the use of hydraulic disconnectors.
- ⚠ Flush the plant thoroughly before connecting the unit. This cleaning process removes any residue, such as welding drops, slag, rust or other fouling from the pipes. These substances may otherwise settle inside and cause the appliance to malfunction.
- ⚠ Hydraulic lines and joints must be thermally insulated. Insulate the water distribution piping with polyethylene foam or similar materials with a minimum thickness of 13 mm. Shut-off valves, elbows and various fittings must also be adequately insulated.
- ⚠ Avoid partial insulation of the pipes.
- ⚠ Avoid over-tightening the pipes to avoid damage to the insulation.
- ⚠ Carefully check that the insulation is tight, in order to prevent the making and dripping of condensate.
- ⚠ **Installing a dirt separator or mains water filter at the inlet of the appliance in an area accessible for maintenance is compulsory to safeguard the appliance from impurities in the water.**
- ⊖ Operating the unit without the water filter installed and clean is forbidden.

Basic hydraulic scheme

S version

A	Return to the system (RP)	3.	Plant drain cock
B	Supply to the system (MP)	4.	Flow switch (differential pressure switch)
C	Return for DHW inside coil (RO) / Water inlet from water supply system (AF)	5.	PP1 primary circulation pump
D	Supply for DHW inside coil (MO) / DHW supply for utilities (AC)	6.	Backup heating element
E	Heat pump module	7.	3-bar safety valve
F	Refrigeration circuit	8.	Sanitary diversion valve
1.	Water inlet probe	9.	System regulation probe
2.	Water outlet probe	10.	Plate exchanger

S

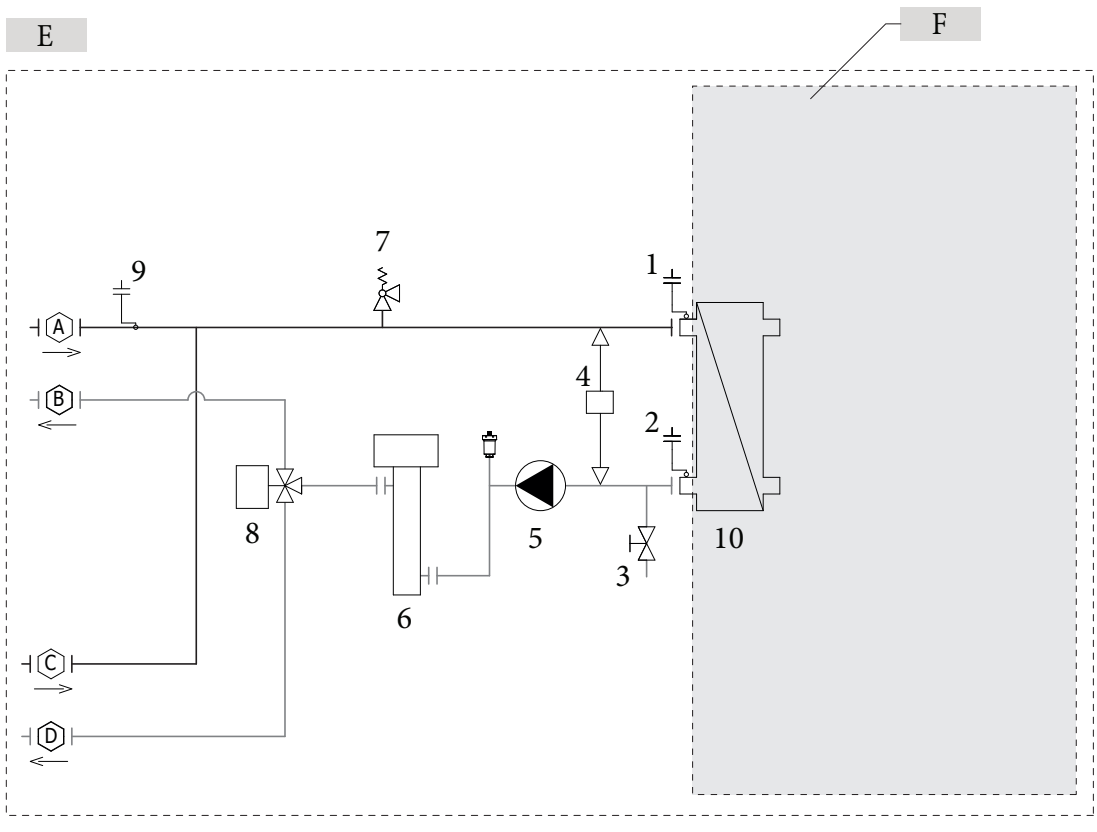
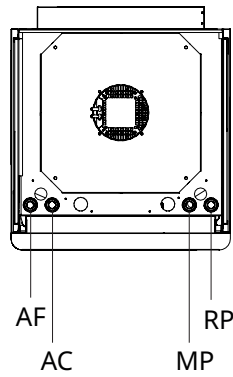

SV and SH versions

- A** Return to the system (RP)
- B** Supply to the system (MP)
- C** Return for DHW inside coil (RO)
- D** Supply for DHW inside coil (MO)
- E** Water inlet from water supply system (AF)
- F** DHW supply for utilities (AC)
- G** DHW module
- H** Heat pump module
- I** Refrigeration circuit
- 1.** Water inlet probe
- 2.** Water outlet probe
- 3.** Plant drain cock
- 4.** Flow switch (differential pressure switch)
- 5.** PP1 primary circulation pump

- 6.** Backup heating element
- 7.** 3-bar safety valve
- 8.** Sanitary diversion valve
- 9.** System regulation probe
- 10.** Pressure gauge
- 11.** Manual charging valve
- 12.** Thermostatic mixer
- 13.** Heating expansion tank
- 14.** Domestic hot water storage
- 15.** Expansion vessel for domestic hot water
- 16.** Domestic hot water probe PT4
- 17.** 6-bar safety valve
- 18.** Plate exchanger

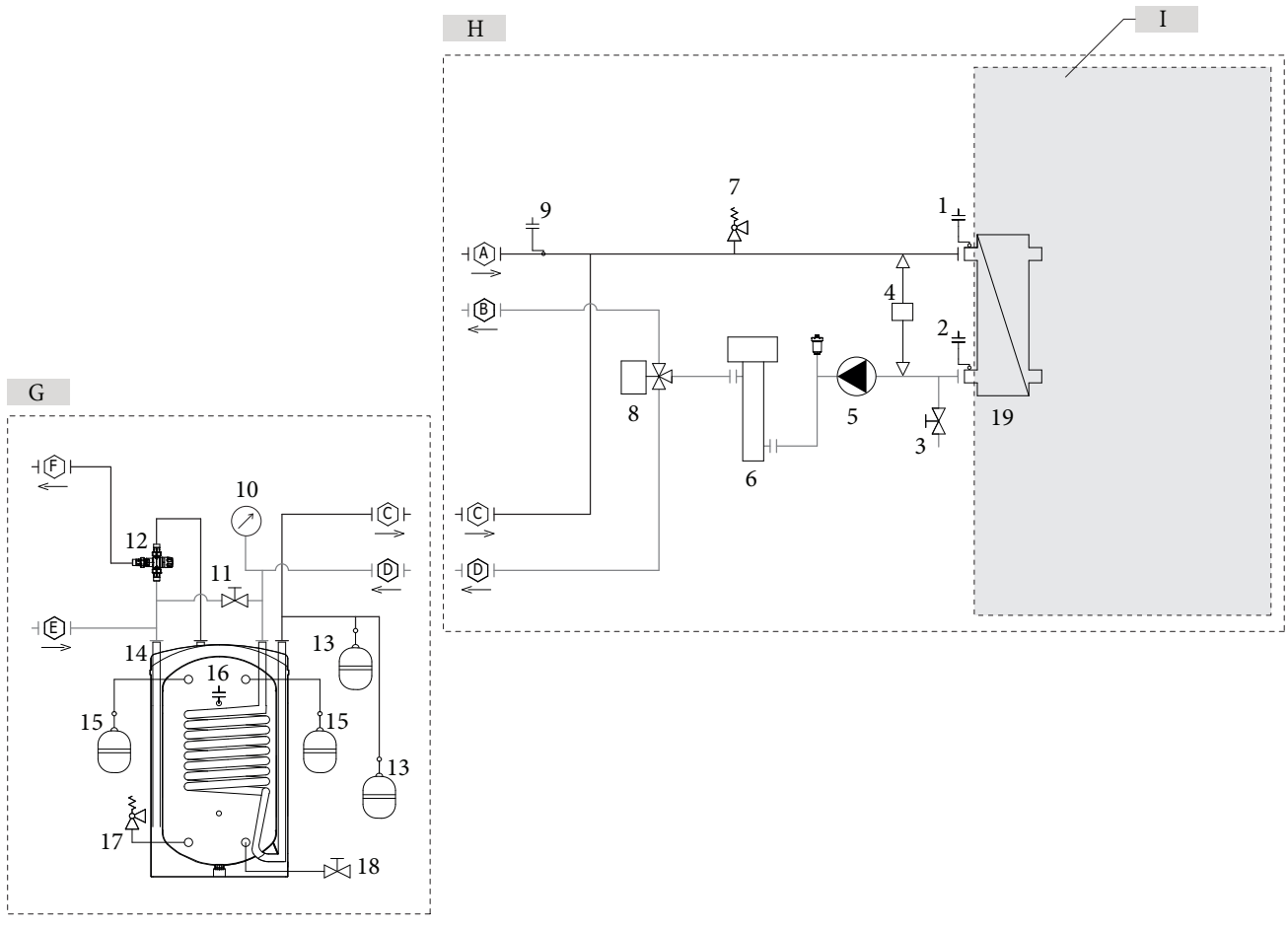
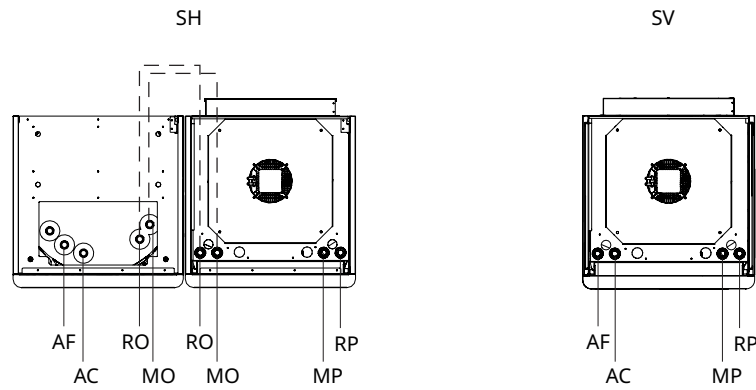

Connection diagram

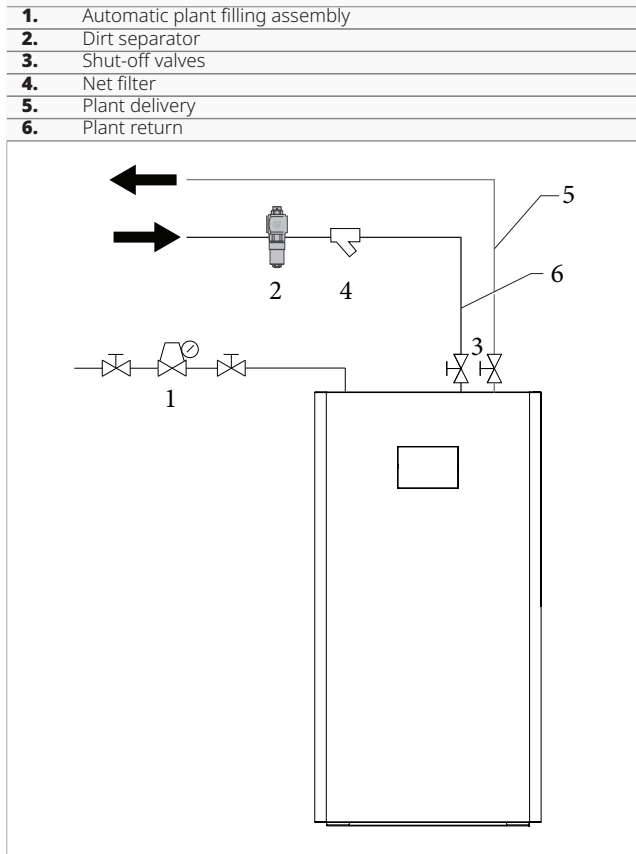

Connection

To make the connections:

- hydraulic lines positioning
- use the "wrench against wrench" method
- tighten the connections
- check for leaks

3.15 Filling the plant

The plant must be filled once the hydraulic connections have been completed.

3.15.1 Preliminary warnings

- ⚠ A filling system external to the unit must be provided.
- ⚠ All operations must be carried out with the machine stopped and disconnected from the power supply.
- ⚠ If an external auxiliary pump is used, it must be switched off.
- ⚠ The operating pressure of the plant must not exceed 1.5 bar with the pump off. To check for leaks in the plant during testing, it is advisable to raise the test pressure and then discharge it later to reach the correct working pressure. If the pressure exceeds 3 bar, the safety valve opens and discharges the excess water outside.

- coat the connections with insulating material
The hydraulic connections must be completed by installing:

- air vent valves at the highest points of the piping
- flexible elastic joints
- shut-off valves
- a suitably sized storage tank for plant water
- the secondary separator kit is available as accessory

⚠ The separator kit is compulsory unless it is already present in the system.

3.14.6 Filtration system

⚠ **It is necessary to install a filtration system at the inlet of the appliance in an area accessible for maintenance, in order to protect the appliance from impurities in the water.**

⚠ The recommended filtration system consists of a dirt separator and net filter combination to be installed outside the appliance, in the return pipe.

3.14.7 Safety valve

The outlet of the installed safety valve must be connected to a suitable collection and evacuation system to prevent any water spillage from coming into contact with the electrical parts of the appliance.

⚠ The manufacturer of the appliance is not responsible for any flooding caused by the intervention of the safety valves.

⚠ Provide a pressure reducer if the mains pressure exceeds 3 bar.

3.14.8 Air vent

To avoid air pockets inside the circuit, place automatic or manual venting devices at all points (higher piping, siphons, etc.) where air can accumulate.

3.15.2 Water quality requirements

The quality of the water used must comply with the requirements set out in the following table; otherwise, a treatment system must be provided.

Plant water reference values		
pH		6,5 ÷ 7,8
Electrical conductivity	µS/cm	250 ÷ 800
Total hardness	°F	5 ÷ 15
Total Iron	ppm	0,2
Manganese	ppm	< 0,05
Chlorides	ppm	< 250
Sulphur ions		none
Ammonia ions		none

- ⚠ Well or groundwater not coming from an aqueduct should always be carefully analysed and, if necessary, conditioned with appropriate treatment systems.
- ⚠ A water softening plant must be used if the initial water hardness exceeds the value indicated in the table.
- ⚠ An excessive water softening (total hardness < 1.5 mmol/l) could generate corrosive phenomena in contact with metallic elements (piping or parts of the boiler). Also keep the conductivity value within 600 µS/cm.
- ⚠ Check the chloride concentration at the outlet after resin regeneration.
- ⊖ Introducing acids into the washing circuit is forbidden.
- ⊖ Constantly or frequently topping up the plant is forbidden because this can damage the heat exchanger of the appliance.

3.15.3 Filling

Before starting the filling operation:

- set the plant master switch in the OFF position.

- check that the plant drain cock is closed
- open all the air valves of the plant and its terminals
- open all the system's shut-off devices

To fill the system:

- start filling by slowly opening the plant water filling cock on the outside of the appliance

When water starts coming out of the terminal vent valves:

- close the vent valves
- continue filling up to the pressure value required by the plant
- check that the expected nominal pressure has been reached
- close the water tap
- check the tightness of the gaskets

- ⚠ It is recommended to repeat this operation after the device has been running for a few hours.
- ⚠ Regularly check the system's pressure.
- ⚠ Keep the system bleed during operation, penalty, loss of performance and energy consumption.

3.16 Electric connections

The appliance leaves the factory fully wired and only needs to be connected to the power supply, Control Panel, disconnect and any accessories.

3.16.1 Preliminary warnings

- ⚠ All operations of an electrical nature must be carried out by qualified personnel having the necessary legal requirements, trained and informed about the risks related to such operations.
- ⚠ All connections must be made following the regulations in force in the country of installation.
- ⚠ Before carrying out any work, make sure that the power supply is switched off.
- ⚠ The unit must only be powered after all plumbing and electrical work has been completed.
- ⚠ References:
 - refer to the wiring diagrams in this manual for the electrical connections, especially the part concerning the power supply terminal block
 - refer to the technical rating plate located on the appliance for the power supply voltage
- ⚠ Make sure that:
 - the characteristics of the electric network are adapted to the absorption of the apparatus, considering also any other devices in parallel operation
 - the power supply voltage and system frequency match to the values indicated on the device's plate data
 - the cables must be appropriate for the type of installation in accordance with the applicable IEC standards
 - the cable terminals are provided with pin terminals of a cross-section proportionate to the connecting cables before inserting them into the terminal block
 - the power supply is provided with protection against overload and/or short-circuit
- ⚠ It is required:

- connect the device an efficient ground connection
- for units with three-phase power supply, check that the phases are connected correctly

- ⚠ It must be possible to disconnect the power supply line from the rest of the electrical network of the building using an omnipolar magneto-thermal circuit breaker complying with EN 60335 part 1 (contact opening of at least 3 mm), suitable for the draw of the appliance, with differential relay with the maximum setting as prescribed by the individual electrical regulations.
- ⚠ Do not connect the appliance to earth using distribution piping, surge arresters or to the telephone plant earth. Improper earthing can result in electric shock. Momentary high-voltage surges caused by lightning or other causes could damage the heat pump.
- ⚠ It is recommended to install a residual-current device. Failure to install this device may result in electric shock.
- ⚠ Electrical connections must be made following the instructions in this manual and with the standards or practices governing the connection of electrical equipment throughout the country. Insufficient capacity or incomplete electrical connections may result in electric shock or fire.
- ⚠ The power supply line must be adequately sized to avoid voltage drops or overheating of cables or other devices placed on the line itself.
- ⚠ Use a dedicated power circuit. Never use a power supply to which another appliance is also connected because of the risk of overheating, electric shock or fire.
- ⚠ For the electrical connection, use a cable that is long enough to cover the entire distance without any connection. Do not use extension cables. Do not apply other loads on the power supply.

- ⚠ After connecting the interconnection and power cables, make sure that the cables are routed so that they do not apply excessive forces on the covers or electrical panels. Incomplete connection of the covers may result in overheating of the terminals, electric shock or fire.
- ⚠ If you need to replace the power cable, contact only qualified staff and in compliance with the applicable national laws.
- ⚠ The manufacturer is not liable for any damage caused by the lack of earthing or failure to comply with the specifications in the respective diagrams.
- ⚠ The device is equipped with suppression filter as laid down by the applicable laws and standards. Use selective circuit breakers to compensate for the micro-dispersion on the ground of this device.
- ⊖ It is forbidden the use of gas and water pipes for grounding the appliance.

- ⚠ Do not place flammable objects (spray cans) within 1 metre of the air outlet.
- ⚠ All precautions concerning the treatment of the refrigerant must be observed following the regulations in force.
- ⚠ Avoid proximity to sources of ignition in continuous operation (open flames, gas appliances, electric stoves, lighted cigarettes, etc.).
- ⊖ Smoking in the vicinity of the appliance is prohibited.
- ⊖ Using a mobile phone near the appliance is prohibited.
- ⚠ Perform the following checks:
 - carry out safety checks to ensure that the risk of combustion is minimised
 - avoid working in confined spaces
 - delimit the area around the workspace
 - ensure safe working conditions around the area by controlling flammable material

Preliminary warnings for R32

- ⚠ R32 refrigerant gas is slightly flammable and odourless.

3.16.2 Power line dimensioning

Use the tables below for the sizing of the power supply line and its protection device. These are not average draw or transient peaks, but values to be considered for the correct sizing of the plant and the request of the contractual power (excluding loads due to the normal operation of the building).

- ⚠ Maximum power is reached only in exceptional cases. Therefore, the indicated trip current is suggested to guarantee a balance between machine absorption and incidence in the general system.
- ⚠ The indicated minimum cable cross-section area must be verified according to the actual conditions of the installation: length of the cable, characteristics of the electrical supply, etc.

Models	m.u.	5	7
Electrical data			
Power Supply	V/ph/Hz	230/1/50	230/1/50
Maximum absorbed power	kW	3,80	4,10
Maximum absorbed current	A	14,00	19,00
Protection tripping current	A	16	16
Minimum wire cross-section area	mm ²	4,0	4,0

- ⚠ **For units equipped with electrical heating elements, the draw values of the units must be added to those of the heating elements shown in the following tables.**

Heating elements

Connection		Single stage
Power draw	kW	2,00
Current draw	A	8,70

3.16.3 Access to the electrical panel

1. Connection entry
2. Control Panel

3. Connection terminal blocks

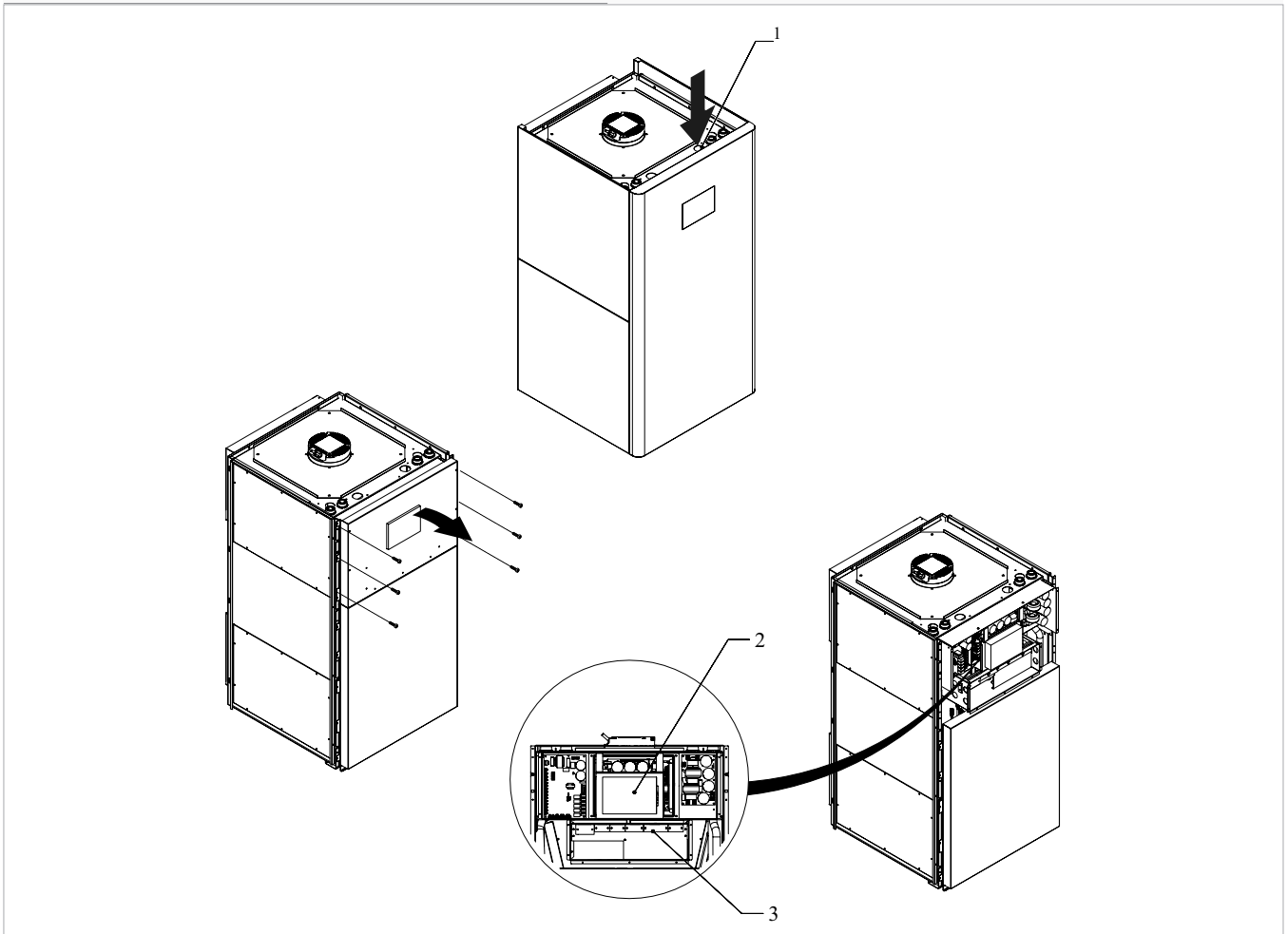

⚠ Access to the electrical panel is only permitted to qualified personnel.

⚠ Before doing any work, make sure that the supply power is disconnect.

To access:

- remove the cosmetic panels (if fitted)
- see chapter "Disassembly and assembly of cosmetic panels after installation" [p. 45](#)

To access the connections:

- undo the screws of the closing panel of the electric panel
- remove the panel

3.16.4 Connection

⚠ **Before connecting the unit to the mains power supply, make sure that the disconnecter is open. The power supply of the unit must be connected to the appropriate terminals, subject to the action of the disconnecter.**

⚠ Use properly sized cables to avoid voltage drops or overheating.

⚠ Before connecting to the terminals, read this manual carefully.

Connection diagram

1.	Unit power supply 230/1/50	5.	Protection switch
2.	Protection switch (by installer)	6.	Emergency heating element power supply
3.	Power cable	A	Connection of electrical resistance
4.	Unit		

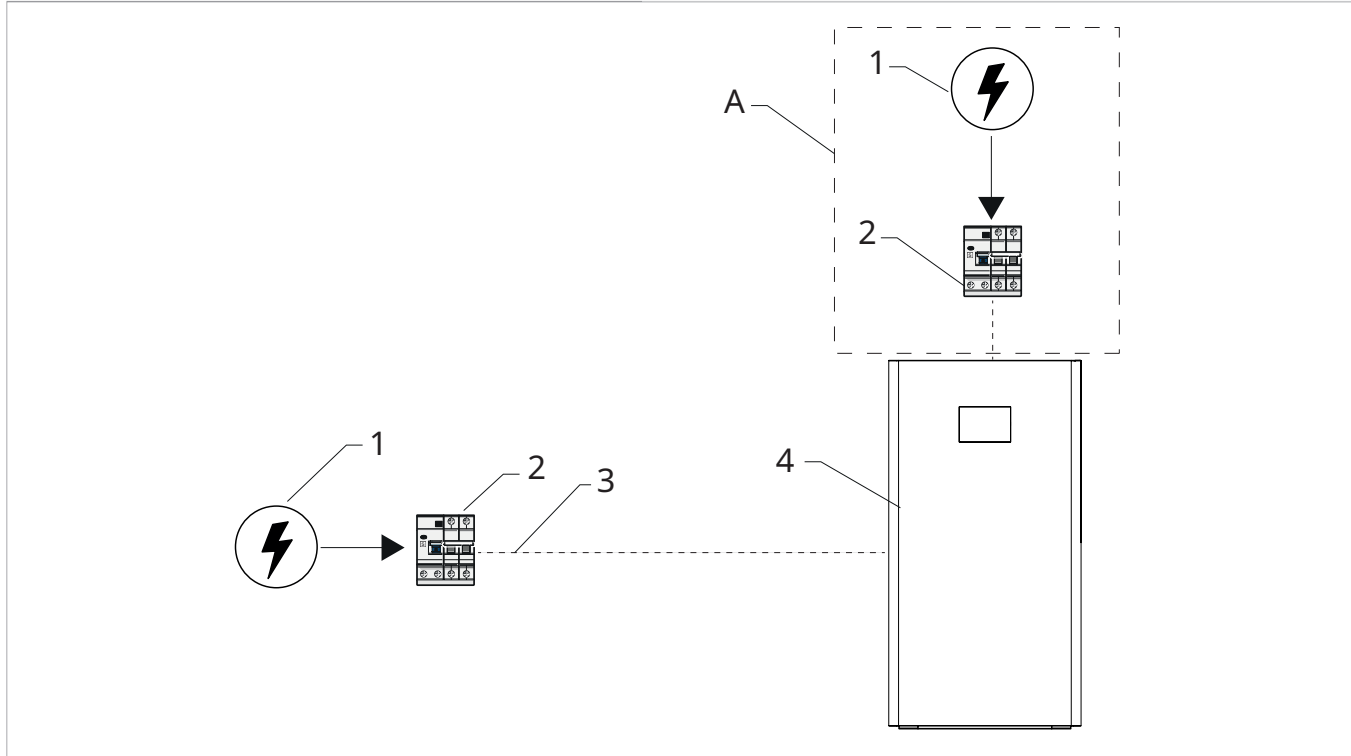

Electrical panel aboard the unit

Power connection terminal blocks

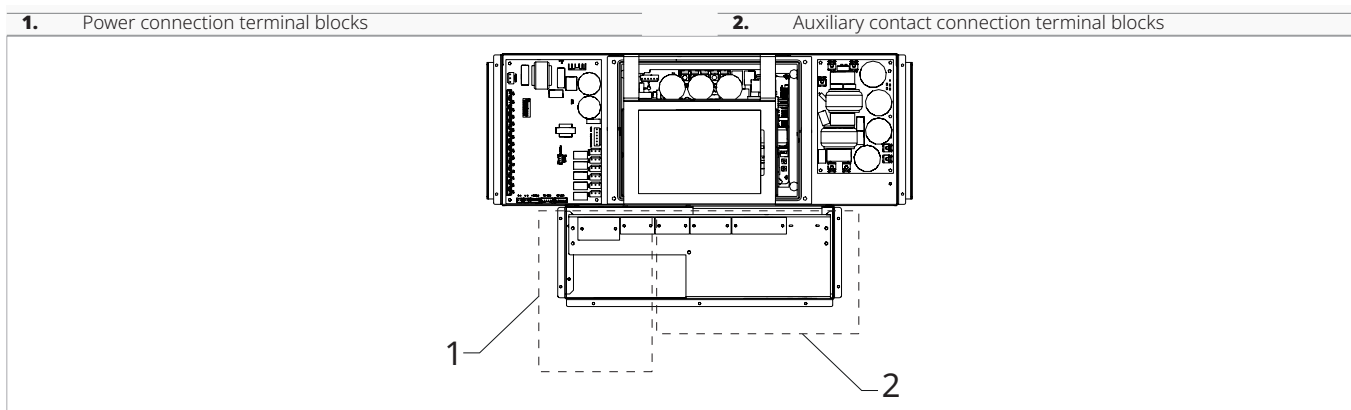

To make the connection:

- bring the power cord to the terminal block
- making the connections
- refer to the information in the wiring diagram of the unit you are installing

⚠ The power cable must be sized according to this manual.

⚠ Use a double-insulated multi-core cable mod. H07RNF for outdoor applications in cable duct, or mod. H05VVF for indoor applications.

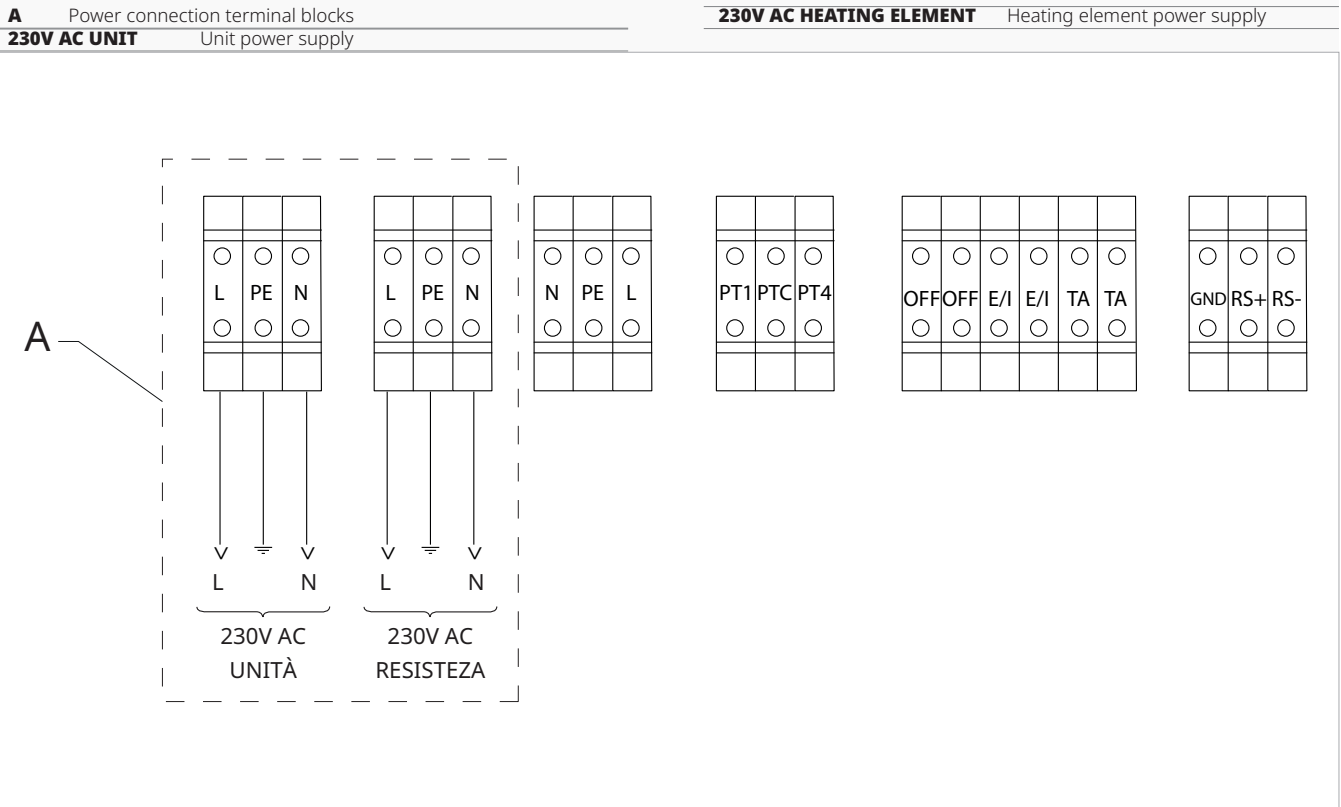

Auxiliary contact connection terminal block

<p>A Auxiliary contact connection terminal blocks</p> <p>PP3 Secondary circulation pump PP3 power supply</p> <p>PT1 Plant temperature probe</p> <p>PTC Probe connection common</p> <p>PT4 Domestic hot water tank temperature probe</p>	<p>PI5 Remote On/Off</p> <p>PI4 Silent or Heating/Cooling switching</p> <p>PI3 Consent from room thermostat or generic voltage-free contact</p> <p>Modbus Modbus connection</p>
--	---

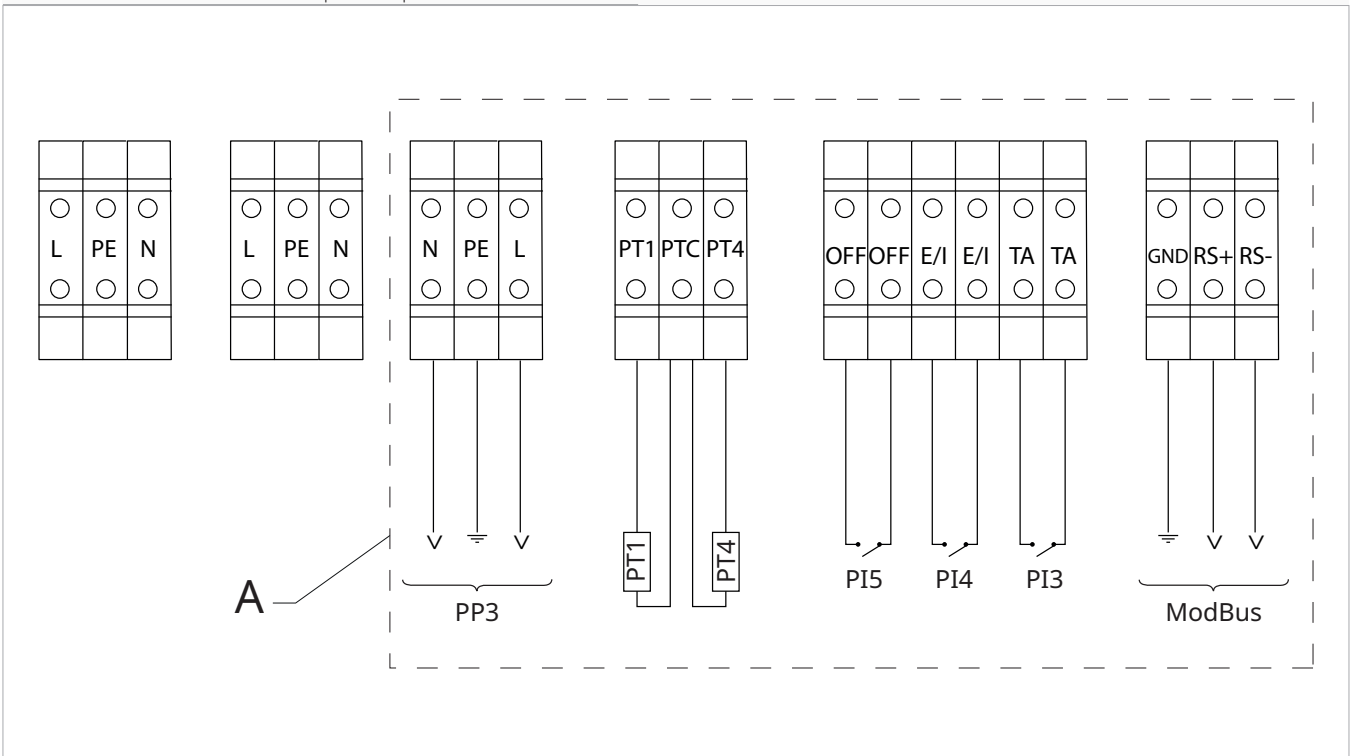

Description of auxiliary contacts

Relay output terminals

N - L: PP3 Secondary pump connection 230 V max 1 A.

Probe terminals

PT1 - PTC: connection of plant temperature probe PT1.

PT4 - PTC: connection of domestic hot water tank temperature probe PT4.

The probes are supplied with the unit. Place the probe to be used in a suitable sump on the relevant tank (maximum distance of 5 m).

Digital input terminals

OFF - OFF: PI5 contact for remote activation/deactivation of the appliance.

- Operation must be active by parameter **PF4** (see Control Panel manual)

E/I - E/I: PI4 configurable input for activating/deactivating the Silent function or for switching the Cooling/Heating operating mode. The Silent function reduces the noise level of the appliance by lowering the working frequency of the compressor and the fan.

- Operation must be activated by parameter **PF5** (see Control Panel manual).

TA - TA: PI3 TA consent from room thermostat or generic potential-free contact.

- Closed contact: the unit is switched on for heating or cooling the plant water.
- Open contact: the unit is switched off for heating or cooling the plant water.

⚠ If the domestic hot water function is active, this function has priority even when the contact is open.

⚠ The terminals are supplied jumped (contact closed). Remove the jumper to connect the TA consent.

Power and communication terminals

RS+ - RS-: Modbus connection for control with external supervisor.

3.17 Disassembly and assembly of cosmetic panels after installation

3.17.1 Removing covering elements

Heat pump module

- 1. Front panel
- 2. Upper cover (only for SH versions)

- 3. Access panel

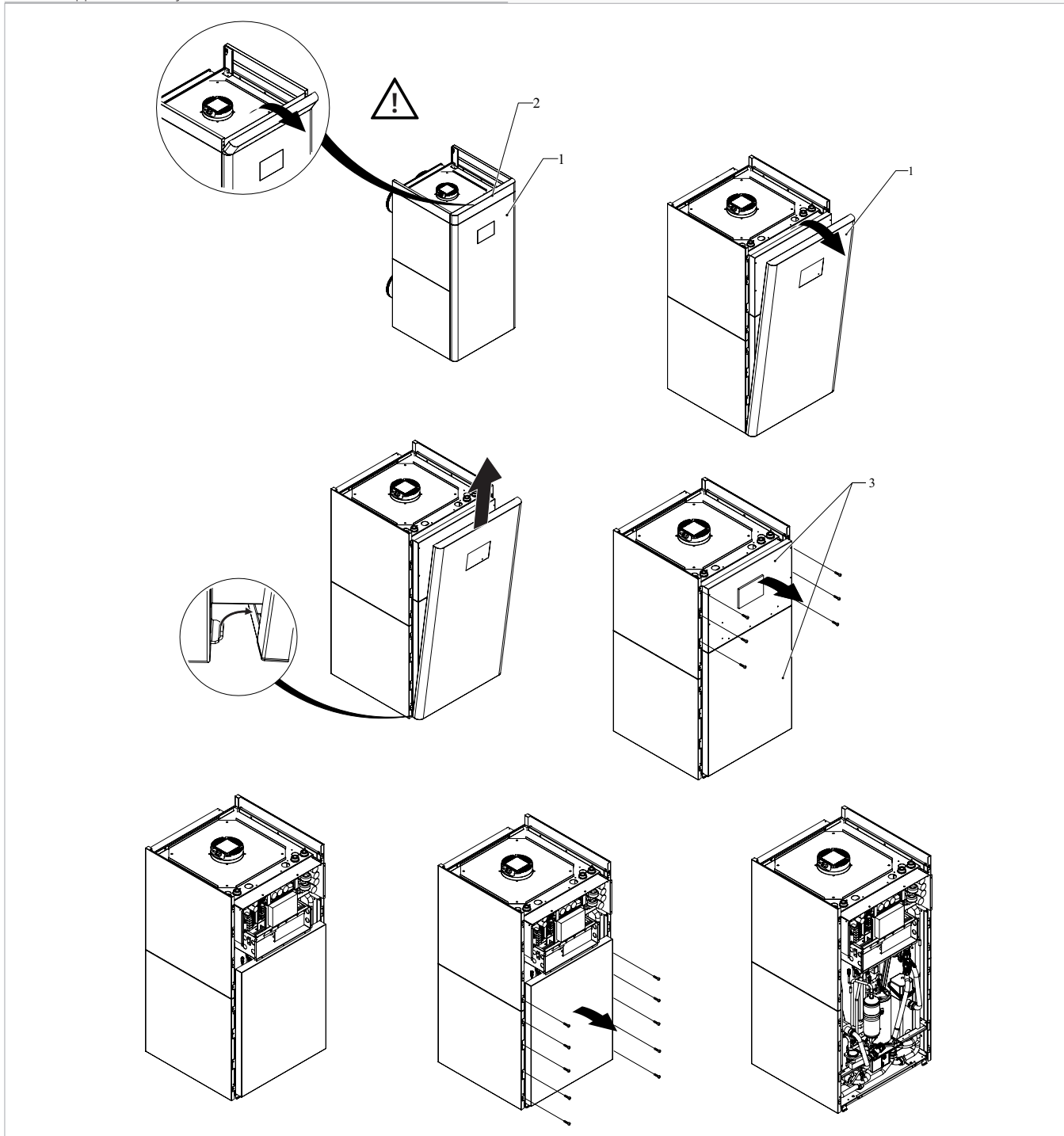

⚠ Top covering available only for the SH version.

Removing panels

- remove top covering (only for SH version)
- open the front panel by turning it downwards
- remove the aesthetic front panel

- Unscrew the access panel fixing screws
- remove the access panel

Access to internal components

DHW module

1. Front panel

2. Top covering (only for SH version)

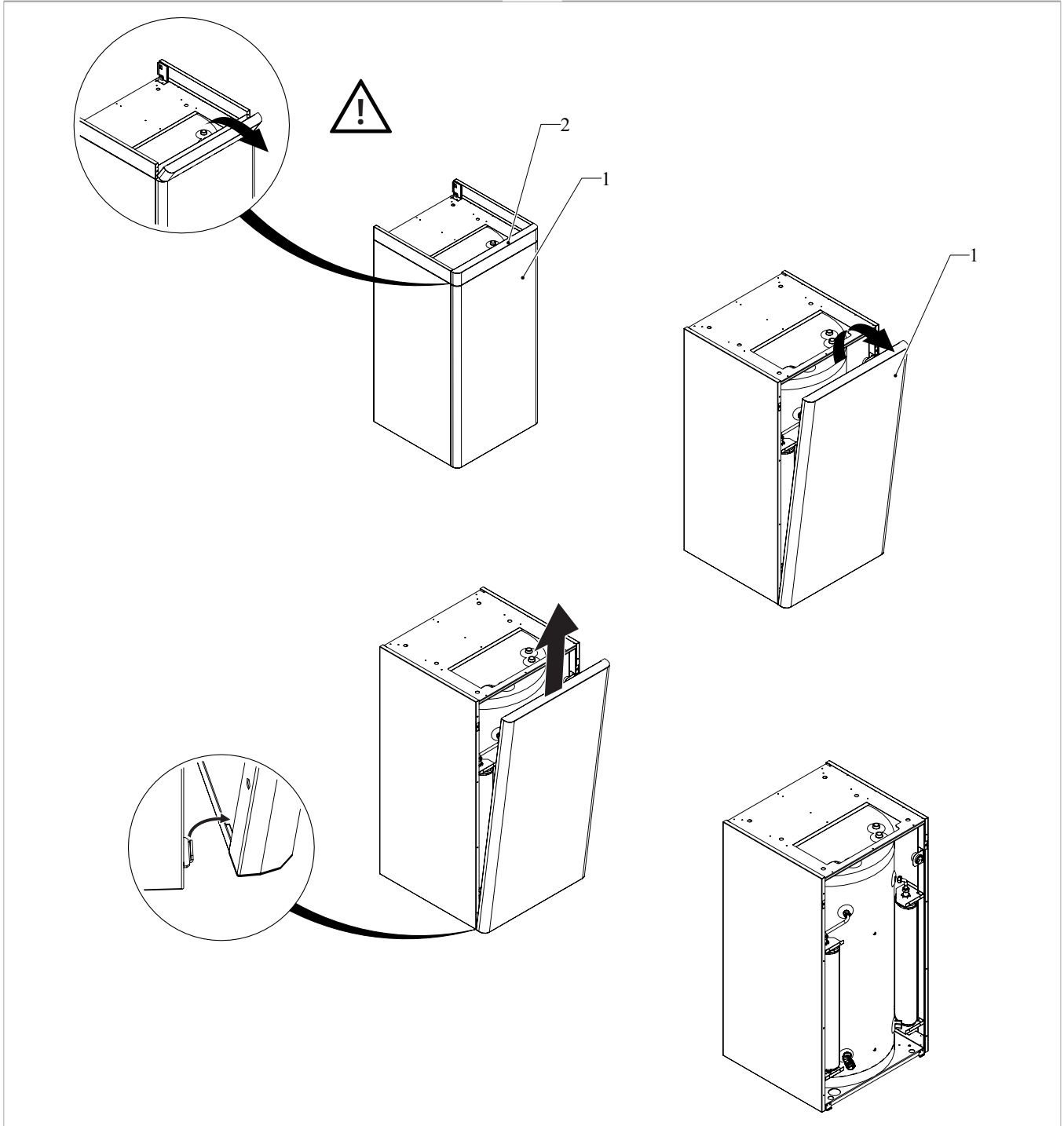

 Top covering available only for the SH version.

Removing panels

- remove top covering (only for SH version)
- open the front panel by turning it downwards
- remove the aesthetic front panel

3.17.2 Fitting of covering elements

Heat pump module

1. Front panel

2. Upper cover (only for SH versions)

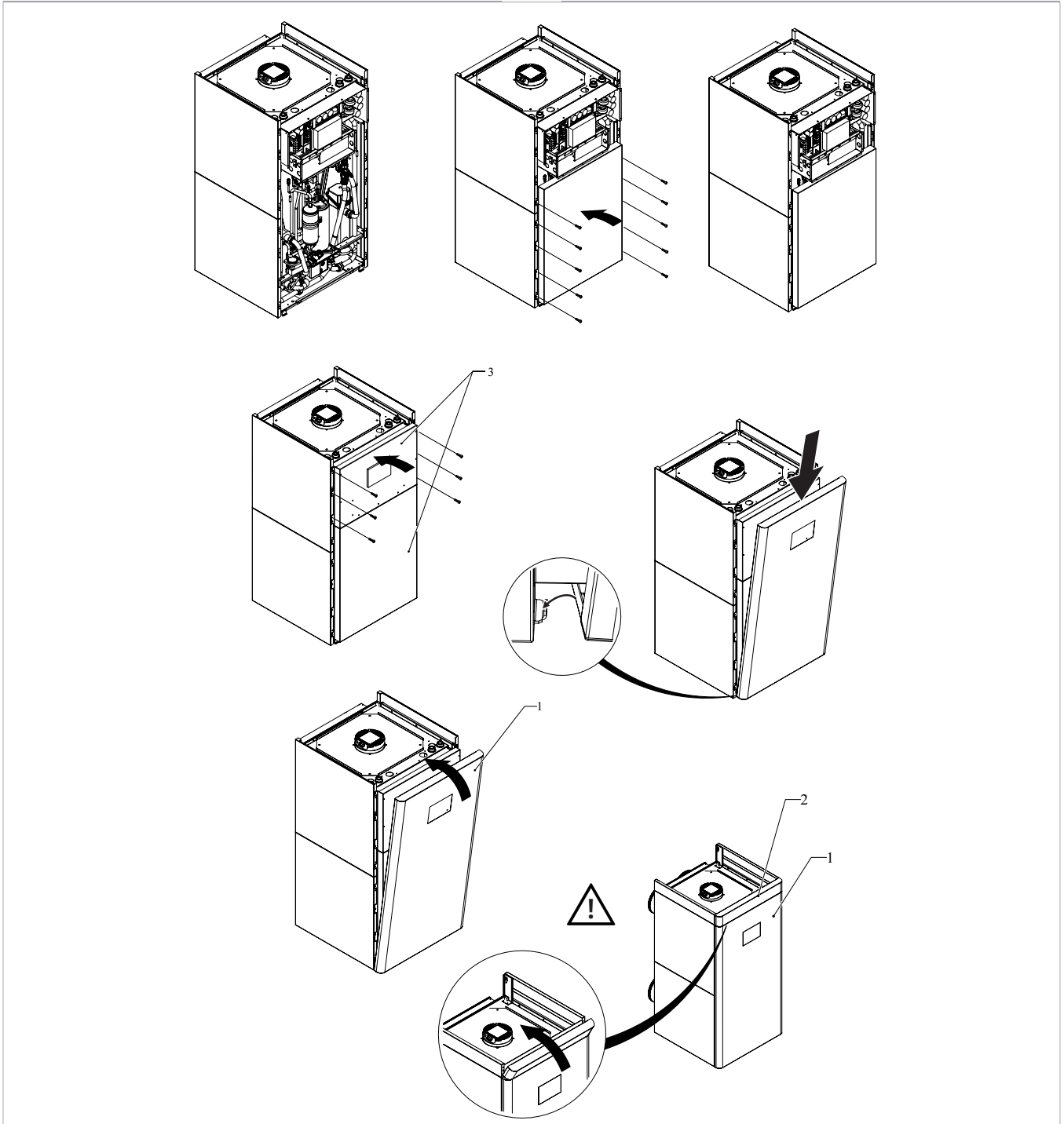

⚠ Top covering available only for the SH version.

Internal components

- close the access panel to internal components
- fix with screws

Mounting panels

- bring the front panel closer
- hook the lower part
- close the front panel
- position the top covering (only for SH version)

DHW module

1. Front panel

2. Upper cover (only for SH versions)

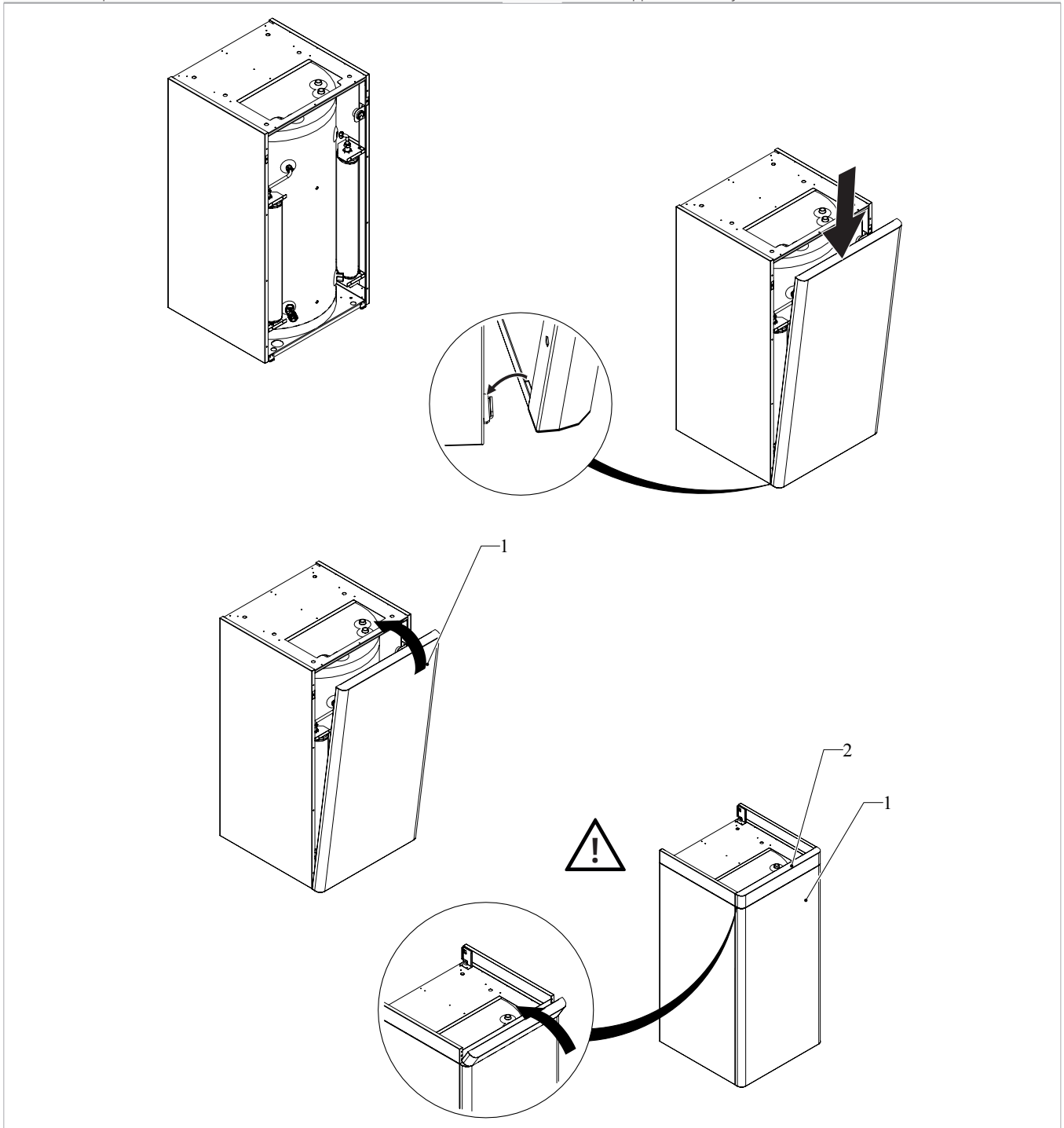

 Top covering available only for the SH version.

Mounting panels

- bring the front panel closer
- hook the lower part
- close the front panel
- position the top covering (only for SH version)

PUTTING IT INTO SERVICE

4.1 Preliminary warnings

- ⚠ **This section is dedicated to the Technical Service Assistance. The features of the Technical Service Assistance are described in chapter "Recipients" p. 6.**
- ⚠ **The initial start-up of the heat pump must be carried out by the Service Centre.**
- ⚠ The customer must be present when the appliance is tested and informed of the contents of the manual and procedures. After commissioning, the manual and the warranty certificate must be handed over to the customer.
- ⚠ Before start-up, all work (electrical and plumbing connections, filling and venting of air from the plant) must be completed.

4.1.1 Preliminary warnings for R32

- ⚠ The unit uses environmentally friendly R32 refrigerant gas, with a Global Warming Potential (GWP) = 675. Do not release R32 gas into the atmosphere.
- ⚠ R32 refrigerant gas is slightly flammable and odourless.
- ⚠ All precautions concerning the treatment of the refrigerant must be observed following the regulations in force.
- ⚠ Avoid proximity to sources of ignition in continuous operation (open flames, gas appliances, electric stoves, lighted cigarettes, etc.).
- ⊖ It is forbidden to use means to accelerate the defrosting process or for cleaning other than those recommended.

- ⊖ Smoking in the vicinity of the appliance is prohibited.
- ⊖ Using a mobile phone near the appliance is prohibited.
- ⚠ Perform the following checks:
 - carry out safety checks to ensure that the risk of combustion is minimised
 - avoid working in confined spaces
 - delimit the area around the workspace
 - ensure safe working conditions around the area by controlling flammable material

Leak detection

- ⊖ The use of combustion fluid detectors, e.g. a halide torch or other detection system using an open flame, is forbidden.
- ⚠ Follow the instructions below for leak detection:
 - use electronic detectors to detect flammable refrigerants
 - check that the detectors are properly calibrated before use
 - calibration operations must be carried out in an area free from refrigerant
 - make sure that the detector is not a potential source of combustion and that it is suitable for the refrigerant used
 - all open flames must be removed if a leak is suspected
 - in the event of a leak requiring brazing, it is mandatory to recover all the refrigerant from the system or isolate it (by means of shut-off valves) in a part of the system away from the leak
- ⚠ The use of silicone sealant may affect the effectiveness of some types of leak detectors.

4.2 First start-up

4.2.1 Preliminary checks

Before proceeding with start-up, check that:

Functional

- all safety conditions have been met
- the unit has been properly secured to the supporting surface or wall
- the minimum technical clearances have been respected

Hydraulics

- the hydraulic connections have been made according to the instructions in the manual
- the hydraulic plant has been filled and vented
- the loading tap is closed
- the shut-off valves of the hydraulic circuit are open
- the mesh filter is installed and clean

- ⊖ Operating the unit without the water filter installed and clean is forbidden.

Electrics

- the cross-section of the power supply cables is suitable for the absorption of the appliance and the length of the connection made
- the earthing was performed correctly
- the electrical connections have been established correctly
- all electrical connections are properly secured and all terminals properly tightened
- the voltage is within a tolerance of 10% of the rated voltage of the unit
- the power supply of the three-phase models has a maximum unbalance between phases of 3%

- all control wires are connected and all electrical connections are firmly in place
- the control panel has been installed and connected correctly

Refrigeration

- the refrigerant connections have been made according to the instructions in the manual
- the hydraulic circuit interception valves are open

4.2.2 Water quality checks

The technician must measure the reference values of the water in the system with special test kits.

- ⚠ Take the necessary steps to achieve the indicated limits if the total hardness is greater than 15 °F or some top-up water reference values are not within the limits indicated.
- ⚠ Water from wells or groundwater that is not from an aqueduct should always be carefully analysed. If necessary, condition with appropriate treatment systems.
- ⚠ If a softener is installed, in addition to following the manufacturer's instructions, adjust the outlet water hardness to not less than 5 °F (by performing pH and salinity tests) and check the outlet chloride concentration after adjusting the resins.

4.2.3 Powering up

⚠ **Power up the unit for at least 12 hours before starting.**

⚠ Make sure that the control panel is switched off.
Start the unit:

- set the main switch to ON

The display will light up a few seconds after power-up, check that the operating status is OFF. Otherwise, press the  button to put it in Standby.

⚠ **Refer to the Control Panel Manual for operation.**

4.2.4 Start-up

Once all checks have been made, the unit can be started up.

To activate the device

- press the key 
The symbol  or  lights up

Functional checks:

- verify the different modes of operation
- check that the appliance performs a shutdown and subsequent restart
- switch the appliance off and on again and check that it restarts correctly
- ⚠ Carry out the measurements indicated on the Test Sheet for the first start-up.
- ⚠ Refer to the Control Panel Manual to carry out the operations.
- ⚠ During start-up, the primary pump must be operated in fixed speed mode set at maximum speed (factory setting).
- ⚠ The first start-up must be carried out with standard settings. Only after the test has been completed, change the operating set point values.

Intervention ALRM 017

If the alarm ALRM 017 appears after the start-up of the circulation pump, check that

- the plant valves are open
- there is at least one consumer with an open circuit
- the mesh filter is not clogged
- there are no air bubbles inside the circuit
- the water pressure of the plant is correct

If necessary, rearm the alarm.

4.2.5 Checks with the machine switched on

After starting up, check that

Functional

- the appliance operates within the recommended operating conditions (see technical specifications table) the circulation pump is running and the water flow rate is sufficient to close the contact of the differential pressure switch
- the water supply is correct (see chapter "Thermal gradient" [p. 50](#))
- the differential pressure switch is functioning correctly

Electrics

- the current draw of the compressor is lower than the maximum indicated in the technical specifications table
- the supply voltage value is within the set limits and does not fall below the nominal value during compressor operation -10 %
- in models with three-phase power supply, the compressor noise level is not abnormal
- the three-phase supply has a maximum unbalance between phases of 3%

Hydraulics

- the hydraulic circuit is completely deaerated (see chapter "Presence of air" [p. 50](#))

Thermal gradient

The temperature difference must be verified with:

- 100% compressor capacity
- all distribution valves open
- all consumers on
- any secondary pumps in operation switched on and calibrated

Check that the thermal gradient between the plant delivery and return is between 4-7°C by querying parameters PT5-S and PT6-S.

If the temperature difference is less than 4 °C, set a lower circulator speed, see chapter "PP1 primary circulation pump" [p. 51](#).

If the thermal gradient is greater than 7 °C check that all the valves on the plant are open and if necessary add an external pump to increase the water flow rate.

If the mains pressure exceeds 3 bar, install a pressure reducer on the filling line.

Presence of air

Check that no air pockets are still present once the electrical connections have been established and the circulation pump has been switched on.

In the presence of air pockets:

- stop the pump several times
- vent again

⚠ To avoid dangerous cavitation that could damage the pump and make the entire appliance less efficient, the suction pressure, with the pump on, measured by the pressure gauge on the appliance, must not be less than 0.6 bar.

⚠ **Failure to vent, or not venting completely, could result in failure of the circulation pump.**

4.3 Adjustments

4.3.1 Setting the head value

The setting of the maximum head value should be carried out after calculating the pressure losses of the circuit and the utilisations with.

- 100% compressor capacity
- all distribution valves open
- all consumers on

4.4 PP1 primary circulation pump

The appliance uses a high-efficiency wet circulation pump, suitable for all heating and air-conditioning plants.

On the front of the pump body there is a regulator for select operating mode at fixed or variable speed:

⚠ **Fixed speed mode must be used for the primary pump.**

4.4.1 Fixed speed mode

In this mode, the circulation pump operates at fixed speeds that are not subject to regulation. For operating curves (available at maximum speed) see chapter "PP1 circulation pump graphs" [p. 66](#).



⚠ The unit is supplied with the selector set to maximum speed.

There are two different control modes according to the installed pump model:

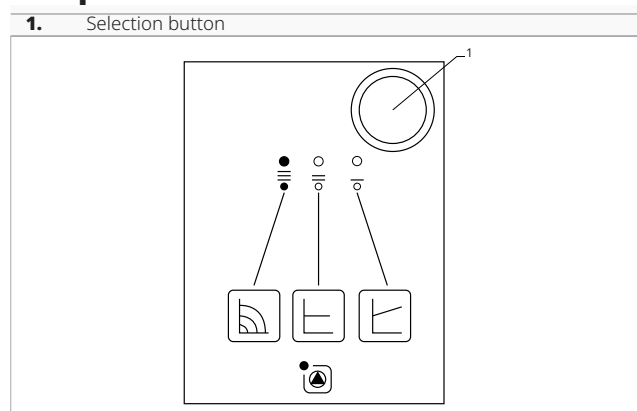
Pump model 2



To select maximum speed:
– press the selection button in sequence until the LEDs light up

-  Fixed speed selection
-  Maximum speed

4.5 Plant delivery

Once all the checks and controls on the correct operation of the plant have been completed, the installer must explain the following to the user:

- the basic functional characteristics of the appliance
- the instructions for use
- the routine maintenance

4.6 Long period shut-down

The following operations must be carried out if the air-to-water heat pump is not used for a long time:

- disable the device
- turn the master switch of the appliance to position 0-, OFF.

After switching off the appliance:

- switch off the indoor terminal units by setting the switch of each appliance to the "off" position
- set the main system switch to "Off"
- close the water taps

⚠ If the outside temperature may fall below zero degrees centigrade, with the likelihood of frost, the hydraulic plant must be drained or antifreeze liquid (e.g. ethylene glycol) must be added in the doses recommended by the manufacturer.

To restart the heat pump after it has been out of operation for a long time, contact the Service Centre.

4.7 Draining the plant

The appliances are equipped with a drain cock, it is necessary to provide one on a pipe connecting to the plant at a point near and below the appliance.

4.7.1 Preliminary warnings

⚠ All operations must be carried out with the machine stopped and disconnected from the power supply.

4.7.2 Draining

Before starting the emptying operation:

- set the main system switch to "Off"
- check that the plant water filling/top-up cock is closed

To drain the plant:

- open the water drain tap in the bottom left of the hot water tank
- Open the manual vent on the top of the hot water tank

⚠ If the system is fitted with antifreeze, the liquid must not be discharged freely because it is polluting.

MAINTENANCE

Routine maintenance is essential to keep the device always efficient, safe and reliable over time.

5.1 Preliminary warnings

⚠ This section is dedicated to the Technical Service Assistance. The features of the Technical Service Assistance are described in chapter "Recipients" p. 6.

⚠ This unit contains fluorinated greenhouse gases covered by the Kyoto Protocol. Maintenance and disposal operations must be carried out by qualified personnel only.

Before each cleaning and maintenance intervention:

- disconnect the device from the power mains by turning the system master switch to "OFF"
- wait for the components to cool down in order to avoid any burns

⊖ Carrying out any technical or cleaning work before disconnecting the unit from the power supply is forbidden.

⚠ Make sure that there is no voltage before operating.

⚠ After completing the maintenance work, must be restored the original condition.

5.1.1 Preliminary warnings for R32

⚠ The unit uses environmentally friendly R32 refrigerant gas, with a Global Warming Potential (GWP) = 675. Do not release R32 gas into the atmosphere.

⚠ R32 refrigerant gas is slightly flammable and odourless.

⚠ All precautions concerning the treatment of the refrigerant must be observed following the regulations in force.

⚠ Avoid proximity to sources of ignition in continuous operation (open flames, gas appliances, electric stoves, lighted cigarettes, etc.).

⊖ Smoking in the vicinity of the appliance is prohibited.

⊖ Using a mobile phone near the appliance is prohibited.

⚠ Perform the following checks:

- carry out safety checks to ensure that the risk of combustion is minimised
- avoid working in confined spaces
- delimit the area around the workspace
- ensure safe working conditions around the area by controlling flammable material

Leak detection

⊖ The use of combustion fluid detectors, e.g. a halide torch or other detection system using an open flame, is forbidden.

⚠ Follow the instructions below for leak detection:

- use electronic detectors to detect flammable refrigerants
- check that the detectors are properly calibrated before use
- calibration operations must be carried out in an area free from refrigerant
- make sure that the detector is not a potential source of combustion and that it is suitable for the refrigerant used
- all open flames must be removed if a leak is suspected
- in the event of a leak requiring brazing, it is mandatory to recover all the refrigerant from the system or isolate it (by means of shut-off valves) in a part of the system away from the leak

⚠ The use of silicone sealant may affect the effectiveness of some types of leak detectors.

5.2 Once-a-year operations

The once-a-year maintenance plan includes the following operations and checks and must be carried out by the Technical Service Centre or by qualified personnel.

5.2.1 Routine maintenance of the unit

Hydraulic circuit

Check:

- water circuit filling
- filter cleanliness
- pressure switch and flowmeter control
- absence of air in the circuit (venting)
- that the water flow rate is always constant at the evaporator
- the status of thermal insulation of the hydraulic piping

- the glycol percentage, if any

Electric circuit

Check:

- electrical supply voltage
- electric draw
- tightness of connections
- that there is no damage or excessive wear on the electrical cables
- the seals and sealing materials have not deteriorated to such an extent that they are no longer suitable for preventing the development of flammable atmospheres inside
- correct fixing of the cable clamps
- safety devices

Mechanical checks

Check:

- the tightness of the screws, the compressors and the electrical box, the external panelling of the unit
- the conditions of the structure

- ⚠ Poor fastenings cause abnormal noises and vibrations.
- ⚠ Treat any rusty parts with paints suitable to eliminate or reduce the rust.

Cleaning

- clean cosmetic covering elements

Refrigeration checks

Make sure that:

- the amount of charge complies with the size of the room in which the parts containing the refrigerant are installed (Minimum floor area reference table)
- ventilation equipment and vents functioning properly and not obstructed
- the marking on the equipment must remain visible and legible. Illegible markings and graphics must be corrected
- the refrigerant pipes and components are installed in a position in which they are unlikely to be exposed to corrosive substances unless the components are made of inherently corrosion-resistant materials or adequately protected against corrosion
- the thermodynamic values are within the nominal parameters

Under the provisions of Directive 517/2014/EU, plants containing more than 5 equivalent tonnes of CO₂ (7.41 kg of R32 gas or 2.39 kg of R410a gas) must be checked for leaks once a year, using either direct or indirect methods, by personnel certified under EU Regulation 2015/2067.

The company responsible for maintenance must keep a logbook in which the following information is recorded:

- the technician who performed the maintenance or repair,
- the dates and results of the checks,
- the quantity and type of fluorinated gas used,
- any quantities added or recovered during servicing, repair or final disposal.

- ⚠ If needed, a form is available at in the manual of the combined external unit.

- ⚠ Filling the refrigeration circuit with a refrigerant other than the one indicated is forbidden. Using a different refrigerant gas can cause serious damage to the unit.

5.3 Periodic operations

The routine maintenance plan includes the following cleaning operations.

5.3.1 External cleaning

Clean the external surfaces with a soft damp cloth.

- ⚠ Disconnect the unit from the power supply before each cleaning and maintenance intervention by setting the main power supply switch to off.
- ⚠ Do not use abrasive sponges or abrasive or corrosive detergents as you might damage the painted surfaces.

5.2.2 Cleaning the net filter

To extract:

- use an Allen key
- unscrew the end cap
- extract the filter

To clean:

- remove dust from the mesh filter
- wash the filter with water, without using detergents or solvents

5.2.3 Cleaning the air filter

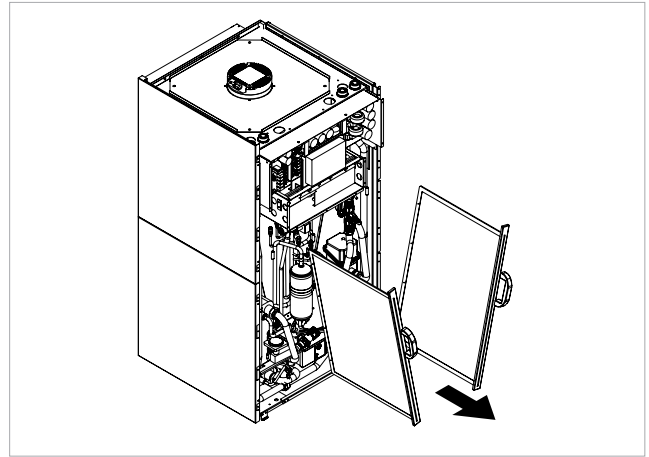

To extract:

- remove the cosmetic panels (if fitted)
- see chapter "Smontaggio elementi copertura" [p. 45](#)
- grasping the handle
- remove the filter from its housing

To clean:

- use a vacuum cleaner
- aspirate dust

If the quantity of dust is considerable:

- wash the filter under running water (max. 40 °C)
- allow to dry in the shade

- ⚠ Exposure to the sun or washing water temperatures above 40 °C can shrink the filters.

- ⊖ It is forbidden to use detergents or solvents to clean the filter.

TROUBLESHOOTING

6.1 Preliminary warnings

Should you encounter any of the anomalies below:

- the ventilation does not start even if the water circuit is filled with hot or cold water
- the device is losing water in heating mode
- the device is losing water in cooling mode
- the device generates excessive noise
- there is dew on the front panel

Follow the instructions below:

- disconnect the device from power supply immediately
- close the water taps
- contact an authorised Technical Assistance Centre or professionally qualified personnel

 The interventions must be carried out by a qualified installer or by a specialized support center.

 Do not intervene personally.

6.2 Functional aspects not to be interpreted as faults

- The following functional aspects may occur during the operation of the appliance, these behaviours of the appliance are correct and should not be interpreted as a fault.
- The compressor does not start again until 3 minutes after being shut off.
- During operation in heating mode of systems with heat pump, heat is produced a few minutes after the compressor starts.
- Periodic defrosting cycles occur during heating operation.
- When switching from domestic hot water production to cooling and vice versa, the external heat pump is kept off for one minute to avoid mixing hot and cold water.

6.3 Faults reported by the Control Panel



Faults are indicated on the display of the Control Panel.

 For reading, refer to the Control Panel Manual.

Manual reset of alarms

Repeating a fault several times will put the appliance in safety and the alarm must be reset manually.

To restore:

- press and hold  for a few seconds
- the padlock disappears from the symbol 
- then the symbol  disappears

6.4 Troubleshooting Table

Alarm	Description	Correlated variables	Correlated parameters	Activation conditions	Restoration conditions	Cause
ALRM 001	Temperature probe malfunction	PT1, PT4, PT5, PT6, MT1-6	-	Probe disconnected, faulty or abnormal value		
ALRM 002	Low-pressure switch tripped	MI2	-	Open pressure switch opening contact		<ul style="list-style-type: none"> Insufficient refrigerant charge Excessive amount of antifreeze Insufficient air flow to air cooler
ALRM 003	High-pressure switch tripped	MI1	-	Open pressure switch opening contact		<ul style="list-style-type: none"> Excessive refrigerant charge Presence of non-condensable gases (air) Insufficient air flow to air cooler Set point setting too high Air temperature outside operating limits
ALRM 004	Inverter driver high temperature	-	-	Driver temperature > 100 °C	Driver temperature < 90 °C	<ul style="list-style-type: none"> Heat sink obstruction
ALRM 006	Inverter driver error	-	-	Driver active alarm		<ul style="list-style-type: none"> Faulty driver card
ALRM 007	Compressor suction low temperature	MT1	PM24, PM25	MT1 < PM24	MT1 > PM24 + PM25	<ul style="list-style-type: none"> Insufficient refrigerant charge Excessive amount of antifreeze Insufficient air flow to air cooler
ALRM 008	Compressor discharge high temperature	MT2	PM23	MT2 > PM23	MT2 < PM23 - 10 °C	<ul style="list-style-type: none"> Incorrect refrigerant charge Presence of non-condensable gases (air)
ALRM 009	Communication error	-	-	Serial connection fault between control panel and Main board		<ul style="list-style-type: none"> Cable interrupted or disconnected
ALRM 010	Evaporator liquid refrigerant low temperature	MT4 (cooling), MT5 (heating)	PM102, PM1	t < PM102	t > PM102 + PM1	<p>Heating:</p> <ul style="list-style-type: none"> insufficient air flow to air cooler <p>Cooling:</p> <ul style="list-style-type: none"> insufficient water flow rate excessive amount of antifreeze
ALRM 012	Fan malfunction	-	-	No feedback from fan		<ul style="list-style-type: none"> Faulty fan motor
ALRM 017	Plant flowmeter tripped	PI1, PP1	-	PP1 active but PI1 open (with delay)	PP1 active and PI1 closed (with delay)	<p>Check that:</p> <ul style="list-style-type: none"> the check valves are open the 3-way valve for hot-cold diversion (if present) is in the correct position there are no air bubbles inside the circuit at least one of the consumers has an open circuit or is equipped with a 3-way valve the external sieve filter is not clogged the plant water pressure is correct the circulation pump is working properly (unlock it if necessary)
ALRM 022	High water temperature during domestic hot water production	The maximum value between PT5, PT6, PT4	PF28, PM1	t > PF28	t < PF28 - PM1	<ul style="list-style-type: none"> Set point setting too high Incorrect type of domestic hot water storage tank Domestic hot water temperature probe PT4 not positioned correctly
ALRM 023	High water temperature during heating operation	The maximum value between PT5, PT6, PT1 if enabled	PF27, PM1	t > PF27	t < PF27 - PM1	<ul style="list-style-type: none"> Set point setting too high Minimum water flow rate

Alarm	Description	Correlated variables	Correlated parameters	Activation conditions	Restoration conditions	Cause
ALRM 025	Plant exchanger antifreeze cooling operation	The minimum value between PT5 and PT6	PF23	$t < PF23$	$t > PF23 + PM1$	Check that: <ul style="list-style-type: none"> nothing is preventing the good water circulation in the plant (air, partially closed valves, clogged sieve filter, etc.) the thermal gradient between the delivery and return is between 4-7 °C. Query the t1 and t3 parameters Set a lower circulation pump speed if the thermal gradient is less than 4 °C. If the thermal gradient is greater than 7 °C, check that all the valves on the plant are open and if necessary add an external pump to increase the water flow rate or insert a hydraulic separator.
ALRM 027	Domestic hot water storage antifreeze during cooling operation	PT4	PF23	$t < PF23$	$t > PF23 + PM1$	
ALRM 028	Plant exchanger and tank antifreeze during cooling operation	The minimum value between PT5, PT6, PT1 if enabled	PF23	$t < PF23$	$t > PF23 + PM1$	

- Note:**
- In general, alarm resetting is automatic when the activation condition is established again.
- The activation or reset conditions must remain for a preset time (e.g. 30 s) before the alarm is activated or deactivated on the display. The duration of the preset time depends on the alarm type.
- If the alarm trips multiple times in a given time (e.g. 3 times in 1 hour), it must be reset manually by the Technical Service Centre.

TECHNICAL INFORMATION

7.1 Technical data

			3in1 Mono	
Models		m.u.	5	7
Heating performances (A 7 °C BS; W 35 °C)				
Maximum heat output	(1)	kW	7,50	9,04
Nominal heat power	(1)	kW	4,49	5,52
Total absorbed power	(1)	kW	1,02	1,28
COP	(1)		4,40	4,31
SCOP	(1)		4,21	4,13
Energy efficiency class			A++	
Heating performances (A-7 °C BS; W 35 °C)				
Maximum heat output	(2)	kW	5,16	6,24
Total absorbed power	(2)	kW	1,76	2,40
COP	(2)		2,93	2,70
Cooling performances (A35 °C; W 18 °C)				
Maximum cooling capacity	(3)	kW	8,11	10,28
Nominal cooling capacity	(3)	kW	5,53	6,56
Total absorbed power	(3)	kW	1,38	1,67
EER	(3)		4,01	3,93
Cooling performances (A35 °C; W 7°C)				
Maximum cooling capacity	(4)	kW	6,25	7,83
Nominal cooling capacity	(4)	kW	4,04	4,88
Total absorbed power	(4)	kW	1,38	1,78
EER			2,93	2,74
Hydraulic data				
Nominal flow rate		L/min	15,0	21,0
Available pressure primary circuit		kPa	65,0	55,0
Diameter of hydraulic fittings		"GAS	1	
expansion vessel capacity		L	4	4
DHW tank capacity		L	200	200
Minimum system water content		L	20	25
Aeraulic data				
Type of fan			Modulating	
Maximum air flow		m ³ /h	1850	2200
Minimum flow rate		m ³ /h	750	900
1. Water temperature in/out 30/35 °C; outdoor air temperature 7 °C; U.R. 85% 2. Water temperature in/out 30/35 °C; outdoor air temperature -7 °C 3. Water in/out temperature 23/18 °C; outside air temperature 35 °C (radiant application) 4. Water temperature in/out 12/7 °C; Outdoor air temperature 35 °C (fancoil application) 5. To be set during start-up 6. Indoor sound pressure measured at a distance of 1 m according to ISO 7779				

			3in1 Mono	
Models		m.u.	5	7
Static pressure rating set		Pa	80	80
Static pressure available	(5)	Pa	200	200
Wall hole diameter		mm	200	200
Expulsion/immission		(bxh) mm	470x350	
Refrigerant gas data				
Compressor			Twin Rotary DC Inverter	
Type of refrigerant			R32	
Quantity of refrigerant		kg	1,55	1,55
Sound data				
Nominal sound pressure	(6)	dB(A)	47	49
Electrical data				
Power Supply		V/ph/Hz	230/1/50	230/1/50
Maximum absorbed power		kW	3,80	4,10
Maximum absorbed current		A	14,00	19,00
Maximum absorbed power booster		kW	2,00	2,00
Maximum current consumption booster		A	8,60	8,60
Indoor unit protection degree			IPX2	
1. Water temperature in/out 30/35 °C; outdoor air temperature 7 °C; U.R. 85% 2. Water temperature in/out 30/35 °C; outdoor air temperature -7 °C 3. Water in/out temperature 23/18 °C; outside air temperature 35 °C (radiant application) 4. Water temperature in/out 12/7 °C; Outdoor air temperature 35 °C (fancoil application) 5. To be set during start-up 6. Indoor sound pressure measured at a distance of 1 m according to ISO 7779				

7.2 Operating limits

Domestic hot water

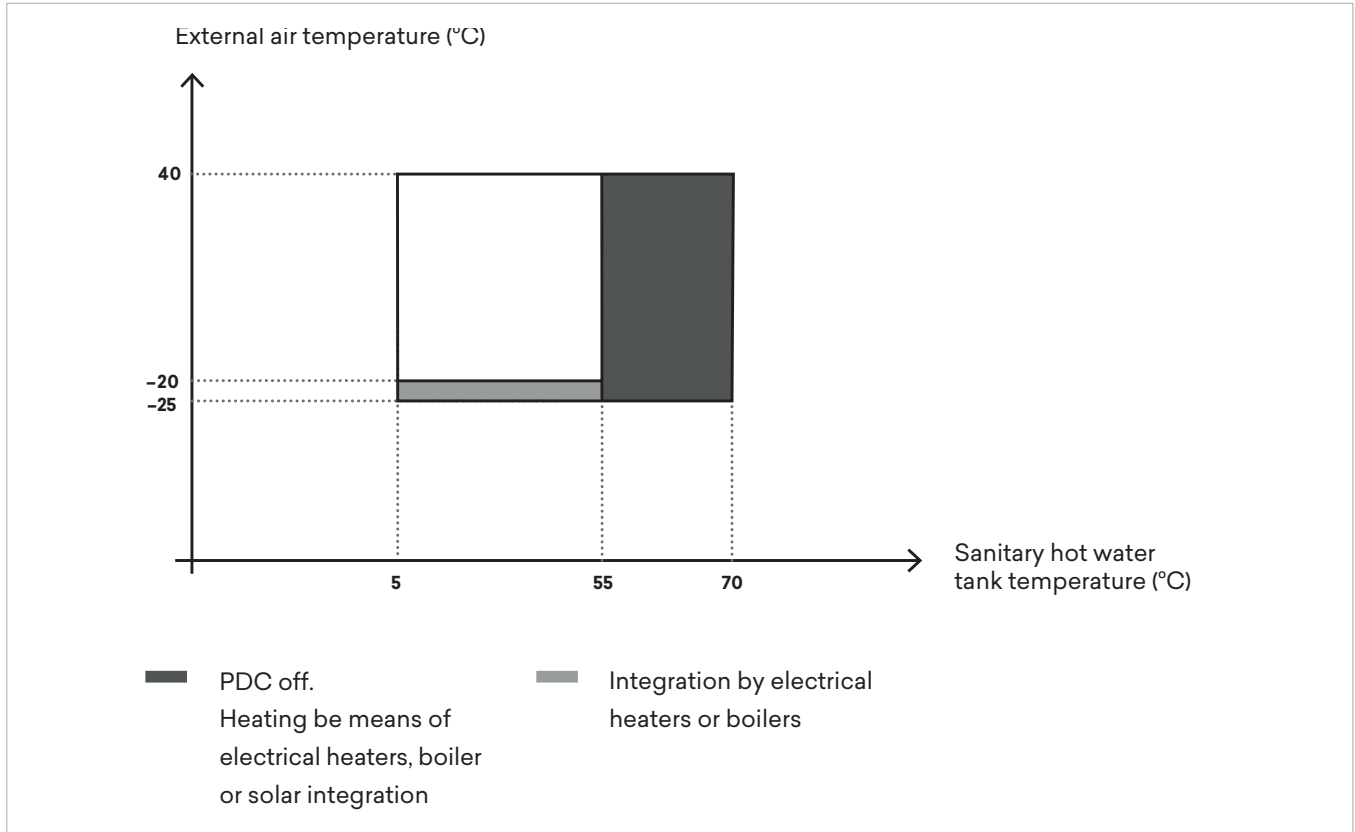

⚠ The areas represented by the graph marked by back-up heater are simplified. They could be more advantageous (greater contribution of the heat pump) in relation to the operating conditions and internal operating parameters.

⚠ the unit may reduce the outlet water temperature of the condenser at outdoor air temperatures below -15 °C.

Cooling

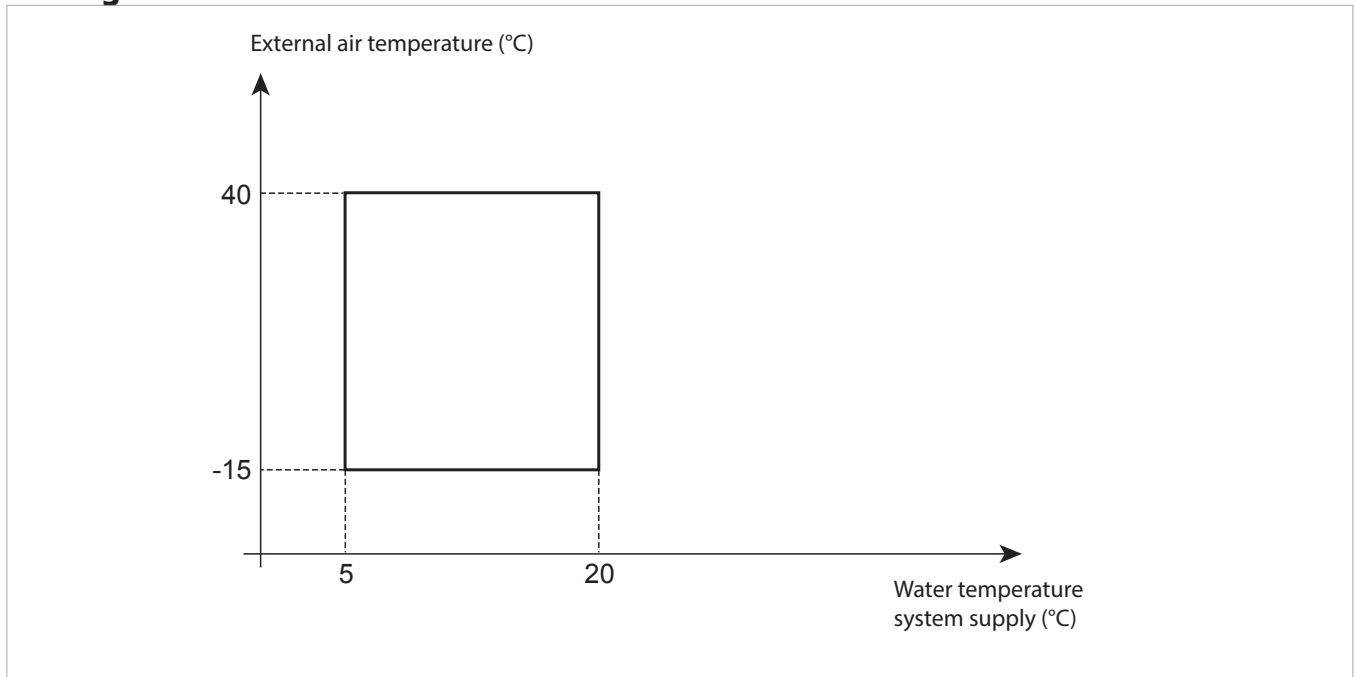

*The area represented by the graph is simplified. It may be more advantageous depending of outdoor and working conditions.

Heating

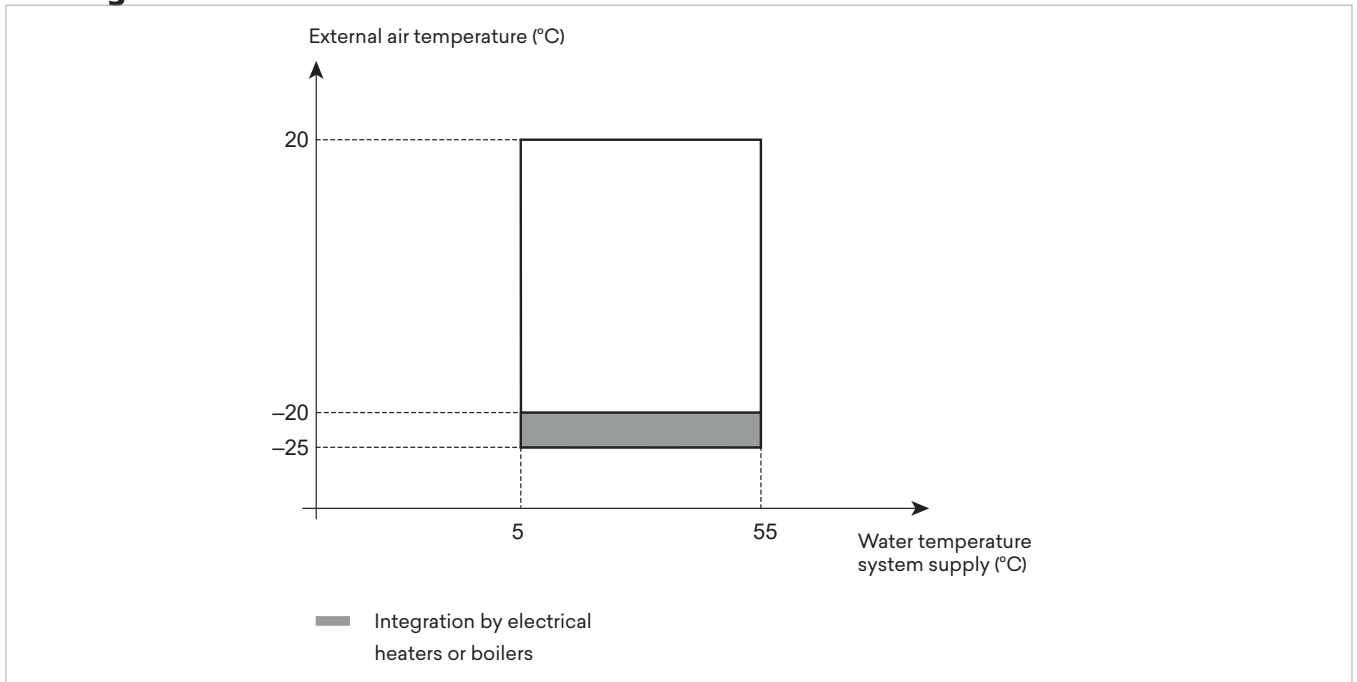

⚠ The areas represented by the graph marked by back-up heater are simplified. They could be more advantageous (greater contribution of the heat pump) in relation to the operating conditions and internal operating parameters.

⚠ the unit may reduce the outlet water temperature of the condenser at outdoor air temperatures below -15 °C.

7.3 Dimensions

7.3.1 SV - Version with vertical coupling

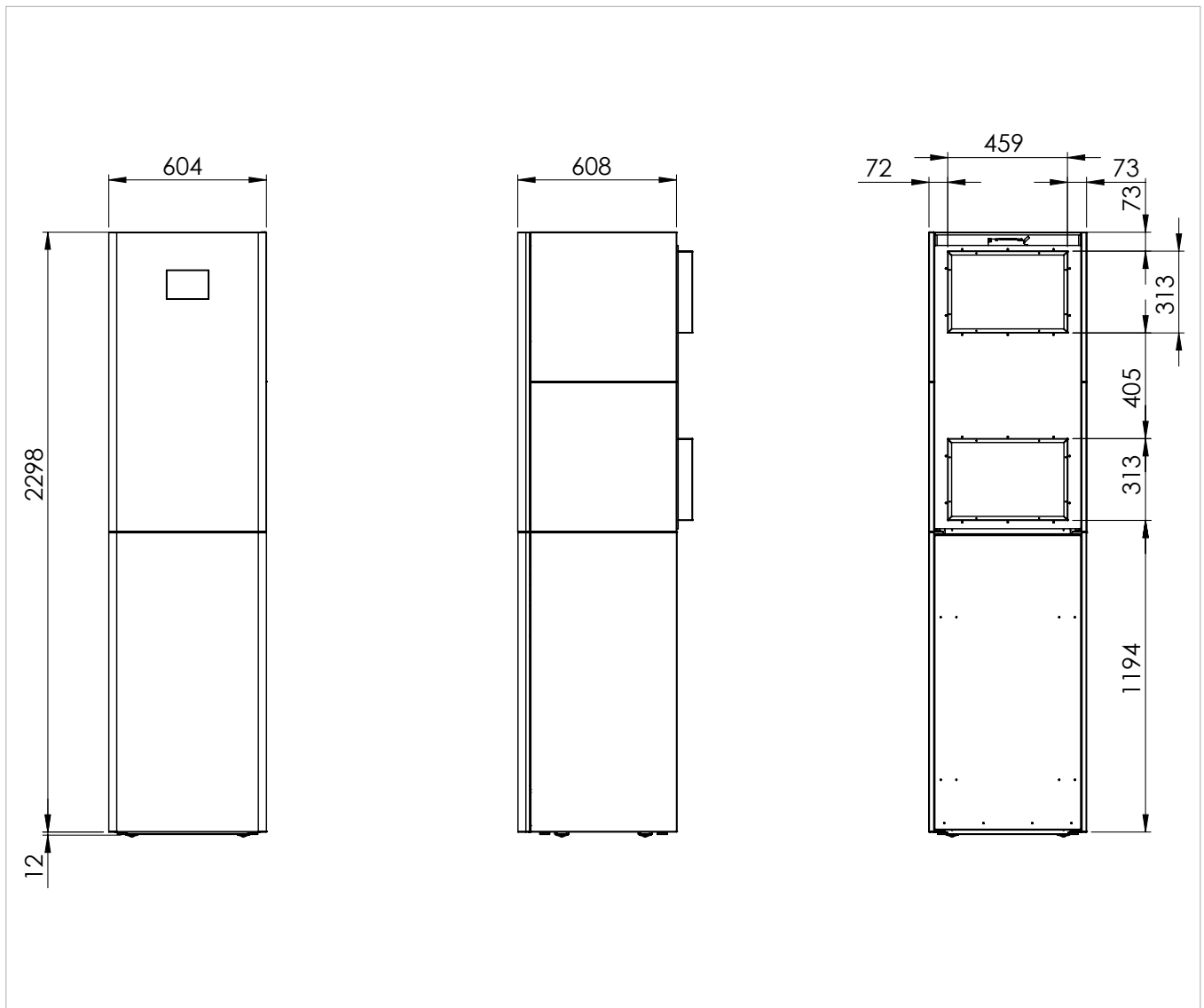

Weight

Models	m.u.	5	7
Net weighth	kg	240,0	240,0

7.3.2 SH - Version with horizontal coupling

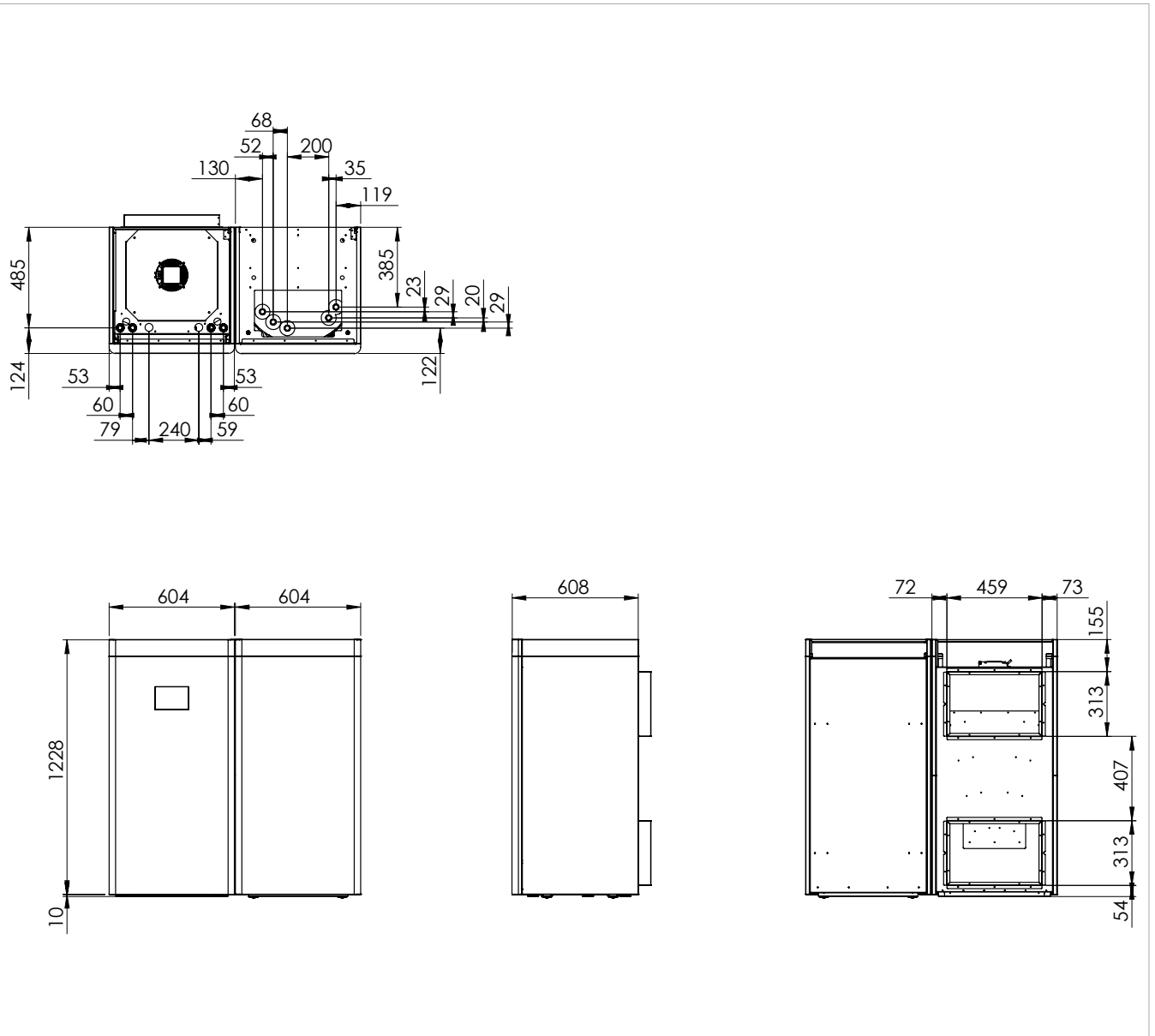

Weight

Models	m.u.	5	7	
Net weighth	(1)	kg	125,0/115,0	125,0/115,0

1. Weights refer to separate heat pump/ACS module

7.3.3 S - Single version

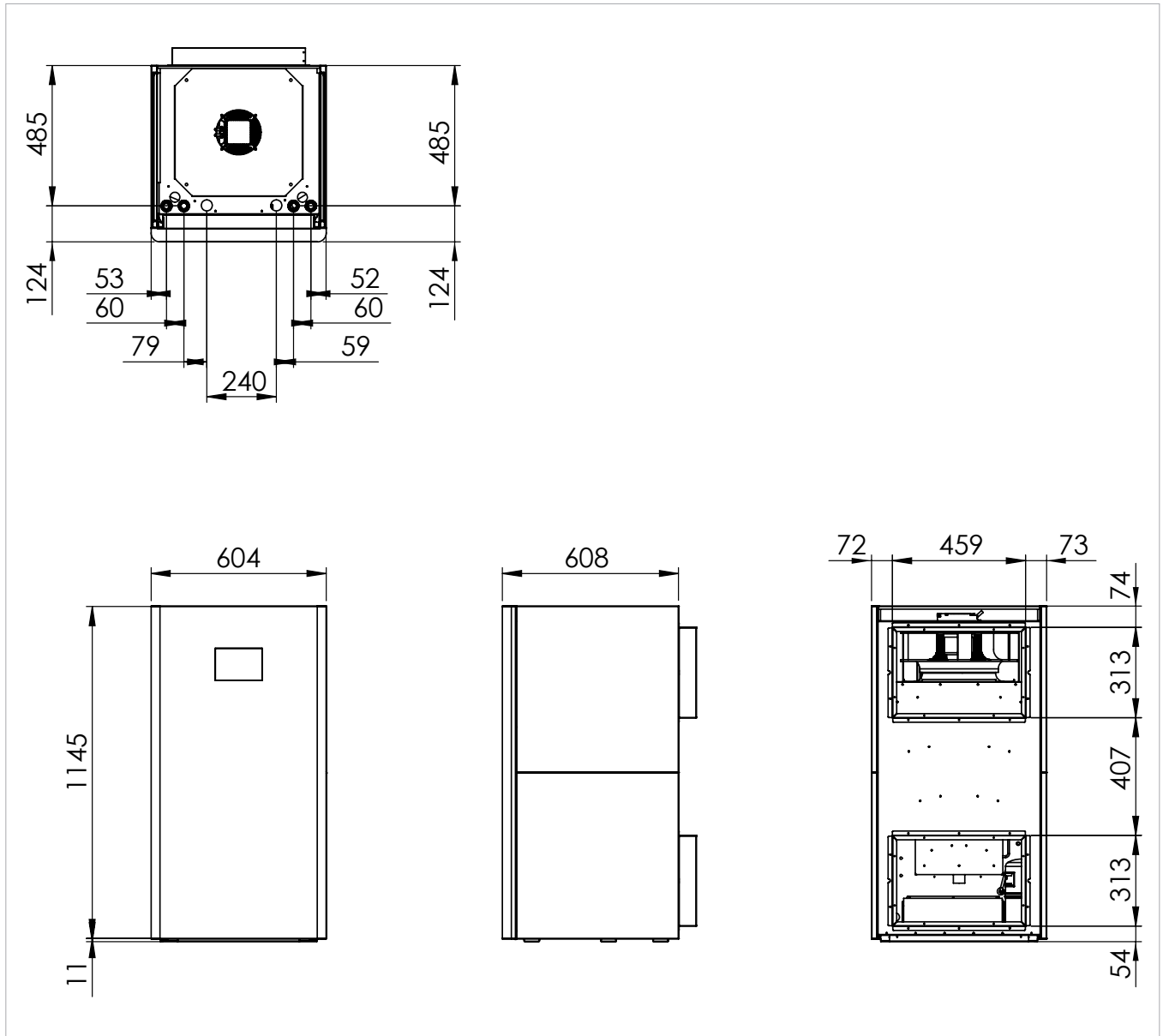

Weight

Models	m.u.	5	7
Net weighth	kg	125,0	125,0

7.4 Refrigerator diagram

- A** Heat pump module
- B** Hydraulic circuit
- 1.** Water inlet probe
- 2.** Water outlet probe
- 3.** Plate exchanger
- 4.** Refrigerant probe internal heat exchanger
- 5.** Liquid receiver
- 6.** Thermostatic valve
- 7.** External coil
- 8.** Fan
- 9.** Coil centre probe

- 10.** External air probe
- 11.** Condensate drip tray heating element
- 12.** Refrigerant probe external heat exchanger
- 13.** Four-way valve
- 14.** Service valve
- 15.** High-pressure switch
- 16.** Low-pressure switch
- 17.** Compressor discharge probe
- 18.** Intake probe
- 19.** Compressor

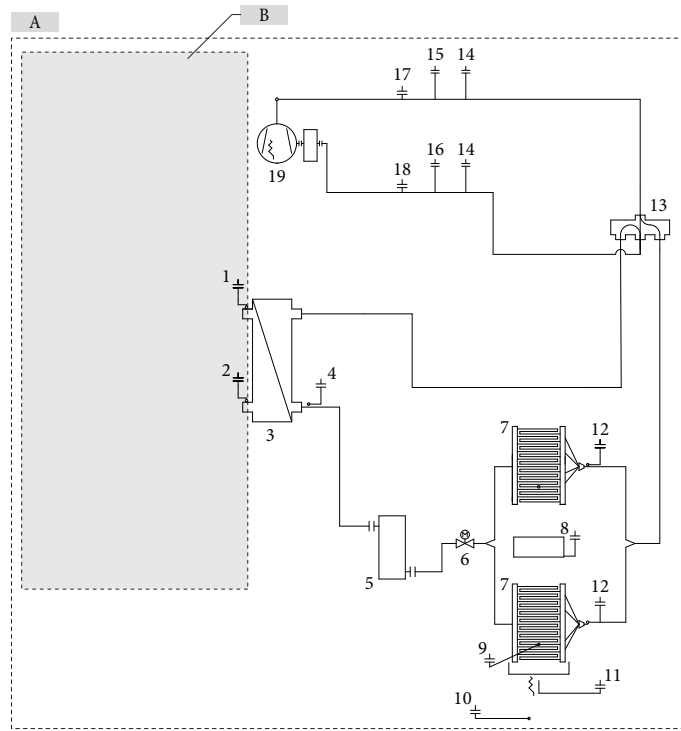

7.5 PP1 circulation pump graphs

7.5.1 Model 5 - 7

H Available pressure

Q Water flow rate

Curves refer to fixed maximum speed

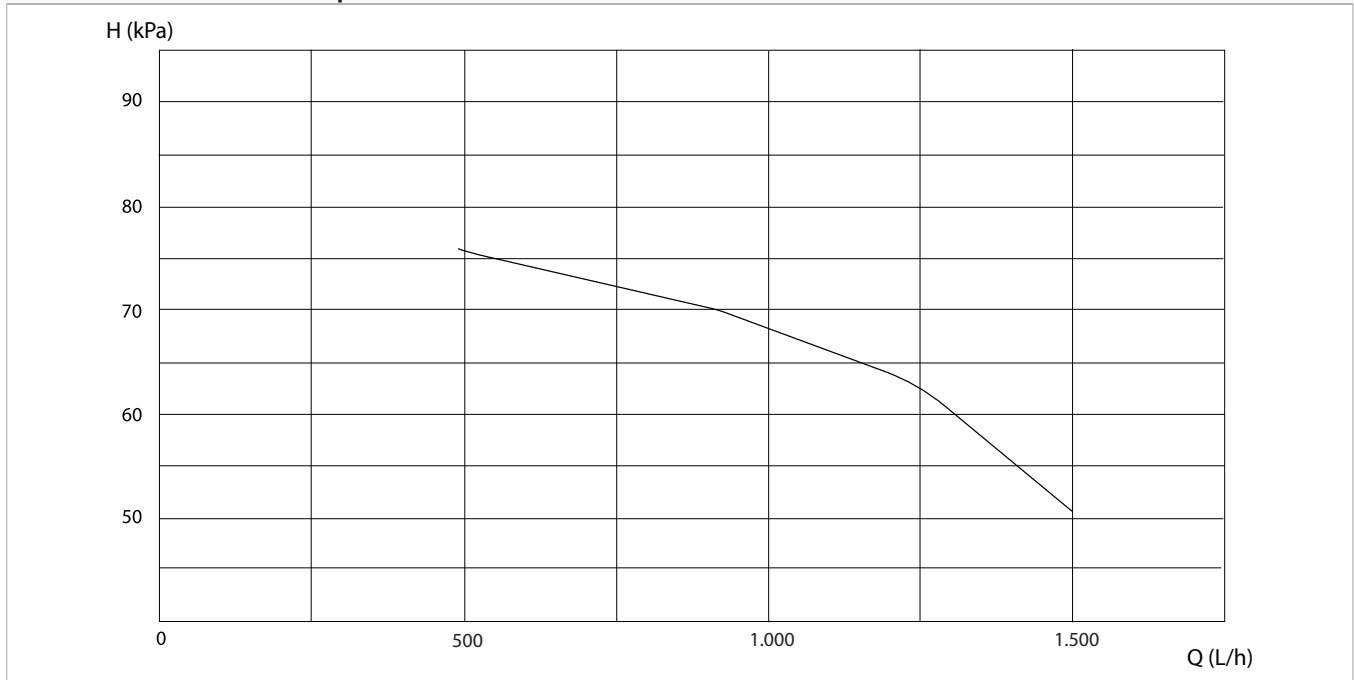



innova

INNOVA S.r.l.
Via I Maggio 8 - 38089 Storo (TN) - ITALY
tel. +39.0465.670104 - fax +39.0465.674965
info@innovaenergie.com