

Installation Manual
(Translation of original
instructions)

EN



N420494B - Rev. 04 - 03/2024

Filomuro Slim Fit XL

SW XL 800

First of all, we would like to thank you for having chosen a device of our production.

We are sure you will be happy with it because it represents the state of the art in the technology of home air conditioning.

By following the suggestions contained in this manual, the product you have purchased will operate without problems giving you optimum room temperatures with minimum energy costs.

INNOVA S.r.l.

Conformity

This unit complies with the European directives:

- Low voltage 2014/35 / EU
- EMC 2014/30/EU
- RoHS 2011/65/UE

Markings



TABLE OF CONTENTS

1	Coding	<u><i>p. 7</i></u>
1.1	Product related coding	<u><i>p. 7</i></u>
2	General information	<u><i>p. 8</i></u>
2.1	About the manual	<u><i>p. 8</i></u>
2.1.1	Editorial pictograms	<u><i>p. 8</i></u>
2.1.2	Pictograms on the product	<u><i>p. 8</i></u>
2.1.3	Recipients	<u><i>p. 8</i></u>
2.1.4	Manual organisation	<u><i>p. 8</i></u>
2.2	General warnings	<u><i>p. 9</i></u>
2.3	Basic rules of security	<u><i>p. 9</i></u>
2.4	Disposal	<u><i>p. 10</i></u>
3	Product presentation	<u><i>p. 11</i></u>
3.1	Identification	<u><i>p. 11</i></u>
3.2	Destination of use	<u><i>p. 11</i></u>
3.3	Description of the appliance	<u><i>p. 11</i></u>
3.4	Components	<u><i>p. 12</i></u>
3.5	Compatible accessories	<u><i>p. 12</i></u>
4	Installation	<u><i>p. 15</i></u>
4.1	Preliminary warnings	<u><i>p. 15</i></u>
4.2	Reception	<u><i>p. 15</i></u>
4.2.1	Preliminary warnings	<u><i>p. 15</i></u>
4.2.2	Package description	<u><i>p. 15</i></u>
4.3	Dimensions and weights with packaging	<u><i>p. 15</i></u>
4.4	Handling with packaging	<u><i>p. 16</i></u>
4.4.1	Preliminary warnings	<u><i>p. 16</i></u>
4.4.2	Movement methods	<u><i>p. 16</i></u>
4.5	Storage	<u><i>p. 16</i></u>
4.5.1	Preliminary warnings	<u><i>p. 16</i></u>
4.6	Unpacking	<u><i>p. 16</i></u>
4.6.1	Preliminary warnings	<u><i>p. 16</i></u>
4.6.2	Remove the package	<u><i>p. 17</i></u>
4.7	Handling without packaging	<u><i>p. 17</i></u>
4.7.1	Preliminary warnings	<u><i>p. 17</i></u>
4.7.2	Movement methods	<u><i>p. 17</i></u>
4.8	Installation site	<u><i>p. 17</i></u>
4.8.1	Preliminary warnings	<u><i>p. 17</i></u>
4.9	Installation mode	<u><i>p. 18</i></u>
4.10	Installation minimum distances	<u><i>p. 18</i></u>
4.11	Positioning	<u><i>p. 19</i></u>

4.11.1	Preliminary warnings	<u>p. 19</u>
4.11.2	Device preparation	<u>p. 19</u>
4.11.3	Installation arrangement	<u>p. 20</u>
4.11.4	Positioning	<u>p. 20</u>
4.12	Hydraulic connections	<u>p. 21</u>
4.12.1	Preliminary warnings	<u>p. 21</u>
4.12.2	Position and dimensions.	<u>p. 21</u>
4.12.3	Connection to the system	<u>p. 22</u>
4.12.4	Shut-off valves	<u>p. 22</u>
4.13	Condensation drain preparation	<u>p. 22</u>
4.13.1	Preliminary warnings	<u>p. 22</u>
4.13.2	Positioning	<u>p. 22</u>
4.13.3	Check.	<u>p. 23</u>
4.14	Filling the system	<u>p. 23</u>
4.14.1	Mounting the thermostatic head	<u>p. 23</u>
4.15	Electric connections	<u>p. 24</u>
4.15.1	Preliminary warnings	<u>p. 24</u>
4.15.2	Power line dimensioning	<u>p. 24</u>
4.15.3	Access to the terminal block	<u>p. 25</u>
4.15.4	Electrical connection and settings.	<u>p. 25</u>
5	Touchpad and remote control Code ECA789	<u>p. 26</u>
5.1	Interface	<u>p. 26</u>
5.2	Printed circuit board ECA789	<u>p. 27</u>
5.3	Connections	<u>p. 28</u>
	Presence contact CP	<u>p. 28</u>
5.4	Functions.	<u>p. 28</u>
5.4.1	Basic menu	<u>p. 28</u>
5.4.2	Advanced Menu	<u>p. 28</u>
5.4.3	Error signals	<u>p. 29</u>
5.4.4	Visualization of alarms on display	<u>p. 29</u>
6	M7 series control Code EEB749	<u>p. 30</u>
6.1	Interface	<u>p. 30</u>
6.2	Installation.	<u>p. 30</u>
6.2.1	Description	<u>p. 30</u>
6.2.2	Mounting	<u>p. 30</u>
6.3	Single connection diagram	<u>p. 32</u>
6.4	Multiple connection diagram	<u>p. 33</u>
6.5	Connections	<u>p. 34</u>
6.5.1	Preliminary warnings	<u>p. 34</u>
6.5.2	Control Panel	<u>p. 34</u>
6.5.3	Presence contact CP	<u>p. 34</u>
6.5.4	RS485 Serial Connection.	<u>p. 35</u>
6.6	Functions.	<u>p. 35</u>
6.6.1	Basic menu	<u>p. 35</u>
6.6.2	Advanced Menu	<u>p. 36</u>
6.6.3	Pairing of control and unit	<u>p. 36</u>
6.6.4	Error signals	<u>p. 37</u>
6.6.5	Alarm display on wall control panel	<u>p. 38</u>

7	M7 series control Code EGB749	<u>p. 39</u>
7.1	Interface	<u>p. 39</u>
7.2	Installation	<u>p. 39</u>
7.2.1	Description	<u>p. 39</u>
7.2.2	Mounting	<u>p. 39</u>
7.3	Single connection diagram	<u>p. 41</u>
7.4	Multiple connection diagram	<u>p. 42</u>
7.5	Connections	<u>p. 43</u>
7.5.1	Preliminary warnings	<u>p. 43</u>
7.5.2	Control Panel	<u>p. 43</u>
7.5.3	Presence contact CP	<u>p. 43</u>
7.5.4	Bluetooth connection	<u>p. 44</u>
7.6	Functions	<u>p. 44</u>
7.6.1	Basic menu	<u>p. 44</u>
7.6.2	Advanced Menu	<u>p. 44</u>
7.6.3	Pairing of control and unit	<u>p. 45</u>
7.6.4	Error signals	<u>p. 47</u>
7.6.5	Alarm display on wall control panel	<u>p. 47</u>
8	Remote control EEA649 - EEB649 / EFA649 - EFB649	<u>p. 48</u>
8.1	Interface	<u>p. 48</u>
8.2	Installation	<u>p. 48</u>
8.2.1	Description	<u>p. 48</u>
8.2.2	Mounting	<u>p. 48</u>
8.3	Single connection diagram	<u>p. 50</u>
8.4	Multiple connection diagram	<u>p. 51</u>
8.5	Connections	<u>p. 51</u>
8.5.1	Preliminary warnings	<u>p. 51</u>
8.5.2	Control Panel	<u>p. 52</u>
8.5.3	Presence contact CP	<u>p. 52</u>
8.5.4	RS485 Serial Connection.	<u>p. 52</u>
8.5.5	Set-up of auxiliary dip-switch functions	<u>p. 52</u>
8.6	Functions	<u>p. 53</u>
8.6.1	Advanced Menu	<u>p. 53</u>
8.6.2	Long period shut-down	<u>p. 54</u>
8.6.3	LED signals	<u>p. 54</u>
8.6.4	Alarm display on wall control panel	<u>p. 54</u>
9	Fixed speed remote controls Code B3V151	<u>p. 55</u>
9.1	Interface	<u>p. 55</u>
9.2	Description	<u>p. 55</u>
9.3	Connection diagram	<u>p. 56</u>
9.4	Connection diagram with seasonal switching	<u>p. 57</u>
9.5	Generic thermostat connection diagram	<u>p. 58</u>
9.6	Connections	<u>p. 59</u>
9.6.1	Connection with 3 speed thermostats	<u>p. 59</u>
9.6.2	Water probe management.	<u>p. 59</u>
9.7	Error signals	<u>p. 59</u>

10 0-10 V connection	<u>p. 60</u>
10.1 Connection diagram	<u>p. 60</u>
10.2 Connections	<u>p. 61</u>
10.3 Error signals	<u>p. 61</u>
11 Maintenance	<u>p. 62</u>
11.1 Preliminary warnings.	<u>p. 62</u>
11.2 Routine maintenance.	<u>p. 62</u>
11.3 External cleaning	<u>p. 62</u>
11.4 Air intake filter cleaning	<u>p. 63</u>
11.4.1 Inserting the filter	<u>p. 63</u>
11.5 Suggestions for energy saving	<u>p. 63</u>
12 Troubleshooting	<u>p. 64</u>
12.1 Preliminary warnings.	<u>p. 64</u>
12.2 Troubleshooting table	<u>p. 64</u>
13 Configuration accessories	<u>p. 65</u>
13.1 Shut-off valves.	<u>p. 65</u>
13.1.1 Connection with 2-way manual valve (I20205)	<u>p. 65</u>
13.1.2 Connection with 2-way valve and thermoelectric actuator (V20687)	<u>p. 66</u>
13.1.3 Connection with 3-way diverting valve unit with thermoelectric actuator (V30718)	<u>p. 66</u>
14 Technical information	<u>p. 67</u>
14.1 Technical data	<u>p. 67</u>
14.2 Dimensions	<u>p. 68</u>
14.3 Installation template	<u>p. 68</u>

CODING

Product related coding

This instruction manual refers to the following product codes.

⚠ Check the correspondence with the technical rating plate on the product. See chapter "Identification" *p. 11*.

Filomuro Slim Fit XL			
FAWB08DC1II0B00	SW XL 800	Right-handed fittings	For connection with M7 series Bluetooth remote controls (modulating speed)
FAWB08DC1II0P00	SW XL 800	Right-handed fittings	For connection with Smart Touch series remote controls (modulating speed).
FAWB08DC1II0Q00	SW XL 800	Right-handed fittings	With touchpad and remote control
FAWB08DC1II0R00	SW XL 800	Right-handed fittings	For connection with M7 series remote controls (modulating speed)
FAWB08DC1II0T00	SW XL 800	Right-handed fittings	For connection with remote control (fixed speed)
FAWB08DC1II0V00	SW XL 800	Right-handed fittings	For 0-10 V connection (modulating speed)

GENERAL INFORMATION

2.1 About the manual

This manual was written to provide all the explanations for the correct management of the appliance.

- ⚠ This instruction manual forms an integral part of the device and therefore must be carefully preserved and must ALWAYS travel with it, even if you transfer the device to another owner or relocate it to other premises. If the manual gets damaged or lost, download a copy from the website.
- ⚠ Read this manual carefully before proceeding with any operation and follow the instructions in the individual chapters.
- ⚠ The manufacturer is not responsible for damages to persons or property caused by failure to follow the instructions in this manual.
- ⚠ This document is restricted in use to the terms of the law and may not be copied or transferred to third parties without the express authorization of the manufacturer.

2.1.1 Editorial pictograms

The pictograms in the next chapter provide the necessary information for correct, safe use of the machine in a rapid, unmistakable way.

Related to security

- ⚠ **High risk warning (bold text)**
 - The operation described above presents a risk of serious physical injury, fatality, major damage to the appliance and/or to the environment if not carried out in compliance with safety regulations.
- ⚠ Low risk warning (plain text)
 - The operation described above presents a risk of minor physical injury or minor damage to the appliance and/or to the environment if not carried out in compliance with safety regulations.
- ⊘ Prohibition (plain text)
 - Refers to prohibited actions.
- i **Important information (bold text)**
 - This indicates important information that must be taken into account during the operations.

In the texts

- procedures
- lists

In the control panels

- actions required
- Expected responses following an action.*

In the figures

- 1 The numbers indicate the individual components.
- A The capital letters indicate component assemblies.
- ① The white numbers in black marks indicate a series of actions to be carried out in sequence.
- Ⓐ The black letter in white identifies an image when there are several images in the same figure.

2.1.2 Pictograms on the product

Symbols are used in some parts of the appliance:

Related to security

- ⚠ **Caution: electrical danger**
 - The concerned personnel is informed to the presence of electricity and the risk of suffering an electric shock.

2.1.3 Recipients

User

Non-expert person capable of operating the product in safe conditions for people, for the product itself and the environment, interpreting an elementary diagnostic of faults and abnormal operating conditions, carrying out simple adjustment, checking and maintenance operations.

Installer

Expert person qualified to position and connect (hydraulically, electrically, etc.) the unit to the plant; this person is responsible for handling and correct installation according to the instructions provided in this manual and the national standards currently in force.

Technical Service Centre

Expert and qualified person authorised directly by the manufacturer to carry out all routine and supplementary maintenance operations, as well as every adjustment, check, repair and replacement of parts necessary during the life of the unit itself.

2.1.4 Manual organisation

The manual is divided into sections each dedicated to one or more target groups.

General information

It addresses all recipients. It contains general information and important warnings that should be known before installing and using the appliance.

Product presentation

It addresses all recipients. It contains the information to identify the product, its components, compatible accessories and destination of use.

Installation

It is addressed exclusively to the installer.

It contains specific warnings and all the information necessary for positioning, mounting and connecting the appliance.

Commissioning, maintenance and troubleshooting

They are addressed exclusively to the Technical Assistance Centre.

It contains specific warnings useful information for the most common commissioning and routine maintenance.

Configuration accessories

It is addressed to the installer and the Technical Assistance Centre.

It contains specific warnings and all detailed information on configuration accessories.

Technical information

It addresses all recipients.

It contains detailed technical information about the appliance.

2.2 General warnings

- ⚠ Specific warnings are given in each chapter of the document and must be read before starting operations.
- ⚠ All personnel involved must be aware of the operations and dangers that may arise when beginning all unit installation operations.
- ⚠ Installation performed outside the warnings provided in this manual and use of the appliance outside the prescribed temperature limits will invalidate the warranty.
- ⚠ The installation and maintenance of climate control equipment could be dangerous because there is live electrical components inside the appliances. The installation, initial start-up and subsequent maintenance phases must be carried out exclusively by authorised and qualified personnel (see first start-up request form enclosed with the appliance).
- ⚠ Any contractual or extra-contractual liability for damage caused to persons, animals or property, due to installation, adjustment and maintenance errors or improper use is excluded. All uses not expressly indicated in this manual are not permitted.
- ⚠ Only qualified installer companies are authorised to install the device. After having completed installation, the installer will issue a declaration of conformity to the plant manager, as required by the applicable standards and the guidelines provided by contractor's instruction manual supplied with the device.
- ⚠ First start-up and repair or maintenance operations must be carried out by the Technical Assistance Centre or by qualified personnel following the provisions of this manual.
- ⚠ Do not modify or tamper with the appliance as this can lead to dangerous situations.
- ⚠ Use suitable accident-prevention clothing and equipment during installation and/or maintenance operations. The manufacturer is not liable for the non-observance of the current safety and accident prevention regulations.
- ⚠ In the event of liquid or oil leaks, set the master switch of the plant to "off" and close the water taps. Call the authorised Technical Assistance Centre or professionally qualified personnel as soon as possible and do not work on the appliance yourself.
- ⚠ In case of replacement of parts, use only original parts.
- ⚠ The manufacturer reserves the right to make changes to its models at any time to improve its product, without prejudice to the essential characteristics described in this manual. The manufacturer is not obliged to add such modifications to machines previously manufactured, already delivered or under construction.
- ⚠ The unit can be used by children over the age of 8, and by people with reduced physical, sensory or mental capabilities, or with no experience or necessary knowledge, as long as they are monitored or after they have received instructions on the safe use of the unit and have understood the dangers involved. Children must not play with the appliance. The cleaning and maintenance that must be performed by the user should not be carried out by children without supervision.

2.3 Basic rules of security

Please keep in mind that the use of products powered by electricity and water call for operators to comply with certain essential safety rules:

- ⊖ The use of the appliance to children and unassisted disabled persons is prohibited.
- ⊖ It is forbidden to touch the device with wet or damp body parts.
- ⊖ It is forbidden to carry out any operation before disconnecting the appliance from the power supply by setting the plant master switch to "off".
- ⊖ It is forbidden to modify the safety or adjustment devices or adjust without authorization and indications of the manufacturer.
- ⊖ It is forbidden to pull, unplug or twist the device's electric cables, even if it is disconnected from the mains.
- ⊖ It is forbidden to introduce objects and substances through the air inlet and outlet grilles.
- ⊖ It is forbidden to open the access doors of the device's internal parts without first having set main switch of the system to "off".
- ⊖ It is forbidden to dispose of, or leave in the reach of children, the packaging materials which could become a source of danger.

2.4 Disposal



The symbol on the product or its packaging indicates that the product must not be treated as normal household waste, but must be taken to the appropriate collection point for the recycling of electrical and electronic equipment.

Proper disposal of this product avoids harm to humans and the environment and promotes the reuse of valuable raw materials.

For more detailed information about the recycling of this product, contact your local city office, your household waste disposal service or the shop where you purchased the product.

Illegal disposal of the product by the user involves the application of the administrative sanctions provided for by the regulations in force.

This provision is only valid in the EU Member States.

⚠ Avoid disassembling the unit yourself.

⚠ **Contact an authorised Technical Assistance Centre to disassemble the appliance.**

PRODUCT PRESENTATION

3.1 Identification

The appliance can be identified by the rating plate:

Technical rating plate

⚠ Tampering with, removal of, or lack of identification plates will not allow for the safe identification of the product by its serial number and therefore invalidates the warranty.

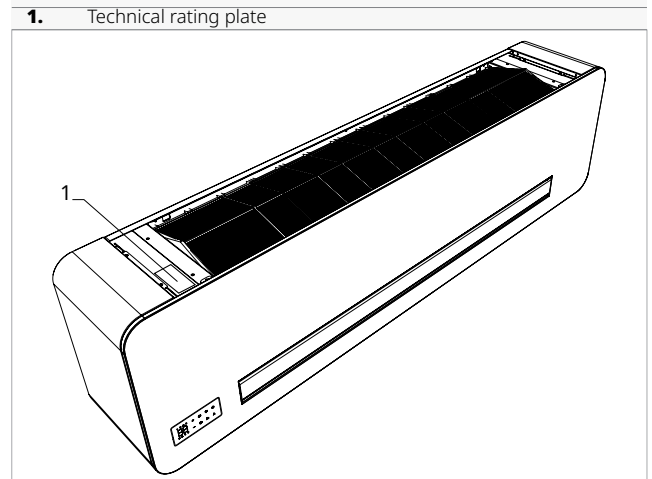

3.2 Destination of use

These appliances have been designed for conditioning and/or heating rooms and they must be destined solely for

this purpose, in accordance with their performance characteristics.

3.3 Description of the appliance

Filomuro Slim Fit XL fancoils range are designed for wall mounting.

The units are produced only in size 800, suitable for installation on two-pipe systems.

Filomuro Slim Fit XL fancoils range are available into six configurations based on control mode:

- **OQ00** - with touchpad and remote control
- **OR00** - for connection with M7 series remote controls (modulating speed)
- **OB00** - for connection with M7 series Bluetooth remote controls (modulating speed)
- **OP00** - for connection with Smart Touch series remote controls (modulating speed)
- **OT00** - for connection with remote controls (fixed speeds)
- **OV00** - for connection 0-10 V (modulating speed)





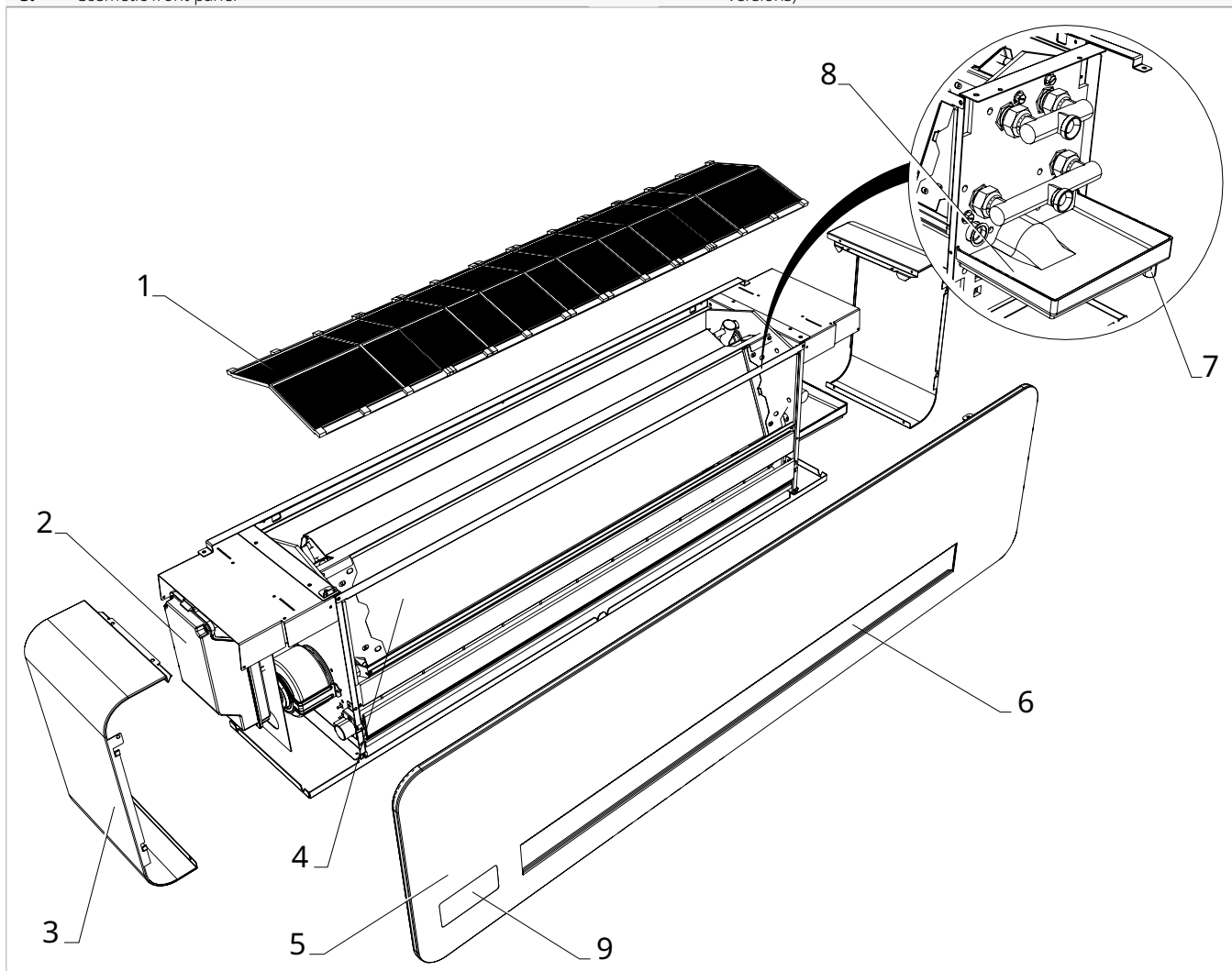





3.4 Components

- | | |
|---|---|
| <ul style="list-style-type: none"> 1. Air intake filter 2. Electrical box 3. Aesthetic sides 4. Heat exchanger 5. Cosmetic front panel | <ul style="list-style-type: none"> 6. Air outlet deflector 7. \varnothing 14 mm condensate drain 8. Condensation drain tray 9. On-unit control panel predisposition (only available for some versions) |
|---|---|





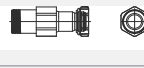

3.5 Compatible accessories

⚠ The accessories table refers to all products in the Filomuro Slim Fit range. Please check the column Combinable products for correspondence with the purchased size.

Accessory description		Combinable products	Code
Wall-mounted control panels M7 series			
Control panels			
	LED electronic control panel with touch interface, wall-mounted complete with thermostat and room temperature and relative humidity probe. Cable connection. Colour white	All	EEB749II
	LED electronic control panel with touch interface, wall-mounted complete with thermostat and room temperature and relative humidity probe with integrated WiFi module, InnovAPP. Cable connection. Colour white	All	EFB749II
	LED electronic control panel with touch interface, wall-mounted complete with thermostat and room temperature and relative humidity probe. Bluetooth connection. Colour white	All	EGB749II
Wall mounted controls smart touch series			
Control panels			
	SMART TOUCH wall mounted control panel with thermostat and room temperature and relative humidity probe. Colour black	All	EEA649II
	SMART TOUCH wall mounted control panel with thermostat and room temperature and relative humidity probe. Colour white	All	EEB649II
	SMART TOUCH wall mounted control panel with thermostat and room temperature and relative humidity probe with integrated WiFi module, InnovAPP. Colour black	All	EFA649II (1)
	SMART TOUCH wall mounted control panel with thermostat and room temperature and relative humidity probe with integrated WiFi module, InnovAPP. Colour white	All	EFB649II (1)
WALL MOUNTED STANDARD FANCOIL CONTROLS			
Control panels			
	Wall mounted control with thermostat, summer/winter and speed selectors	All	B3V151II
Network controls			
Butler			
	BUTLER: codes, accessories and price list in relevant section	All	
Hydraulic kit			
HYDRAULIC KIT			
	Couple of EUROKONUS adapters for 1/2" female connection (male fittings)	All	AI0200II
	Couple of EUROKONUS adapters for 3/4" female connection (male fittings)	All	AI0201II
	90° bended EUROKONUS connector	All	AI0203II
	Distancer kit (1 piece)	All	AI0501II
	Adaptors for flat ring	All	AI0612II

1. The control panel is connected to the device via cable. The WiFi antenna allows remote management via app.
2. Accessories can be installed and tested at the factory

	Accessory description	Combinable products	Code
	2 way valve group with manual closure	Filomuro Slim Fit XL	I20205II (2)
		Filomuro Slim Fit	I20686II (2)
	2 way valve group (water inlet valve, shut off valve and electro thermal motor)	Filomuro Slim Fit XL	V20139II (2)
	2 way valve group (water inlet valve, shut off valve and electro thermal motor)	Filomuro Slim Fit	V20687II (2)
	3 way valve group (with inlet 3 way valve, shut off valve, and electro thermal motor)	Filomuro Slim Fit	V30688II (2)
		Filomuro Slim Fit XL	V30718II (2)

1. The control panel is connected to the device via cable. The WiFi antenna allows remote management via app.
2. Accessories can be installed and tested at the factory

INSTALLATION

4.1 Preliminary warnings

- ⚠ **This section is dedicated to the Installer. The features of the installer are described in the "Recipients" p. 8 chapter.**
- ⚠ **For detailed information on the products, refer to chapter "Technical information" p. 67**
- ⚠ The installation must be carried out by the installer in accordance with national installation regulations. There is a risk of water leakage, electric shock or fire if the installation is not performed correctly.
- ⚠ During the installation, it is necessary to observe the precautions mentioned in this manual, and on the labels placed inside the equipment, as well as to adopt any precaution suggested by common sense and by the Safety Regulations in force in the place of installation.
- ⚠ Be sure to use the supplied or specified installation parts. Use of other parts may cause the unit to come to lose, water leakage, electrical shock, or fire.
- ⚠ Failure to apply the indicated rules may cause malfunctions of the appliances and relieves the manufacturer from any warranty and from any damage caused to persons, animals or property.

4.2 Reception

4.2.1 Preliminary warnings

- ⚠ on receipt check them for any damage and, if any is found, accept the goods with reservation, and keep photographic evidence of any damage found
- ⚠ In the event of damage, notify the shipper within 3 days of receipt of any damage by registered mail with return receipt, submitting photographic evidence. Similar information should be sent by fax to the manufacturer (jurisdiction will be at the Court Trento for any dispute).
- ⚠ No notice of damage will be accepted after 3 days from delivery.

- ⚠ Unpack by check the contents of individual components against the packing list.

4.2.2 Package description

The packaging is made of suitable material and carried out by experienced personnel.
All units are checked and tested and are delivered complete and in perfect conditions.
The appliance is shipped in standard packaging consisting of a cardboard sleeve and a set of expanded polystyrene protectors.

4.3 Dimensions and weights with packaging

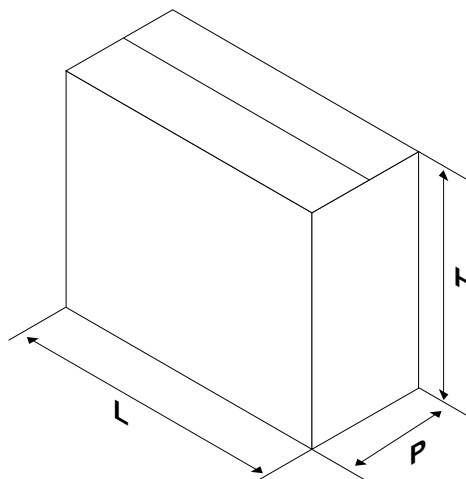

Models	m.u.	800
Dimensions and weight for shipping		
Width	mm	1420
Height	mm	450
Total depth	mm	320
Weight	kg	25,0

4.4 Handling with packaging

4.4.1 Preliminary warnings

- ⚠ The appliance must be handled only by qualified personnel, adequately equipped and with equipment suitable for the weight and dimensions of the appliance.
- ⚠ Stay clear of the area below and around it when the load is lifted off the ground.
- ⚠ Avoid dangerous situations when using a hoist to lift the appliance.
- ⚠ During transportation, the unit must be kept in vertical position.

4.4.2 Movement methods

Boxes can either be carried singularly by hand by two operators or loaded on a forklift truck even stacked.

- ⚠ Check the indications on the packaging for the number of stackable packages.

- ⚠ In manual operation it is compulsory to respect always the maximum weight per person provided for by the national laws and standards.
- ⚠ Use the handles provided on the packaging.

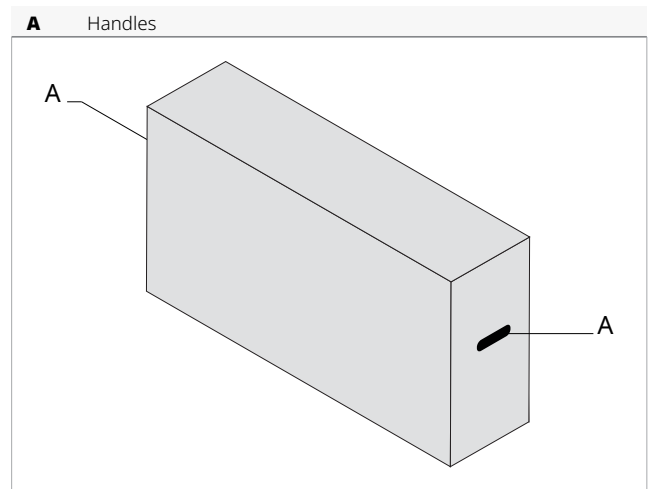

4.5 Storage

4.5.1 Preliminary warnings

- ⚠ Stored in accordance with the applicable national regulations.
- ⚠ Store the box in a closed environment protected from atmospheric agents and isolate it from the floor using planks or pallets.

- ⚠ Do not turn the packaging upside down.
- ⚠ Only place the appliance in a vertical position.
- ⚠ Store in a clean and dry place.

4.6 Unpacking

4.6.1 Preliminary warnings

- ⚠ Check that no components were damaged during transport.
- ⚠ Dispose of the packaging components following the applicable waste disposal regulations. Check for disposal arrangements with your municipality.
- ⚠ Handle with care.
- ⚠ The equipment must always be handled vertically.

- ⚠ Check if there is refrigerant inside the package using an electronic leak detector suitable for the system refrigerant. If it is present, the refrigeration circuit is likely damaged. In this case, do not install the appliance and call the Technical Assistance Centre.
- ⊖ The packing material (cardboard, staples, plastic bags, etc.) must not be dispersed or abandoned in the surrounding environment and must be kept out of children reach, as it can be dangerous.

4.6.2 Remove the package

1. Polystyrene elements

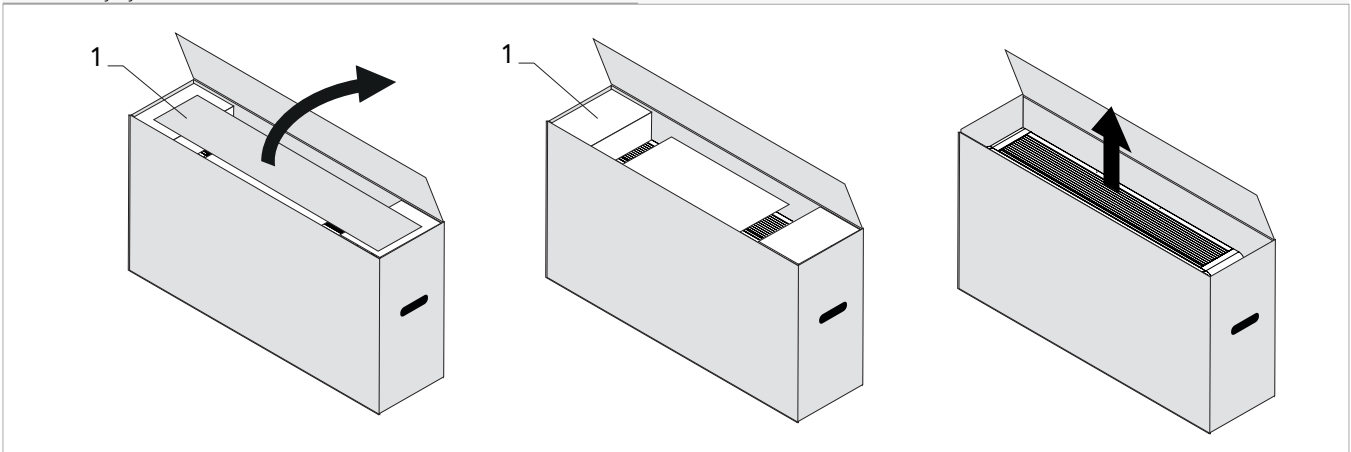

Remove the packing:

- open the cardboard packaging
- remove the polystyrene elements

- remove the accompanying components
- remove the appliance from the box

Accompanying material

They are included with the appliance, inside the packaging:

- ⚠ Check the presence of the individual components.
 - 1 installer manual of the unit
 - 1 user manual

- 1 installation template
- 2 wall mounting brackets

In case of lost, the installation template is available on the website, in the download area.

4.7 Handling without packaging

4.7.1 Preliminary warnings

- ⚠ The appliance must be handled only by qualified personnel, adequately equipped and with equipment suitable for the weight and dimensions of the appliance.

4.7.2 Movement methods

- ⚠ The unit can be moved manually for short distances. In this case it is necessary to check carefully that the weight of the unit does not exceed the regulations in relation to the number of people used.

4.8 Installation site

Position of device must be established by the system designer or other qualified professional and must take into account both technical requirements and any local laws in force.

The Filomuro Slim Fit XL fancoil has to be installed only in high position on the wall, with a maximum height of 2,2 m (except for use in Cooling only).

4.8.1 Preliminary warnings

- ⚠ Avoid installing the unit near:
 - obstacles or barriers that cause recirculation of the exhaust air
 - narrow places where the sound level of the appliance can be enhanced by reverberations or resonances
 - environments with the presence of flammable or explosive gases
 - very humid environments (laundries, greenhouses, etc.)
 - environments with aggressive atmospheres
 - solar radiation and proximity to heat sources
 - rooms subject to high frequencies

- ⚠ Do not install over heat sources.
- ⚠ Make sure that:
 - the installation site of the unit must be chosen with the utmost care to guarantee adequate protection from shocks and consequent damage
 - the wall is able to support the weight of the appliance
 - the wall section does not feature building supporting elements, pipes or power lines
 - the wall surface is perfectly levelled
 - there are no obstacles to the free circulation of air
 - the appliance must be installed in a position where it can be easily serviced
 - the safety distances between the units and other appliances or structures are scrupulously respected so that the air entering and leaving the fans is free to circulate
- ⚠ If the appliance is installed incompletely or on an inappropriate base, it could cause damage to persons or property if it should detach from its base.

⚠ The unit should not be installed in a position where the air flow is aimed directly at the people nearby.

⚠ Provide the following:

- a nearby drain for the outflow of condensate
- a compliant power supply nearby
- fixing elements suitable for the type of support

4.9 Installation mode

The assembly steps described below and their drawings refer to a version of the machine with connections on the right side.

⚠ For ideal installation and performance levels, carefully follow the instructions in the manual.

⚠ Failure to do so may cause system malfunctions and automatically voids the warranty, and relieves the constructor of any harm caused to person, animals or property.

4.10 Installation minimum distances

The clearance zones for the installation and maintenance of the appliance are shown in the figure. Established spaces are necessary to avoid barriers to airflow and allow for normal cleaning and maintenance.

⚠ Make sure that there is sufficient space to allow the panels to be removed for routine and supplementary maintenance operations.

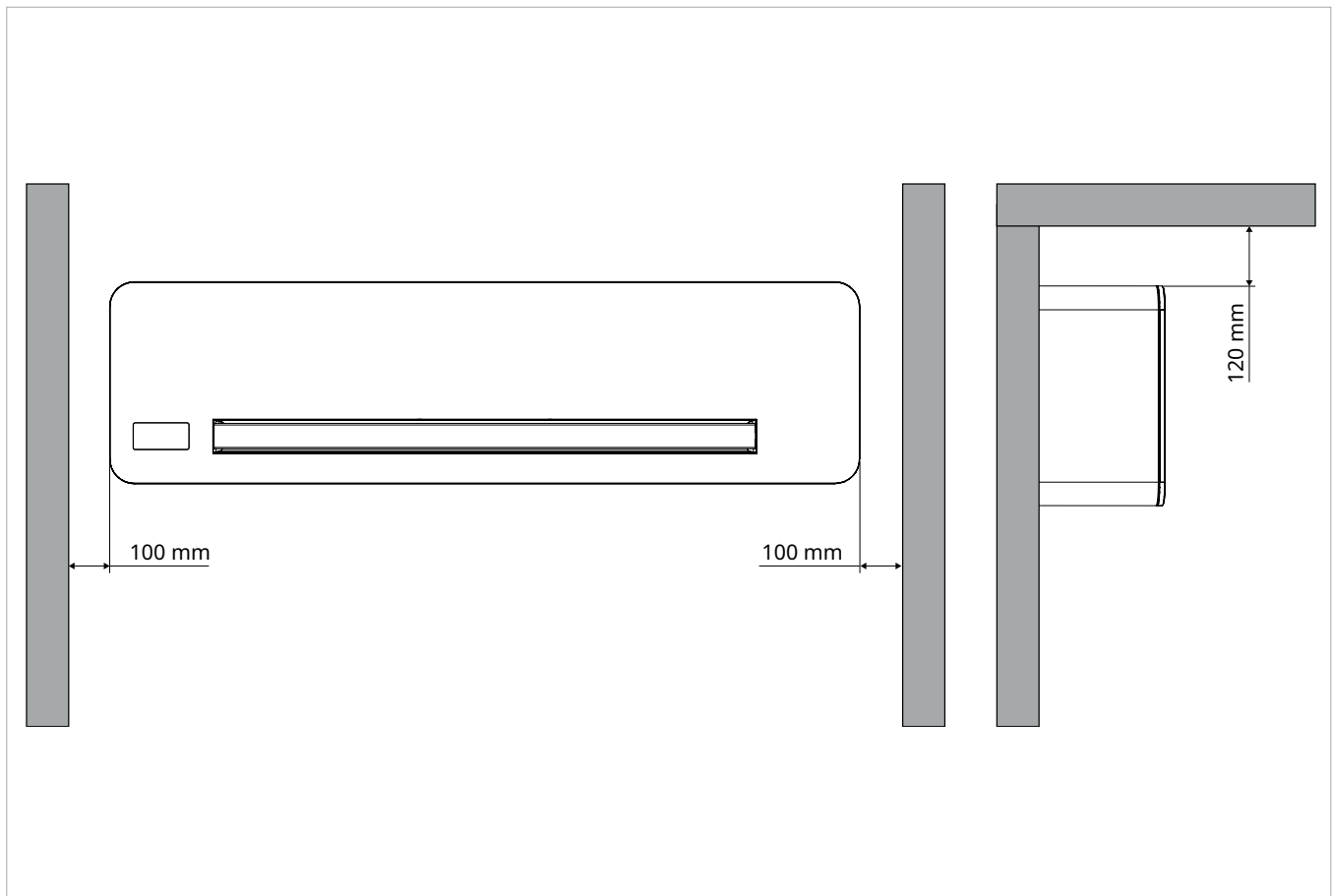

4.11 Positioning

The Filomuro Slim Fit XL fancoil has to be installed only in high position on the wall, with a maximum height of 2,2 m (except for use in cooling only).

The units are supplied with a paper template for marking the holes necessary for installation.

4.11.1 Preliminary warnings

- ⚠ Make sure that:
- the wall supports the weight of the appliance
 - the section of floor or wall does not concern piping or electrical lines
 - the functionality of load-bearing elements is not compromised

4.11.2 Device preparation

Before proceeding with the installation, it is necessary to remove some elements from the appliance.

Remove the filter

1. Air intake filter

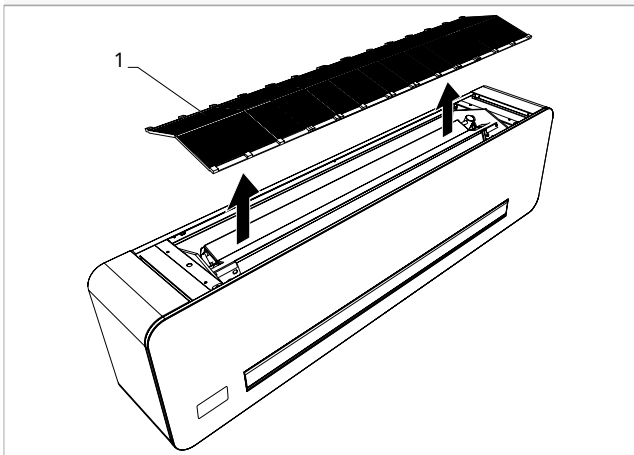

- lift the filter slightly
- rotate until the complete exit from the housing
- remove the filter

Removal of the aesthetic front panel

1. Fixing screws
2. Screw fixing bracket
3. Cosmetic front panel

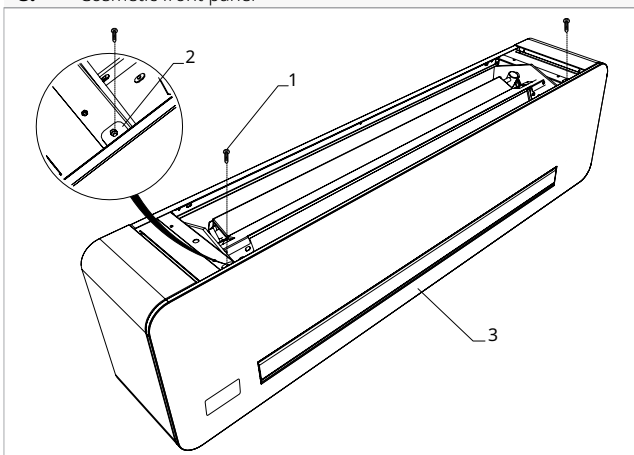

- unscrew the fixing screw

1. Aesthetic front panel

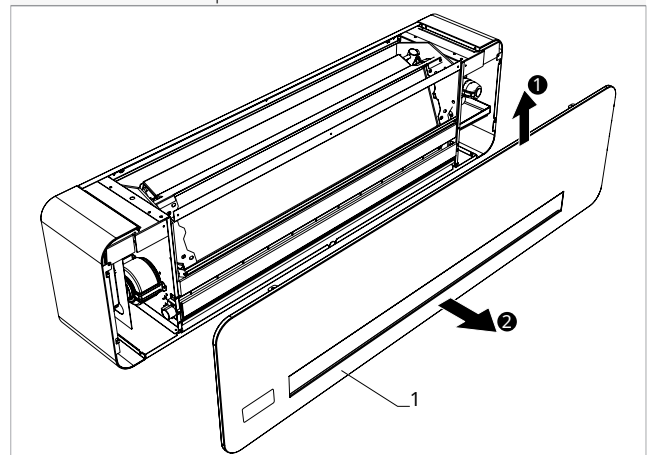

- remove the aesthetic front panel
- remove the screws on the touchpad support metal plate (if present)
- Disconnect the display connection cable

Remove the side panels

1. Fixing screws
2. Aesthetic sides

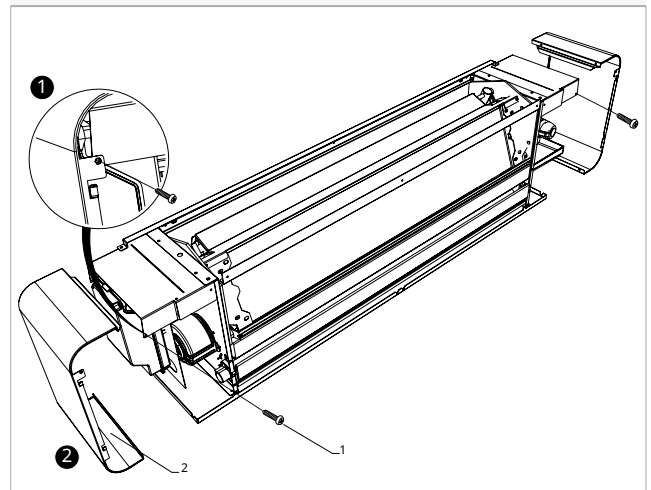

- unscrew the fixing screw
- remove the side panels

4.11.3 Installation arrangement

To install the appliance, use a recessed box to contain the connections.

⚠ If the appliance is installed later, leave the connecting pipes plentiful so as not to make joints.

1. Built-in cistern
2. Connecting water pipelines
3. Condensation drainage pipe

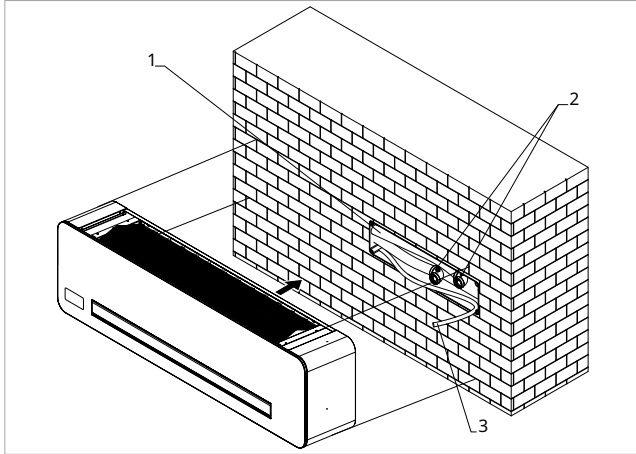

4.11.4 Positioning

⚠ The units are supplied with a paper template for marking the holes necessary for installation.

1. Minimum distance to the ceiling
2. Holes for dowels, \varnothing 8 mm
3. Electrical connection area for installation on the right
4. Lower perimeter of the unit
5. Pipe inlet area - provide flush-mounted box for hydraulic hose connection
6. Outlet for installation with 2-way valve
7. Outlet for installation with 3-way valve
8. Inlet for installation with 2-way valve
9. Inlet for installation with 3-way valve
10. Condensate drain for hydraulic connections on the right
11. Top perimeter of the unit

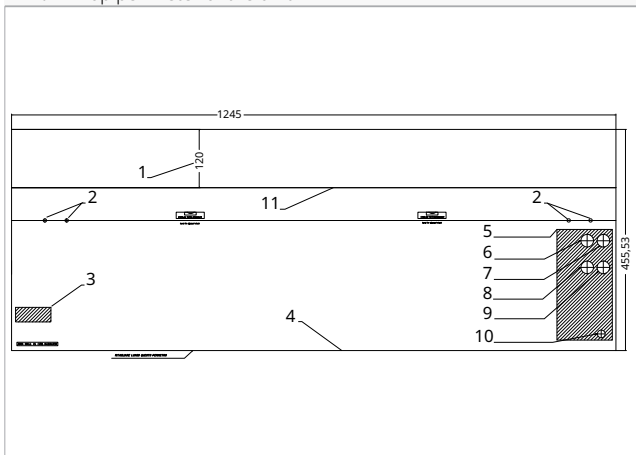

- use the paper template supplied with the device
- race the position of the fixing brackets
- drill holes in the wall

- ⚠** Hold the template in the correct position with tape.
- ⚠** Make sure that the support wall is suitable for weight of the appliance.
- ⚠** Make sure that the wall is not crossed by pipelines, load-bearing construction elements or power lines.

- A** Plugs
- B** Brackets

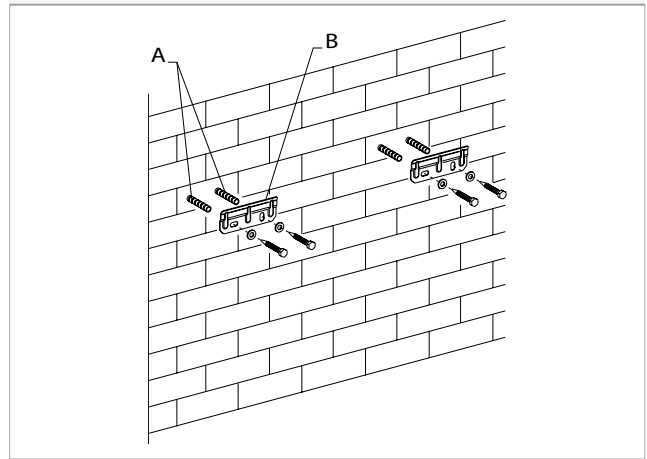

- insert the expansion plugs
- position the support brackets
- partially screw the screws

⚠ Do not fully fix the screws so that you can adjust the position of the appliance.

⚠ Use expansion plugs suitable for the chosen support wall.

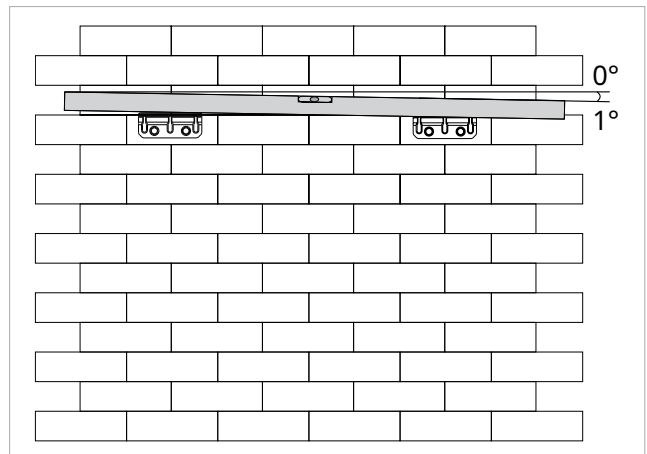

- use a leveler
- check the inclination towards the attachment side
- fix the screws

⚠ A maximum inclination of 1° towards the right side of the appliance is allowed to facilitate the drainage of condensate.

1. Fixing bracket

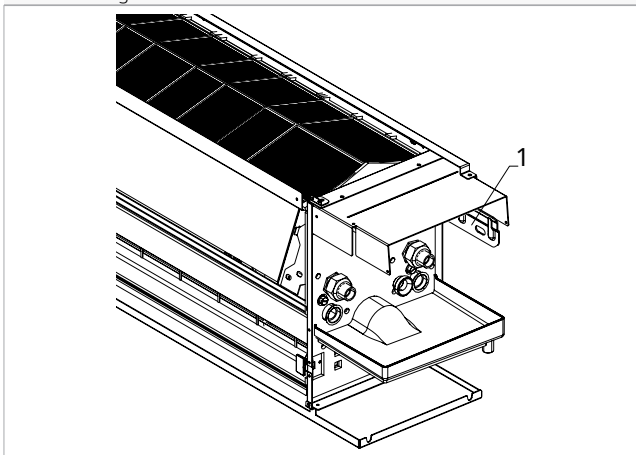

- assemble the unit
- check right attachment to the bracket

4.12 Hydraulic connections

The engineer is responsible for choosing the right water lines and their size, in accordance with good installation practices and the applicable law.

4.12.1 Preliminary warnings

⚠ Keep in mind that undersized pipelines lead to poor system operation and/or a loss of thermal and cooling performance.

- ⚠ The engineer is responsible for choosing the right water lines and their size, in accordance with good installation practices and the applicable law.
- ⚠ The hydraulic system is made by the installer and must be carried out with reference to the diagrams in this manual or on the website.
- ⚠ The hydraulic pipes connecting to the appliance must be suitably sized for the actual water flow rate required by the plant during operation. The water flow rate to the heat exchanger must always be constant.

4.12.2 Position and dimensions

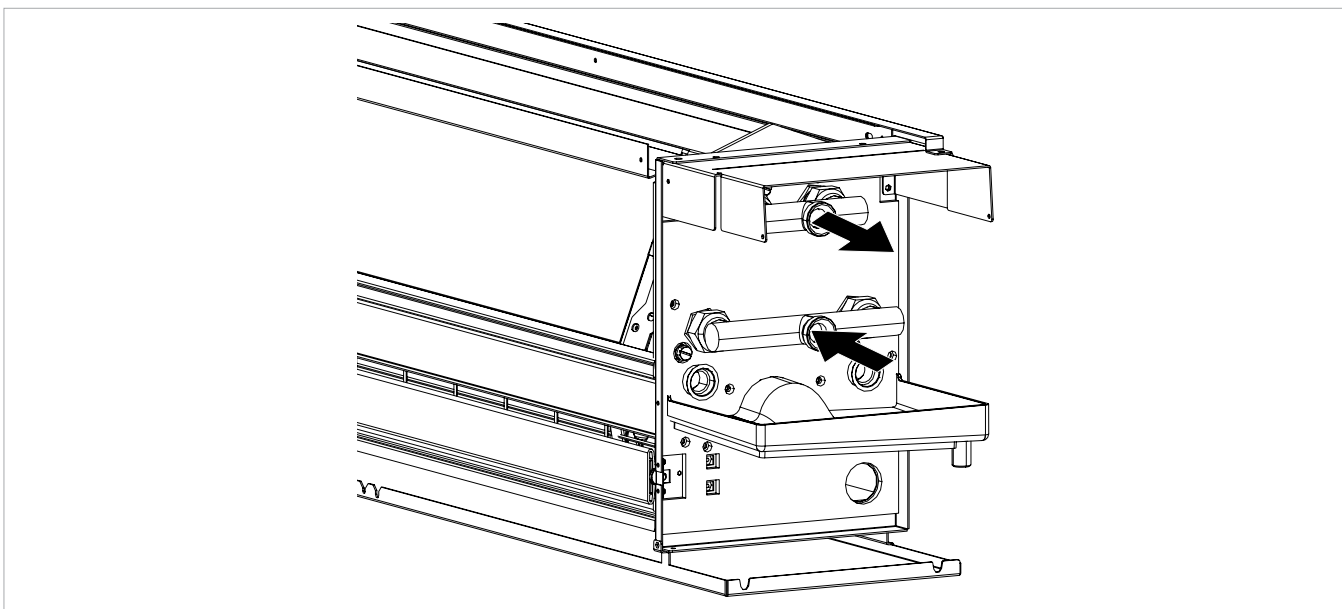

		Filomuro Slim Fit XL	
Models	m.u.	800	
Pipeline diameter	mm	18	

⚠ For dimensional information, refer to chapter "Technical information" [p. 67](#).

4.12.3 Connection to the system

To make the connections:

- hydraulic lines positioning
- use the "wrench against wrench" method
- tighten the connections
- check for leaks
- coat the connections with insulating material

- ⚠ The hydraulic lines and fittings must be thermally insulated.
- ⚠ Avoid partial insulation of the pipes.
- ⚠ Avoid over-tightening the pipes to avoid damage to the insulation.
- ⚠ Carefully check that the insulation is tight, in order to prevent the making and dripping of condensate.

4.13 Condensation drain preparation

This appliance is complete with a tray for collecting the condensation produced during operation, which must be channelled to a suitable place for drainage. The size and positioning of the drainage tube are shown below.

- ⚠ **Check the installation template for correct position of the condensate drain pipe inlet on the wall. See chapter "Installation template " p. 68.**

1. Condensate drain connection

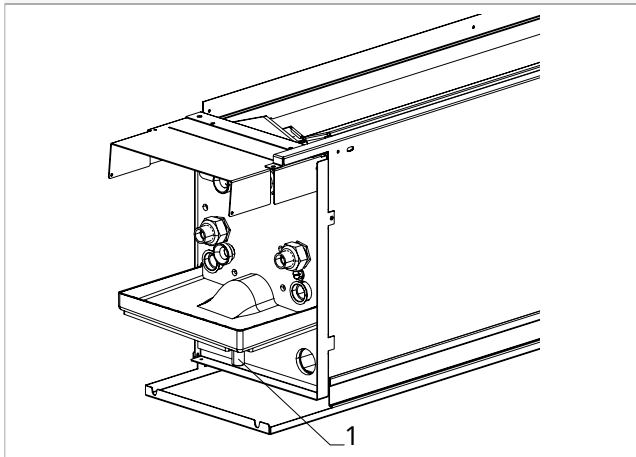

Models	m.u.	800
Product dimensions and weight		
Condensate drain connection	mm	14

4.13.1 Preliminary warnings

- ⚠ If the line flows into a container (e.g. a tank), do not close the container hermetically and avoid immersing the draining pipe into the water.
- ⚠ The hole for the condensation pipe must always slope towards the outside.
- ⚠ The exact position in which to place the pipe mouth is indicated on the template.

4.12.4 Shut-off valves

Normally, unit comes without any shut-off valve.

In other case, depending of the request, the unit can be supplied with valves already assembled or supplied separately to be mounted during installation.

- ⚠ The 2-way and 3-way motorized valves are mandatory for the correct operation of the unit.
- ⚠ The motorized valve can be omitted, inside the unit, if there is a motorized valve in the distribution manifold of the system and connected to the regulation card of the unit.
- ⚠ 2-way or 3-way motorized valves are available as accessories, see chapter "Compatible accessories" p. 12.
- ⚠ For detailed information on accessories please refer to the "Configuration accessories" p. 65 section.

- ⚠ Check that the expelled water does not cause any damage or problems to people or objects. During winter, this water may create sheets of ice outside.
- ⚠ When connecting the condensation drain, be careful not to squeeze the rubber duct.
- ⚠ If you do not want to prepare an external drainage pipe in "heat only" mode, it is advisable to close the condensate drain with a plug.

4.13.2 Positioning

- ⚠ To connect the condensate drain connection to the drainage pipe, a connection stub with a pipe length of 33.73 mm is required.

1. Condensate drain connection
2. Connecting stub

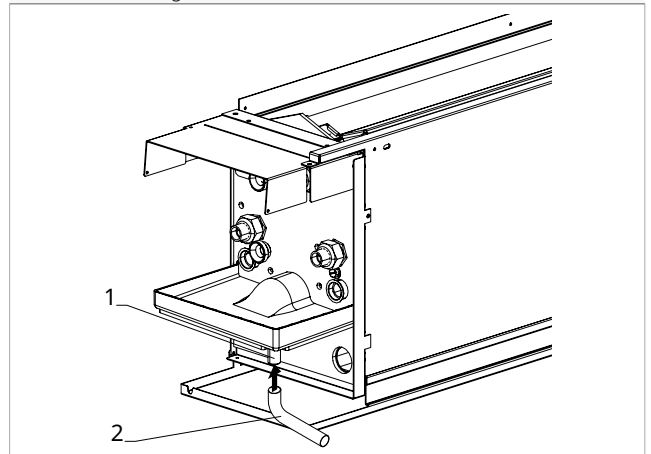

- connect a rubber drainage tube
- direct it to a suitable place for dropping
- connect the connection stub to the condensate drain connection

- 1. Drainage tube
- 2. Connecting stub

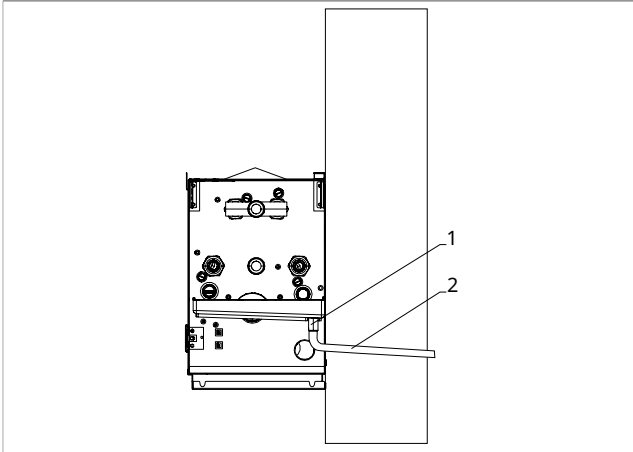

- connect the drains to the connection stub
- provide a slope never less than 1%
- insulate fitting points

- ⚠ Pay attention to the tilt of the condensate drain pipe.
- ⚠ Use plastic drainage pipes.
- ⚠ Avoid pipes made of metallic material.
- ⚠ Make sure all joints are sealed to prevent leakage of water.
- ⚠ Condensate drainage pipes must be insulated for both indoor and outdoor sections of the house to avoid condensation on the surface and/or freezing problems.

If using a jug for collecting the condensation:

- ⚠ Avoid the hermetic closure of the container.
- ⚠ Prevent the end of the drainage tube from falling below the water level.

If draining into the sewage system:

- ⚠ Make a siphon to prevent bad smells returning up the pipe towards the room. The curve of the siphon must be lower than the condensation collection pan.
- ⚠ The syphon must feature a plug in its lower part or must otherwise allow for a quick disassembly for cleaning purposes.
- ⚠ Install a pump if the drain pipe is higher than lower level of pan.

If using an open drain:

- ⚠ Make the condensate liquid flow directly onto a gutter or into a "white water" drain
- ⚠ If the condensation is not collected, it will be deposited on the support surface. The water could freeze if the outdoor temperatures are below zero, thus creating a hazard. In this case, appropriate barriers should be installed in order to prevent people from approaching the area.

4.13.3 Check

After the installation is completed:

- pour the water very slowly into the condensate drain pan
- check the right outflow

4.14 Filling the system

To fill the system:

- open the vent valves
- open all the system's shut-off devices
- slowly open the water tap

When water begins to leak out of the breather valves:

- close the vent valves
- complete system filling
- verify that you have reached the nominal pressure for the system
- close the water tap
- check the tightness of the gaskets

- ⚠ It is recommended to repeat this operation after the device has been running for a few hours.
- ⚠ Regularly check the system's pressure.

- 1. Air vent

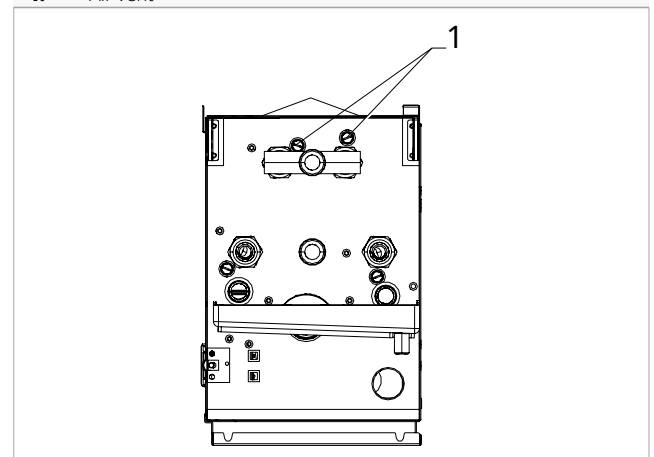

4.14.1 Mounting the thermostatic head

To mount the thermostatic head:

- tighten the head to the valve body

To facilitate the system mounting, filling and venting operations, even without electric power, the thermostatic head is supplied with a tool that keep it open.

- ⚠ Remove the tool from the thermostatic head before starting the system.

- 1. Thermostatic head
- 2. Valve body
- 3. red plastic tool

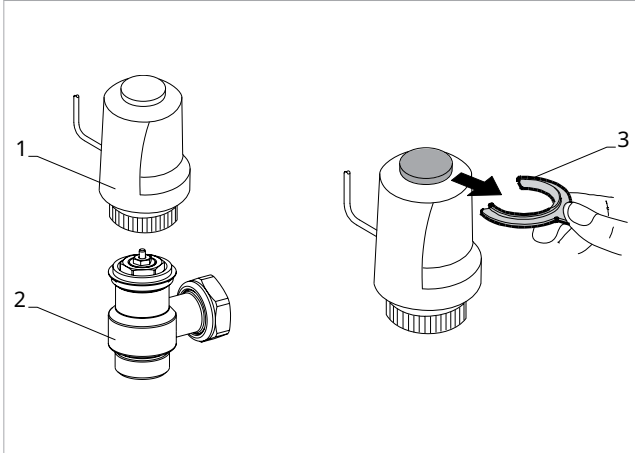

4.15 Electric connections

The device leaves the factory fully wired up and needs only the connection to the power supply, to any controls and accessories.

4.15.1 Preliminary warnings

- ⚠ All operations of an electrical nature must be carried out by qualified personnel having the necessary legal requirements, trained and informed about the risks related to such operations.
- ⚠ All connections must be made following the regulations in force in the country of installation.
- ⚠ Before carrying out any work, make sure that the power supply is switched off.
- ⚠ The unit must only be powered after all plumbing and electrical work has been completed.

Make sure that:

- the characteristics of the electric network are adapted to the absorption of the apparatus, considering also any other devices in parallel operation

- the power supply voltage and system frequency match to the values indicated on the device's plate data
- the cables must be appropriate for the type of installation in accordance with the CEI applicable standards
- the power supply is provide with protection against overload and/or short-circuit

It is required:

- connect the device an efficient ground connection
- the use of a dedicated main switch fitted with time-delay fuse or with an automatic circuit breaker switch, installed near the device
- ⚠ If you need to replace the power cable, contact only qualified staff and in compliance with the applicable national laws.
- ⚠ Disconnect the main circuit breaker before making any electrical connections and performing maintenance on the equipment.
- ⊖ It is forbidden to use gas and water pipes for grounding.

4.15.2 Power line dimensioning

For the size of the power supply cable and safety devices, use the following table.

Models	m.u.	800
Power conductor (phase+neutral)	mm ²	1,5
protective conductor section on ground	mm ²	1,5
Circuit breaker	A	2

- ⚠ The values indicated refer to a maximum line length of 15 m.

4.15.3 Access to the terminal block

To connect the power supply:

- | | | | |
|----|---------------------------|----|-----------------------------|
| 1. | Fixing screws | 3. | Cover of the electrical box |
| 2. | Terminal block for wiring | | |

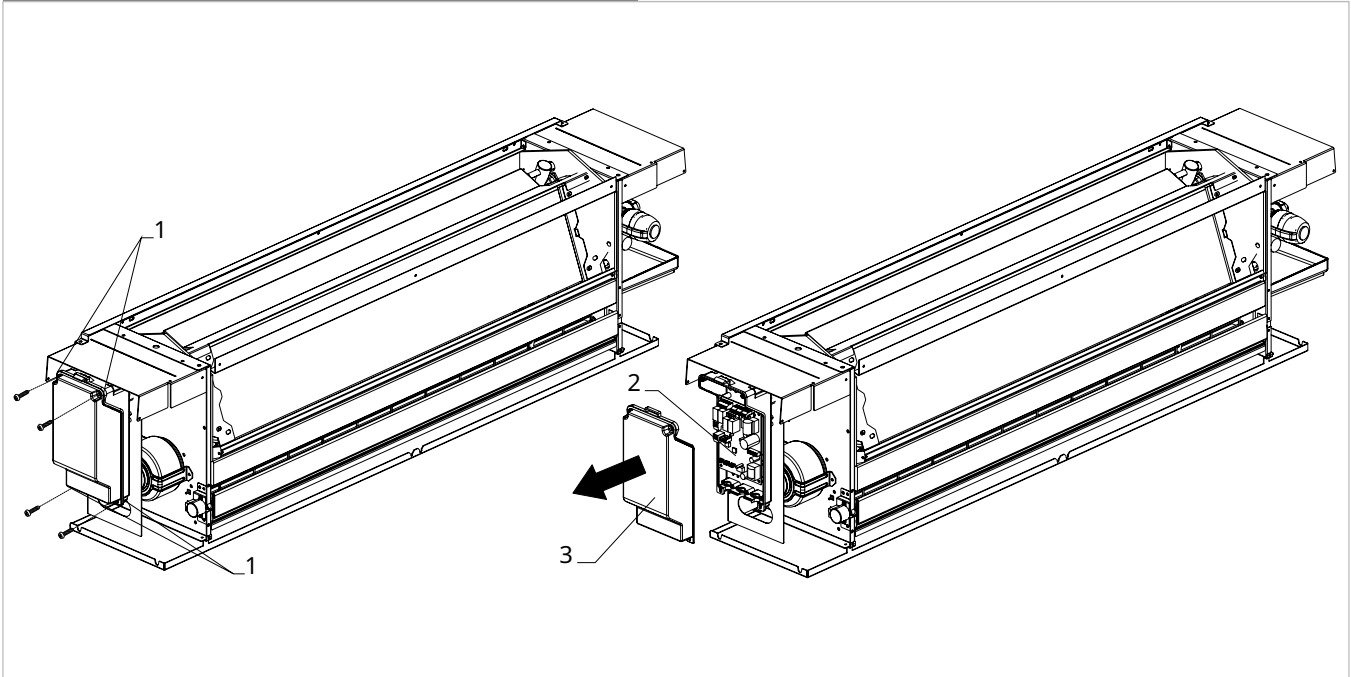

⚠ Before doing any work, make sure that the supply power is disconnect.

⚠ Access to the electrical panel is only permitted to qualified personnel.

To access:

- remove the aesthetic front panel and side panels

To access the connections:

- unscrew the fixing screws of the electric box
- remove the panel

To make the connection:

- bring the power cord to the terminal block
- making the connections

⚠ Refer to the information in the wiring diagram of the unit you are installing.

⚠ The electrical connection can be made by means of a cable installed in a flush-mounted duct in the wall (see position indicated on the template). This connection is recommended for installations of the appliance at the top of the wall.

⚠ It is necessary to check that the power supply is provided with appropriate protection against electric shorts and/or overloads

4.15.4 Electrical connection and settings

⚠ Refer to the respective section of the control used to make the electrical connections.

Touchpad and remote control. (See section "Touchpad and remote control Code ECA789" [p. 26](#))

Remote controls for M7 series wall control Cod. EEB749. (See section "M7 series control Code EEB749" [p. 30](#))

Remote control for Bluetooth wall control M7 series Cod. EGB749 (See section "M7 series control Code EGB749" [p. 39](#))

Smart Touch remote controls Cod. EEA649 - EEB649 - EFA649 - EFB649. (See section "Remote control EEA649 - EEB649 / EFA649 - EFB649" [p. 48](#))

Remote controls (Fixed speeds). (See section "Fixed speed remote controls Code B3V151" [p. 55](#))

0-10 V connection. (See section "0-10 V connection" [p. 60](#))

TOUCHPAD AND REMOTE CONTROL CODE ECA789

5.1 Interface

The touchpad control is supplied as standard on board the unit and does not require any connections.

1. Display area
2. Keys area

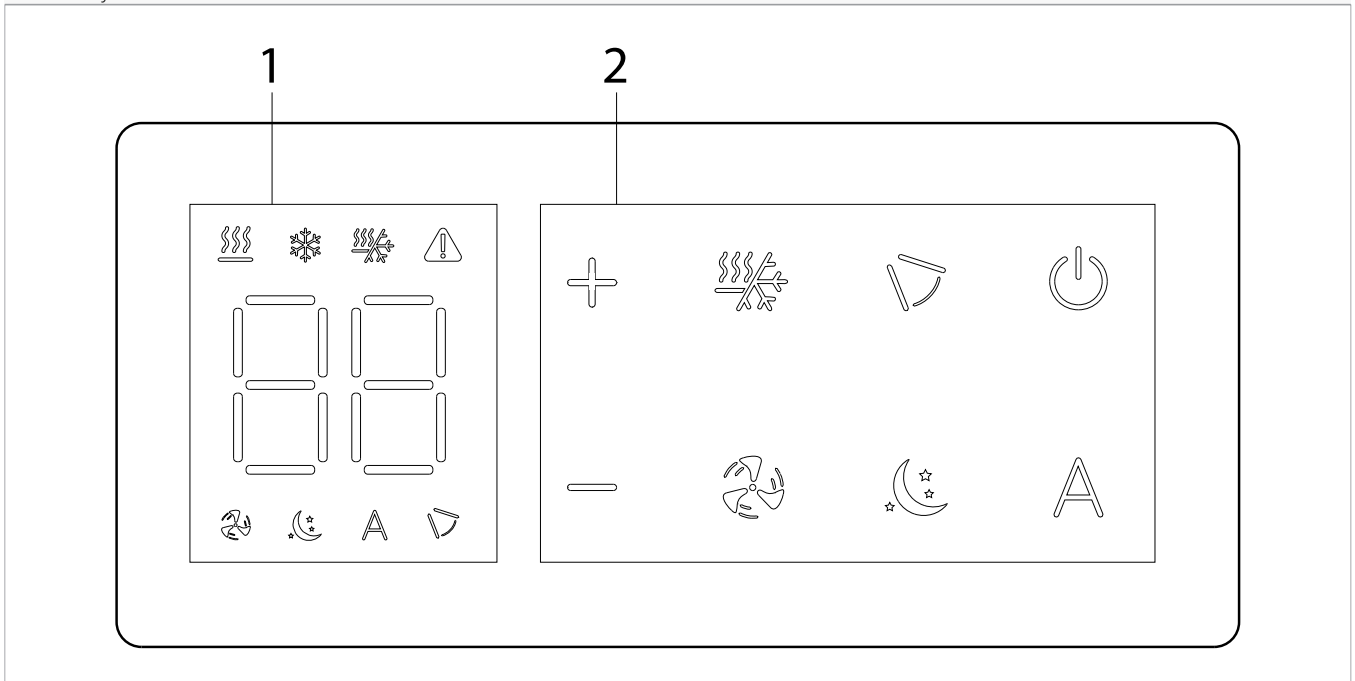

5.2 Printed circuit board ECA789

The PCB is included in the supply.

M1	Fan motor DC Inverter
PE	Earth connection
L-N	230 V/50 Hz electrical power supply connection
Y1	Water electrovalve (voltage output 230 V / 50 Hz / 1 A)
CH/C1	Cooling request contact (for example chiller or reversible heat pump). Activated in parallel with the solenoid valve output (Y1) with 1 minute delay when the fancoil is in cooling mode and is on call (potential-free contact max. 1 A).
BO/C2	Heating request contact (for example boiler or heat pump). Activated in parallel with the output of the solenoid valve (Y1)

CP	Presence contact (normally open)
SM	Step Motor
IN1	Input for potential-free contact 1
AIR/T1	Air temperature probe
H2/T2	Water temperature probe
DU	Touchpad
PU	Electronic board on the unit
PSM	Electronic board for step motor connection

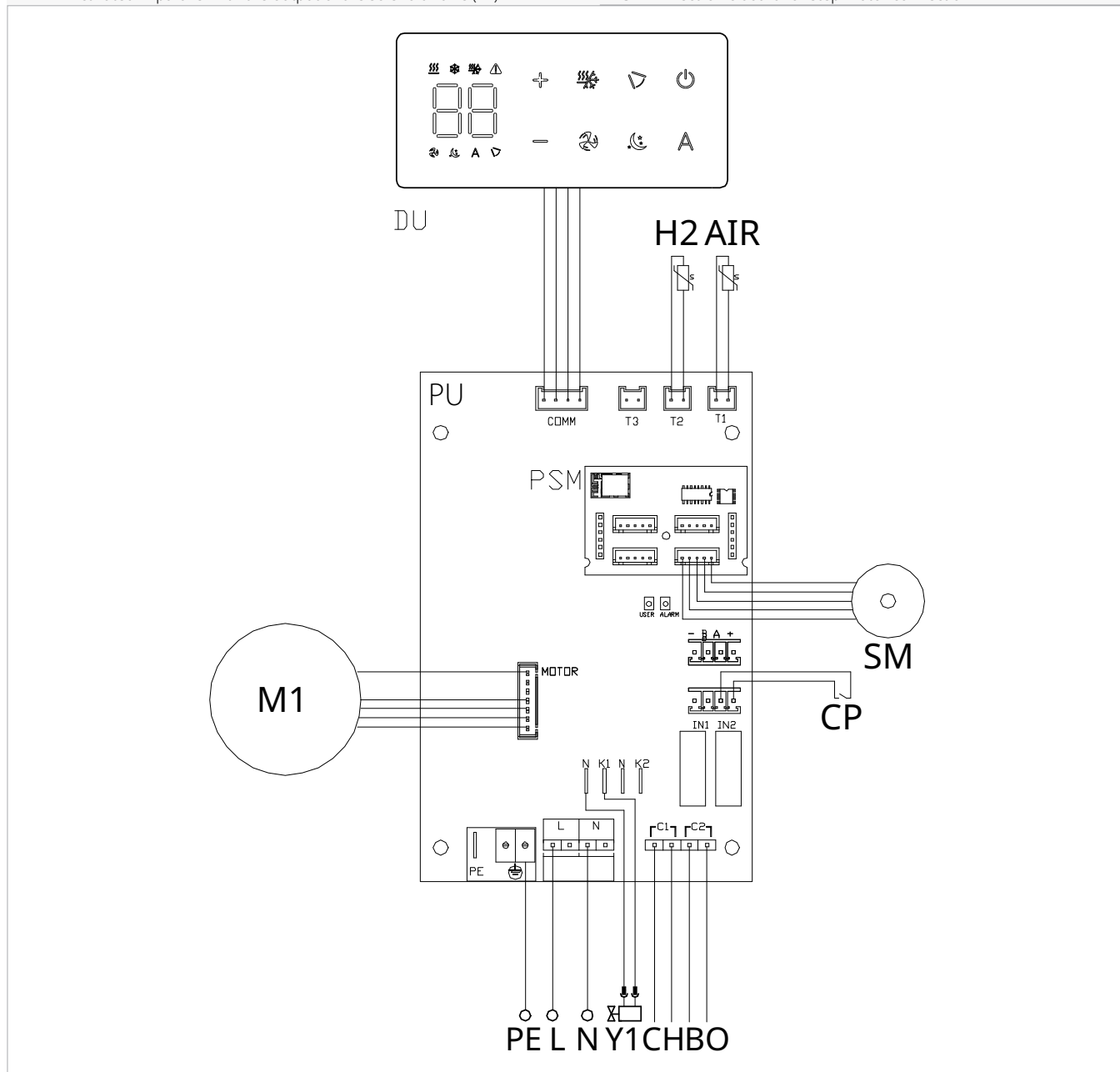

Through the water temperature probe H2/T2 (10 k Ω) located in the thermowell on the unit's coil, the temperature setpoints for fan stop are controlled:

- minimum temperature in heating mode (30 °C)
- maximum temperature in cooling mode (20 °C)

⚠ The printed circuit board provides for operation without a water probe. In this case, the fan stop thresholds are ignored.

5.3 Connections

Presence contact CP

Through this contact it is possible to connect an external device that inhibits the operation of the device, for example:

- opening window contact
- remote on/off
- infrared presence sensor
- enabling badge
- remote change of season

Function

The contact is normally open.

- when closing the CP contact, connected to a potential-free contact, the device switches to stand-by mode
CP appears on the display.
- At the touch of a button on the display the symbol  flashes.

- ⊖ It is forbidden to connect in parallel the CP input to one of another electronic board. Use separate contacts.

The CP presence contact can be configured for heating and cooling operation via the "To select digital input" [p. 29](#) settings menu item (digital input).

5.4 Functions



- ⚠ The keys of the remote control and touch-screen display perform the same function.

5.4.1 Basic menu

To access the basic menu



- with the display off, hold down  for 10 seconds

The device turns on and  appears

- keep pressed until the indication  appears
- release the  key

The symbol  appears

To navigate in the menu

- use the icons  





To select a menu item and to confirm the changes made

- press the icon  *Confirming the change takes you to the next item.*

To exit the menu



- press the icon  for 10 seconds
- or wait 30 seconds the automatic shutdown

To set the air probe regulation

- select 
- press  to change settings
- increase or decrease the value with the icons  
- press  to confirm
*By default it is set to 0.
The range of settings is from a minimum of -9°C to a maximum of +9°C.*

Scale

To change the temperature unit of measure

- select 
- press  to change settings
- select °C or °F
- press  to confirm
By default the temperature unit of measure is °C.

Menu items

ot: AIR probe offset (air probe setting)

CF: Scale

ub: Buzzer volume





Set AIR probe offset

- ⚠ The set value changes by 1 °C each press of the  and  buttons.

Scale

Adjusting buzzer volume

To change the volume

- select 
- press  to change settings
- increase or decrease the value with the icons  
- press  to confirm
The volume setting range is from 00 (min) to 03 (max).



- ⚠ The volume changes after confirm the modification.



5.4.2 Advanced Menu

- ⚠ **To access the Setup menu, it is necessary to access the Basic menu. See section "Basic menu" [p. 28](#).**



The special functions menu can be accessed via the control panel.

To access the setup menu

- from the basic menu press 
Appears .

- press the  key once
Appears .
- press  to confirm and log in
This takes you to the settings menu.



To navigate in the menu

- use the icons  

To select a menu item and to confirm the changes made

- press  for 2 seconds
Confirming the change takes you to the next item.

To exit the menu

- press  for about 10 seconds
Appears .
- press  for about 10 seconds
The display turns off.
- or wait 30 seconds after the last action
The display is switched off automatically.

 After 30 seconds from the last action the control goes out and the settings is memorized.

Menu items

Ad: Not used

of: Options for digital output



UC: Not used

Ac: Not used



Ah: Not used

Fr: Not used

To select digital input**To change the digital input**

- select 
- press  to change settings
- select CP for contact presence (default)
- select CO to cooling open
- select CC to cooling close
- press  to confirm
By default digital input is set to CP.

 For return to the default settings, set the digital input to "CP".

 By selecting one of the other inputs (CO,CC) the seasonality is locked. It is not possible to modify it through the key  of the control.

5.4.3 Error signals

The PCB has a status LED.

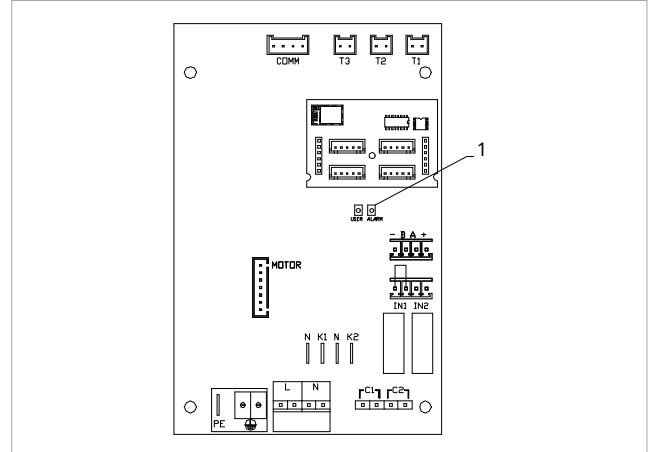
1. LED

 The flashing LED indicates errors.

 It is possible to verify the meaning of the LEDs by means of the error code displayed on the touchpad.



 To identify the error, please refer to "Visualization of alarms on display" [p. 29](#).

 With the LED on and no indication on the display, it is indicated that there are no errors.

5.4.4 Visualization of alarms on display

 In the event of a malfunction, the display shows an alarm code.

 In the event of an alarm, the device still maintains active functions.

- E1 Room temperature probe AIR/T1 disconnected or faulty
None of the modes can be activated.
- E2 Faulty internal fan motor or disconnected
None of the modes can be activated.
- E3 Water temperature probe H2/T2 disconnected or failure
None of the modes can be activated.
- CE Communication error
Errors in the communication between the touchpad control and the board. None of the modes can be activated.
The symbol  appears to indicate unsuitable radiant water.
-  lampeggiante Incorrect water temperature
In heating mode, the water temperature is below 30 °C.
-  lampeggiante Incorrect water temperature
In cooling mode, the water temperature is above 20 °C.

M7 SERIES CONTROL CODE EEB749

6.1 Interface

- 1. Display area
- 2. Keys area

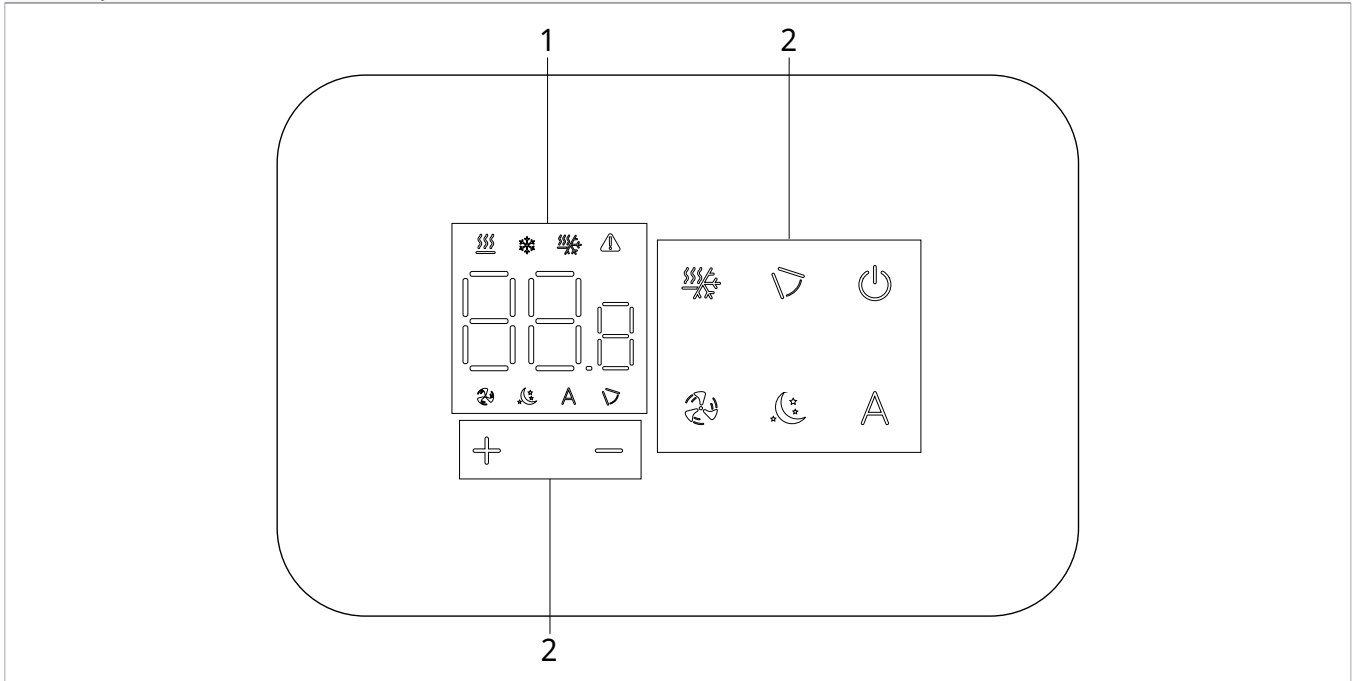

6.2 Installation

6.2.1 Description

the wall-mounted remote control is an electronic LED thermostat with a touch interface, with the possibility of control over multiple appliances equipped with the same electronic board. It is equipped with a temperature and humidity probe.

⚠ The control can control up to a maximum of 16 units.

6.2.2 Mounting

⚠ The control panel for wall control is to be installed inside a 503 electrical box.

⚠ A wall must be prepared to accommodate the 503 electrical box before installing the wall control.

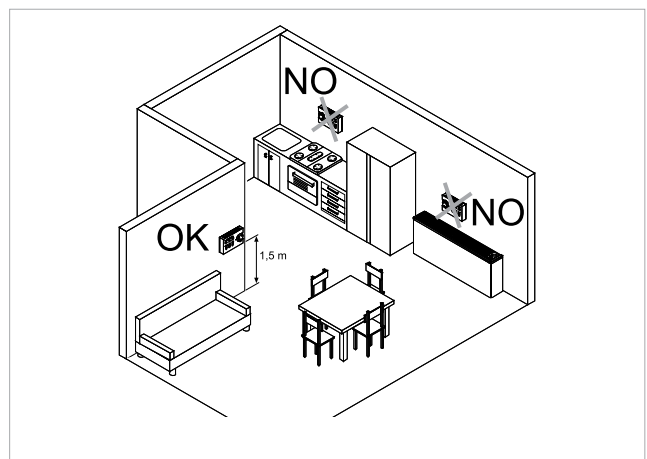

The wall-mounted remote control must be installed:

- on internal walls
- at a height of about 1,5 m from the floor
- away from doors or windows
- away from heat sources (heaters, convectors, stoves, direct sunlight)

⚠ The wall control is provided inside the package already assembled.

1. Base of control
2. Wall-mounted control panel

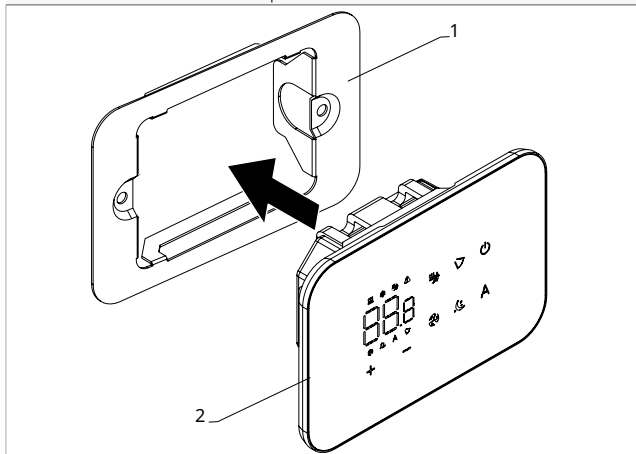

- Close the control panel

⚠ Pay attention not to crush the conductors when you close the control.

Before wall installation:

- separate the control base from the control panel

1. Fixing screws
2. Base of control
3. Holes for fixing to electrical box
4. Electric box 503

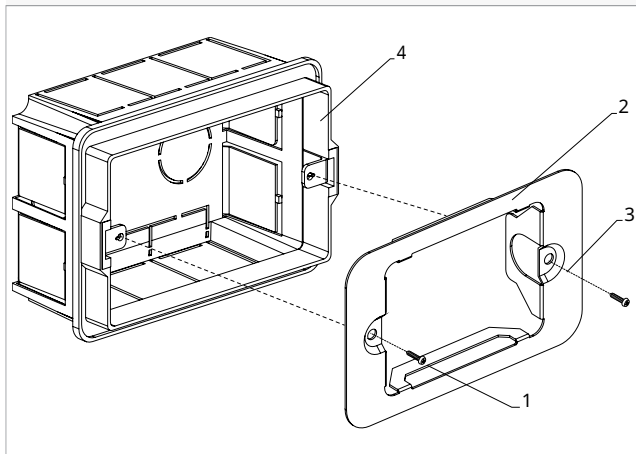

For wall mounting of the control panel:

- fix the control base to the electrical box 503 with screws
- connect the electrics

⚠ Before making the connections, please verify that the control terminal block is on the right-hand side.

1. Electric box 503
2. Base of control
3. Wall-mounted control panel

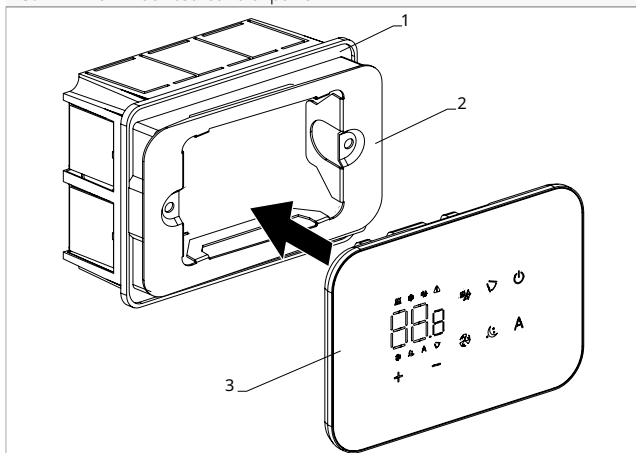

6.3 Single connection diagram

M1	Fan motor DC Inverter
SM	Step Motor
PE	Earth connection
L-N	Power supply connection 230 V / 50 Hz / 1 A
Y1	Water electrovalve (voltage output 230 V / 50 Hz / 1 A)
CH/C1	Cooling request contact (for exemple chiller or reversible heat pump). Activated in parallel with the solenoid valve output (Y1) with 1 minute delay when the fancoil is in cooling mode and is on call (potential-free contact max. 1 A).
BO/C2	Heating request contact (for exemple boiler or heat pump). Activated in parallel with the output of the solenoid valve (Y1)

+BA-	Serial connection for wall-mounted remote control (respect polarisation AB)
IN1	Potential-free input 1(not active)
H2/T2	Water temperature probe
CP	Presence contact (normally open)
LU	Electronic board for pairing control and device
PU	Electronic board on the unit
PSM	Electronic board for step motor connection

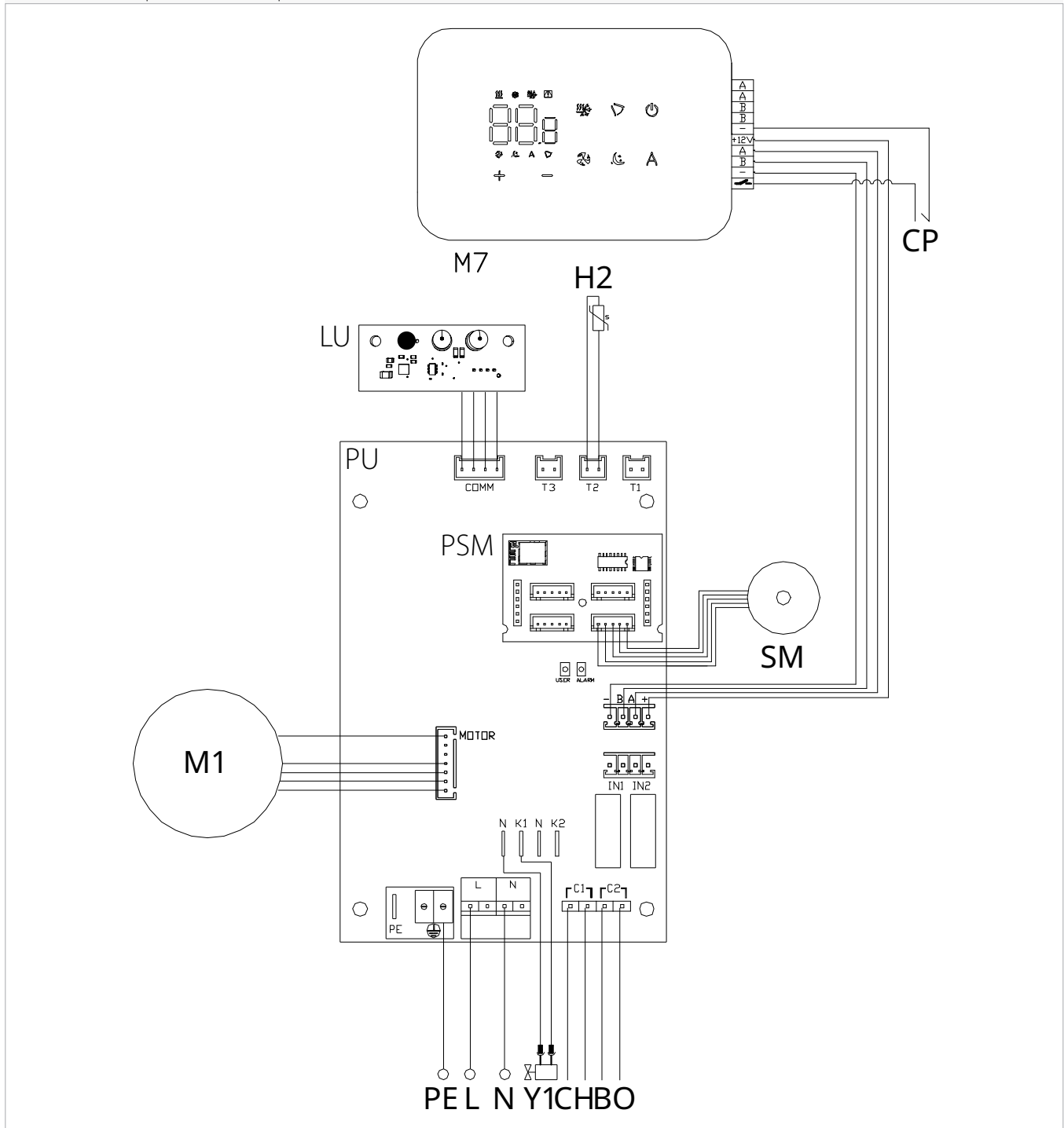

6.5 Connections

6.5.1 Preliminary warnings

⚠ The terminals for connecting the control panel and the presence contact CP are placed in a plastic bag and positioned inside the cover of the electrical box.

1. Terminal blocks

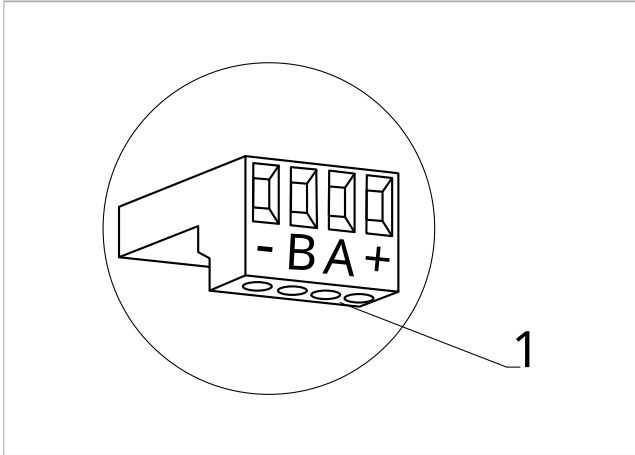

The terminals accept:

- rigid or flexible wires with a 0.2 to 1 mm² cross-section
- rigid or flexible wires with 0,5 mm² cross-section if two wires are connected to the same terminal block
- rigid or flexible wires with 0,75 mm² cross-section if the wires have wire end ferrules with a plastic collar

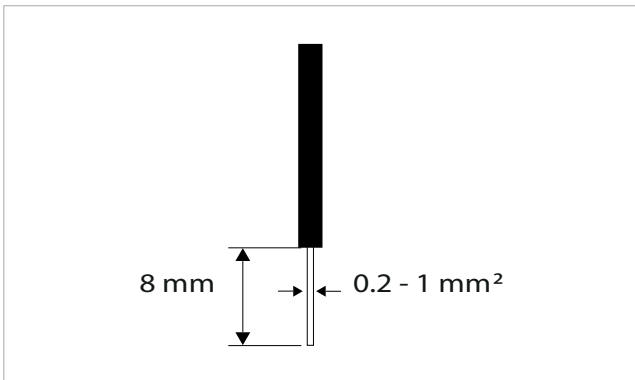

To connect the cables:

- strip 8 mm of the wire
- if the wire is rigid, you can insert it easily whereas
- if it is flexible, use appropriate crimp terminals
- push the wire completely in
- check the right fixing by pulling it gently

6.5.2 Control Panel

⚠ The control panel for wall control must be ordered separately.

Terminal block position:

1. Terminal block (Back view panel)

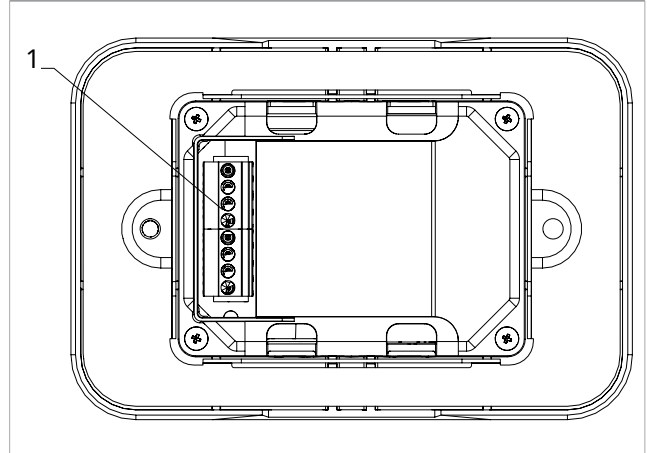

1. Terminal blocks

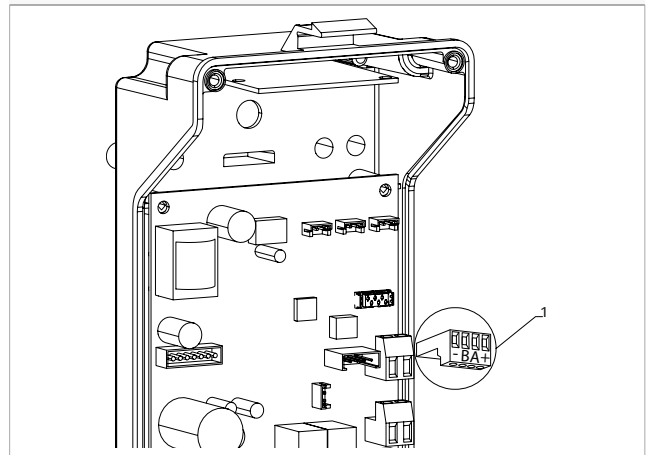

To connect the wall control panel to the board:

- connect the power supply cables to the + - terminals
- connect the ModBus serial connection cables to terminals A and B

6.5.3 Presence contact CP

Trough this contact it is possible connect an external device that inhibits the operation of the device, for example:

- opening window contact
- remote on/off
- infrared presence sensor
- enabling badge
- remote change of season

Function

The contact is normally open.

- when closing the CP contact, connected to a potential-free contact, the device switches to stand-by mode

CP appears on the display.

- At the touch of a button on the display the symbol ⚠ flashes.

⊖ It is forbidden connect in parallel the CP input to one of another electronic board. Use separate contacts.

The CP presence contact can be configured for heating and cooling operation via the "To select digital input" settings menu item (digital input).

6.5.4 RS485 Serial Connection

The wall-mounted remote control can be connected through a RS485 serial line to one or more device, for a maximum of 16.

The devices must be equipped with an electronic board suitable for remote control.

For the connection:

- follow the indication on the connection diagram





- connect respecting the indication A and B

- ⚠ Use a bipolar shielded cable suitable for the RS485 serial connection with a minimum section of 0,35 mm².
- ⚠ Keeping the bipolar cable separate from power supply cables.
- ⚠ Chase out the wall in order to minimize the length of the leads.
- ⚠ Complete the line with the 120 Ω resistance.
- ⊖ It is forbidden make star connections.



6.6 Functions

6.6.1 Basic menu

To access the basic menu

- with the display off, hold down  for 10 seconds
The device turns on and  appears
- keep pressed until the indication  appears
- release the  key
The symbol  appears

To navigate in the menu

- use the icons  

To select a menu item and to confirm the changes made

- press the icon 
Confirming the change takes you to the next item.

To exit the menu

- press the icon  for 10 seconds
- or wait 30 seconds the automatic shutdown

- ⚠ After 30 seconds from the last action the control goes out and the settings is memorized.

Menu items

ot: AIR probe offset (air probe setting)

ur: Value read by the R.H. sensor

ut: Probe Offset PT4

us: Humidity setpoint





ui: Humidity hysteresis

CF: Scale

ub: Buzzer volume

Set AIR probe offset





To set the air probe regulation

- select 
- press  to change settings
- increase or decrease the value with the icons  
- press  to confirm
*By default it is set to 0.
The setting range is from a minimum of -12.0 °C to a maximum of 12.0 °C.*

Set probe offset RH





- ⚠ Modify only after real deviations from an actual measurement with professional instrumentation have been established.

To set the RH probe regulation

- select 
- press  to change settings
- increase or decrease the value with the icons  
- press  to confirm





Set the humidity setpoint

To set the humidity setpoint

- select 
- press  to change settings
- increase or decrease the value with the icons  
- press  to confirm
The setting range is from 20.0% to 90.0%.



Setting the humidity hysteresis

To set the humidity hysteresis

- select 
- press  to change settings
- increase or decrease the value with the icons  
- press  to confirm
The setting range is from 1 (min) to 30 (max).





Scale

To change the temperature unit of measure

- select 
- press  to change settings
- select °C o °F
- press  to confirm
By default the temperature unit of measure is °C.

Adjusting the volume

To change the volume

- select 
 - press  to change settings
 - increase or decrease the value with the icons  
 - press  to confirm
- The volume setting range is from 00 (min) to 03 (max).





 The volume changes after confirm the modification.

6.6.2 Advanced Menu



 **To access the Setup menu, it is necessary to access the Basic menu. See section "Basic menu" p. 35.**

The special functions menu can be accessed via the control panel.

To access the setup menu

- from the basic menu press 
 - Appears 
 - press the  key once
 - Appears 
 - press  to confirm and log in
- This takes you to the settings menu.



To navigate in the menu

- use the icons  

To select a menu item and to confirm the changes made

- press  for 2 seconds
- Confirming the change takes you to the next item.

To exit the menu

- press  for about 10 seconds
- Appears 
- press  for about 10 seconds
- The display turns off.
- or wait 30 seconds after the last action
- The display is switched off automatically.

 After 30 seconds from the last action the control goes out and the settings is memorized.

Menu items

Ad: Not used

of: Options for digital output

rH: Radiant heating options with R20

rC: Radiant cooling options with R20

UC: Not used



Ac: Not used

Ah: Not used



Fr: Not used

To select digital input

To change the digital input

- select 
 - press  to change settings
 - select CP for contact presence (default)
 - select CO to cooling open
 - select CC to cooling close
 - press  to confirm
- By default digital input is set to CP.

 For return to the default settings, set the digital input to "CP".

 By selecting one of the other inputs (CO,CC) the seasonality is locked. It is not possible to modify it through the key  of the control.

Set radiant options in heating with R20

 To change the rH function, it is necessary to have the accessory MZS - Single zone module for radiant system, code EG1028II.

 To change the settings, please refer to the Instruction Sheet of the accessory MZS - Single zone module for radiant system, code EG1028II.



Set radiant options to cooling with R20

 To change the rC function, it is necessary to have the accessory MZS - Single zone module for radiant system, code EG1028II.

 To change the settings, please refer to the Instruction Sheet of the accessory MZS - Single zone module for radiant system, code EG1028II.

6.6.3 Pairing of control and unit

To pair the control with the unit

- with control switched on, at the same time press  and  for about 10 seconds
- In the display area, where the setpoint is indicated, appears the number of connected devices.
The displayed value flashes.

1. Red LED
2. Green LED
3. Black button
4. Electrical box

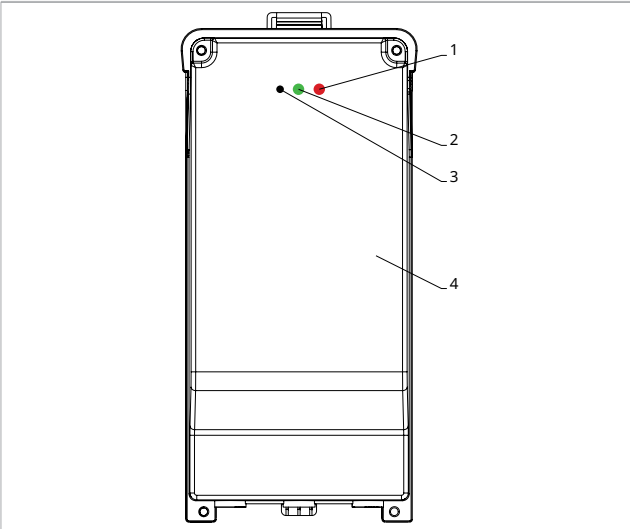

On the electrical box on the unit

- press the black button for 3 seconds
The green LED flashes.
The red LED is on.
- wait for the procedure to complete
The green LED stops flashing.

On the wall mounted control panel

- *Appear the number assigned to the fancoil.*
Then appears the number of connected devices.
- press to exit the menu

Reset pairing

⚠ To reset the pairing settings, it is first necessary to access the "Basic menu" [p. 35](#).

To reset pairing settings

- access the basic menu
- press
- press
- *All the way to the menu.*
- press

To reset a single fancoil

- *Appears*
- press
- *Appears*
- press to access the menu
- use the icons to move inside the menu
The assignment numbers assigned to the fancoils appear.
- select the fancoil to be reset
- press to confirm
 appears, with an acoustic signal.
The device is removed.

To exit the setting

- press for 5 seconds
Exit the setting.
Back to menu 02.

To reset all fancoils

- *Appears*
- press until appears
Appears
- press to access the menu
- use the icons to move inside the menu
- select No to maintain all fancoils
- select Yes to reset the fancoils
- press to confirm

LED interface operation on the electrical box

If the device is being paired

The green LED flashes.

If the device is paired and functioning

The green LED is on.

If the device has not been paired and is not functional

The green LED is off.
The red LED is on.

If the device is in alarm status

The red LED flashes.

⚠ The red LED flashes according to the type of alarm. To check the alarm type, please refer to the following "Error signals" [p. 37](#) section.

If communication with the remote control is missing

The green and red LEDs will flash once every second.

6.6.4 Error signals

The PCB has a status LED.

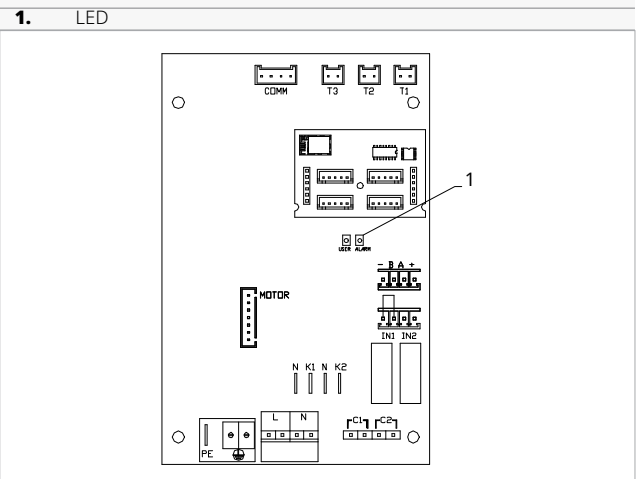

⚠ Once the pairing has been completed, the red LED on the cover of the electrical box performs the same functions as the LED on the board on the unit.

⚠ The flashing LED indicates errors.

⚠ With the LED on and no indication on the display, it is indicated that there are no errors.

LED signals

- Led flashing
Errors to be shown on the display.

- LED off
Remote control switched off.
- LED on
Wall control on and no alarm present.
- LED continuous flashing with pause between flashes
Unsuitable water temperature alarm.
- LED 2 flashes / pause
Internal fan motor alarm faulty or disconnected.
- LED 3 flashes / pause
Alarm for water temperature probe H2/T2 disconnected or faulty.
- LED 6 flashes / pause
Communication error alarm with wall control panel.





6.6.5 Alarm display on wall control panel

 In the event of an alarm, the device still maintains active functions.

 The symbol  is displayed on the wall control panel to indicate alarms.

 **To access the Setup menu, it is necessary to access the Basic menu. See section "Basic menu" p. 35.**

To visualise errors on the wall control panel

- access the basic menu
- press 
Appears .
- press 
Appears .
- press  to access the menu
Then the number assigned to the fancoil appears and then the error is displayed.

Alarms displayed on the wall control panel

- E2 Faulty internal fan motor or disconnected
None of the modes can be activated.
- E3 Water temperature probe H2/T2 disconnected or failure
None of the modes can be activated.
- E8 Communication error
Error in the communication between the wall control panel and the fancoil. None of the unit's functions can be activated.
- h2o Incorrect water temperature
*In heating mode, the water temperature is below 30 °C.
In cooling mode, the water temperature is above 20 °C.*

 Error E8 is displayed without the error display procedure on the wall control panel.

M7 SERIES CONTROL CODE EGB749

7.1 Interface

1. Display area
2. Keys area

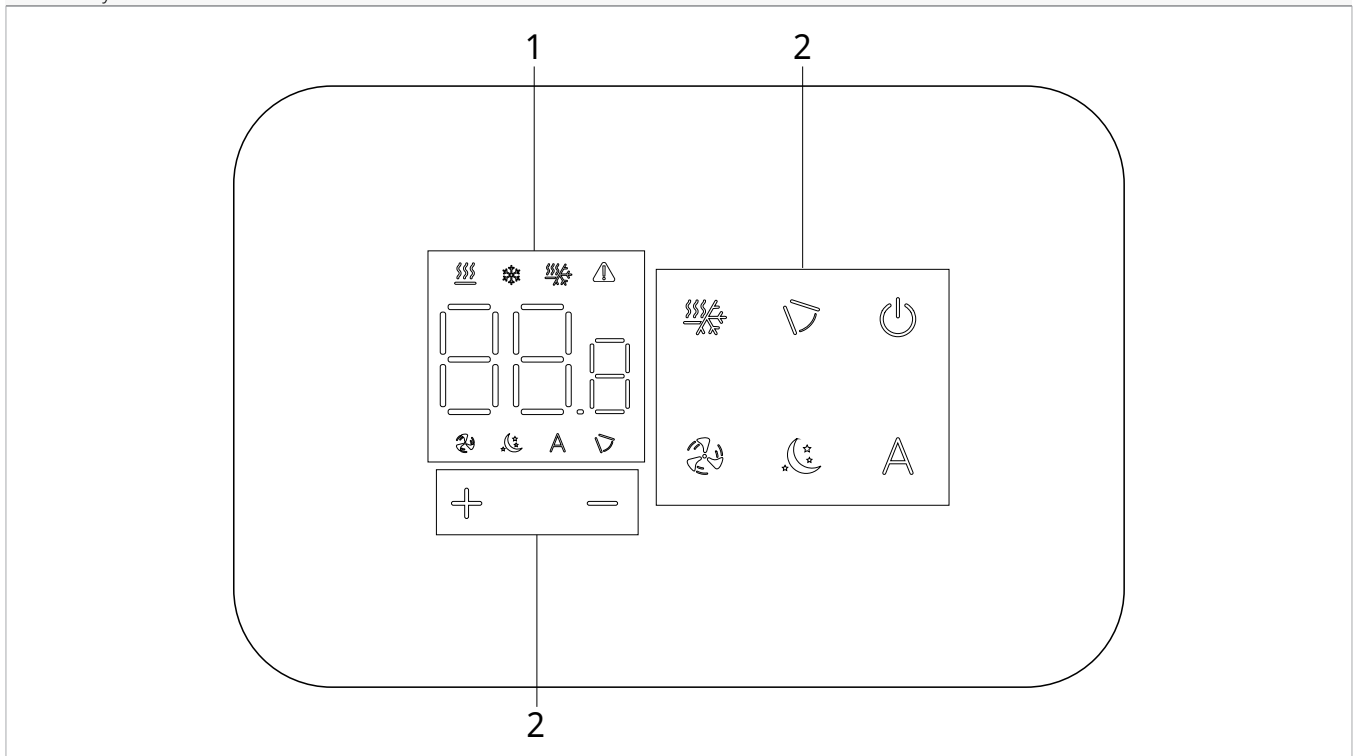

7.2 Installation

7.2.1 Description

the wall-mounted remote control is an electronic LED thermostat with a touch interface, with the possibility of control over multiple appliances equipped with the same electronic board. It is equipped with a temperature and humidity probe.

- ⚠ The control can control up to a maximum of 16 units.

7.2.2 Mounting

- ⚠ The control panel for wall control is to be installed inside a 503 electrical box.
- ⚠ A wall must be prepared to accommodate the 503 electrical box before installing the wall control.

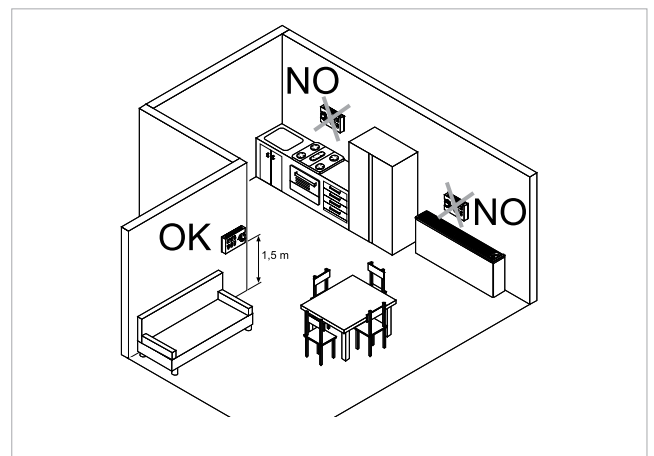

The wall-mounted remote control must be installed:

- on internal walls
- at a height of about 1,5 m from the floor
- away from doors or windows
- away from heat sources (heaters, convectors, stoves, direct sunlight)

⚠ The wall control is provided inside the package already assembled.

- 1. Base of control
- 2. Wall-mounted control panel

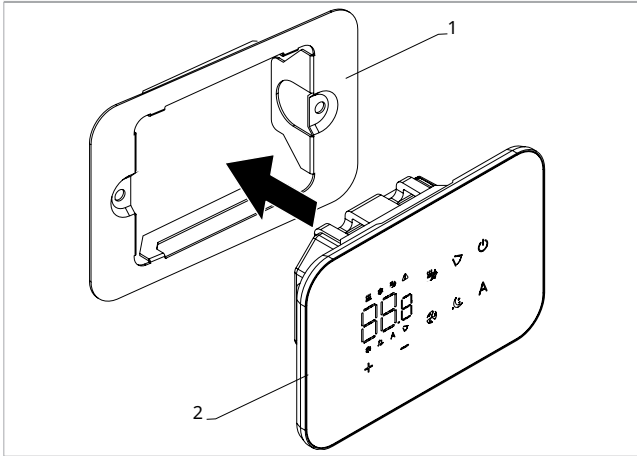

Before wall installation:

- separate the base of the control consisting of a plate from the control panel

- 1. Fixing screws
- 2. Base of control
- 3. Holes for fixing to electrical box
- 4. Electric box 503

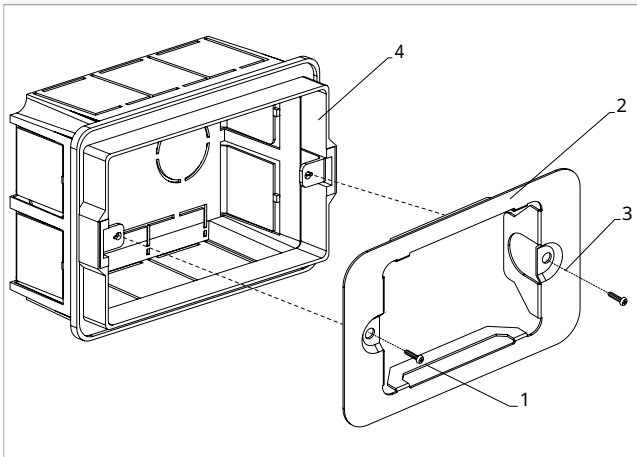

For wall mounting of the control panel:

- fix the control base to the electrical box 503 with screws
- connect the electrics

⚠ Before making the connections, please verify that the control terminal block is on the right-hand side.

- 1. Electric box 503
- 2. Base of control
- 3. Wall-mounted control panel

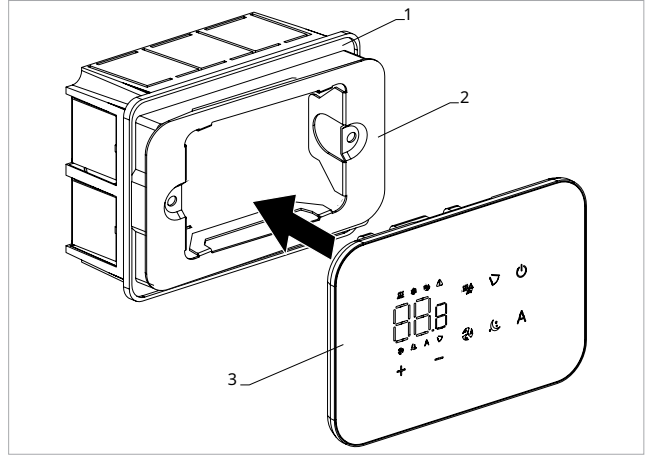

- Close the control panel

⚠ Pay attention not to crush the conductors when you close the control.

7.4 Multiple connection diagram

- | | | | |
|----|--------------------------------------|----|--------------------------------------|
| 1. | M7 series wall control panel | 3. | PCB |
| 2. | Terminal block for device connection | 4. | Board for pairing control and device |

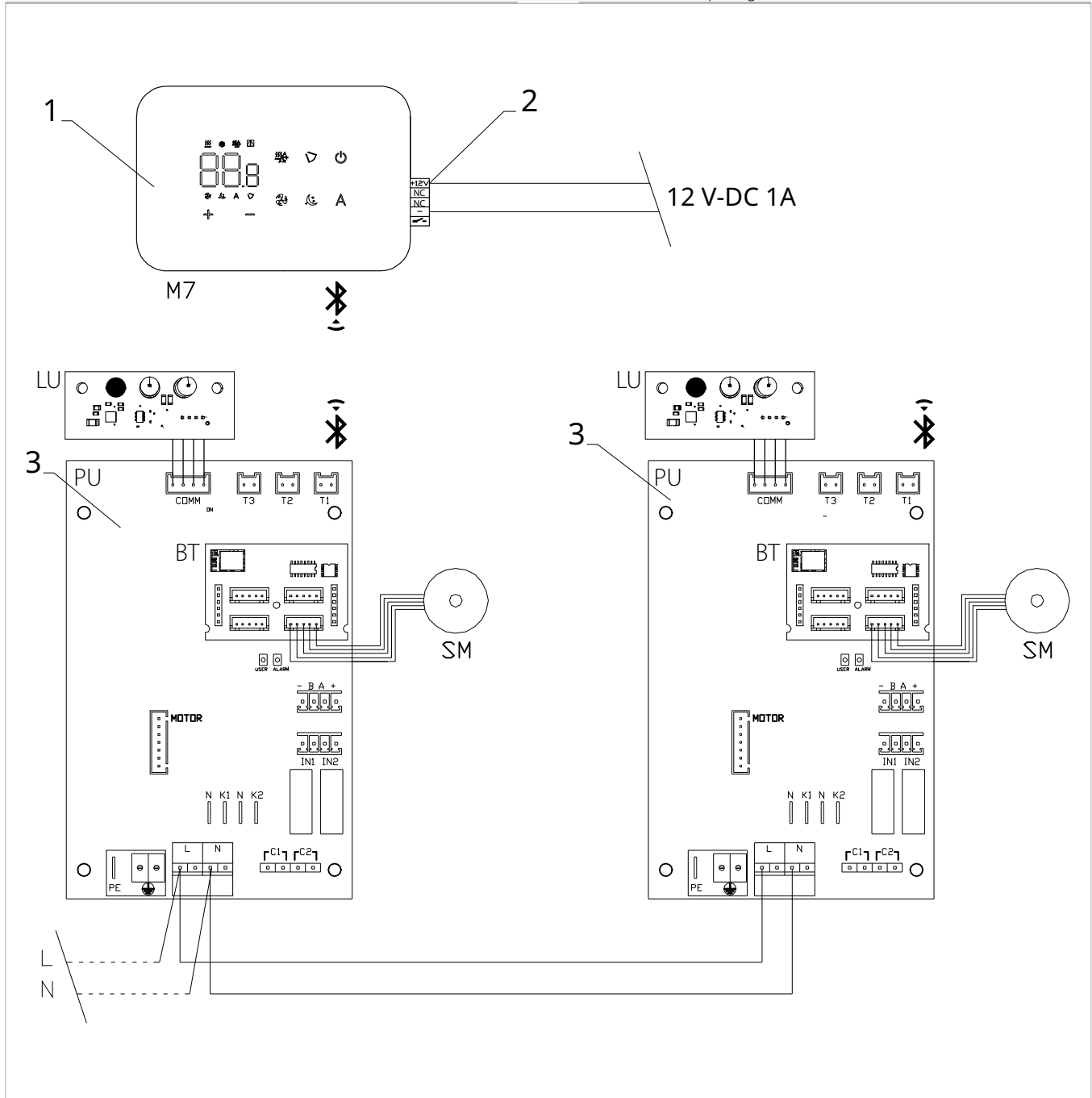

7.5 Connections

7.5.1 Preliminary warnings

- ⚠ The terminals for connecting the control panel and the presence contact CP are placed in a plastic bag and positioned inside the cover of the electrical box.

1. Terminal blocks

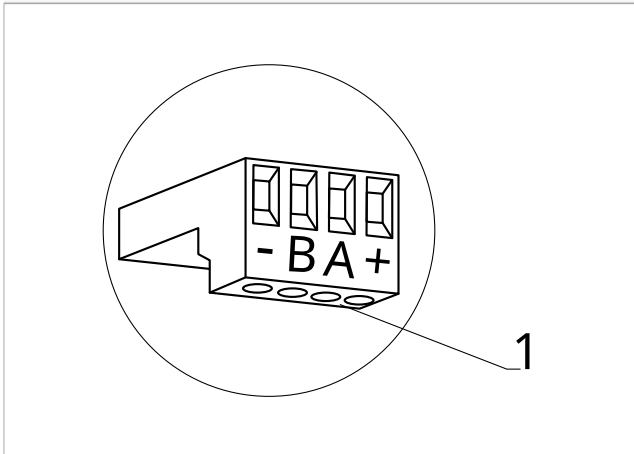

The terminals accept:

- rigid or flexible wires with a 0.2 to 1 mm² cross-section
- rigid or flexible wires with 0,5 mm² cross-section if two wires are connected to the same terminal block
- rigid or flexible wires with 0,75 mm² cross-section if the wires have wire end ferrules with a plastic collar

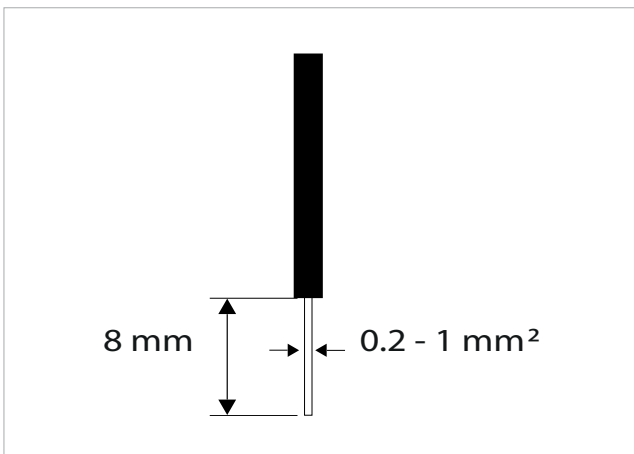

To connect the cables:

- strip the wire
- if the wire is rigid, you can insert it easily whereas
- if it is flexible, use appropriate crimp terminals
- push the wire completely in
- check the right fixing by pulling it gently

7.5.2 Control Panel

- ⚠ The control panel for wall control must be ordered separately.

Terminal block position:

1. Terminal block (Back view panel)

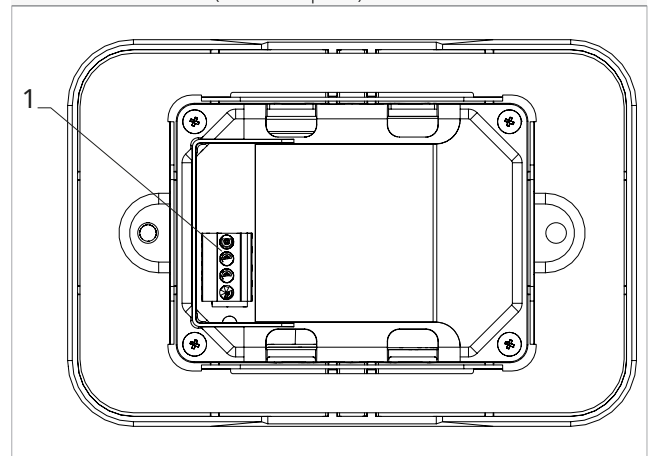

1. Terminal blocks

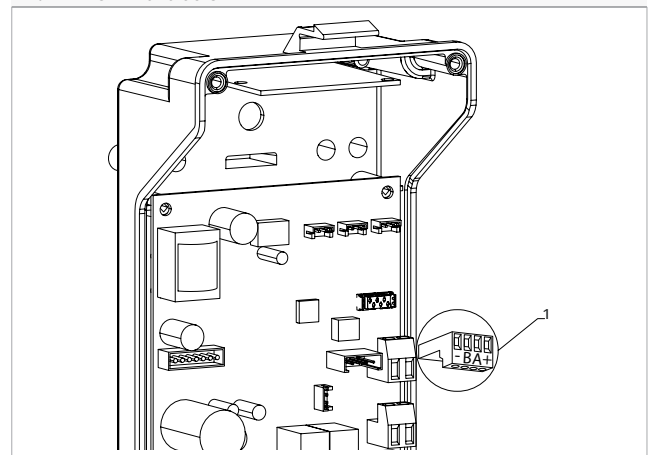

To connect the wall control panel to the board:

- connect the power supply cables to a 12 V-DC power supply

7.5.3 Presence contact CP

Trough this contact it is possible connect an external device that inhibits the operation of the device, for example:

- opening window contact
- remote on/off
- infrared presence sensor
- enabling badge
- remote change of season

Function

The contact is normally open.

- when closing the CP contact, connected to a potential-free contact, the device switches to stand-by mode

CP appears on the display.

- At the touch of a button on the display the symbol ⚠ flashes.

- ⊖ It is forbidden connect in parallel the CP input to one of another electronic board. Use separate contacts.

The CP presence contact can be configured for heating and cooling operation via the "To select digital input" [p. 45](#) settings menu item (digital input).

7.5.4 Bluetooth connection





The wall-mounted remote control can be connected via Bluetooth to one or more devices, for a maximum of 16.

The devices must be equipped with an electronic board suitable for remote control.



7.6 Functions

7.6.1 Basic menu

To access the basic menu

- with the display off, hold down  for 10 seconds
The device turns on and  appears
- keep pressed until the indication  appears
- release the  key
The symbol  appears

To navigate in the menu

- use the icons  

To select a menu item and to confirm the changes made

- press the icon 
Confirming the change takes you to the next item.

To exit the menu

- press the icon  for 10 seconds
- or wait 30 seconds the automatic shutdown

 After 30 seconds from the last action the control goes out and the settings is memorized.

Menu items

ot: AIR probe offset (air probe setting)

ur: Value read by the R.H. sensor

ut: Probe Offset PT4

uS: Humidity setpoint





ui: Humidity hysteresis

CF: Scale

ub: Buzzer volume



Set AIR probe offset

To set the air probe regulation

- press  to change settings
- increase or decrease the value with the icons  
- press  to confirm
*By default it is set to 0.
The setting range is from a minimum of -12.0 °C to a maximum of 12.0 °C.*





Scale

To change the temperature unit of measure

- select 
- press  to change settings
- select °C or °F
- press  to confirm
By default the temperature unit of measure is °C.

Adjusting buzzer volume

To change the volume





- select 
- press  to change settings
- increase or decrease the value with the icons  
- press  to confirm
The volume setting range is from 00 (min) to 03 (max).

 The volume changes after confirm the modification.

Set probe offset RH





 Modify only after real deviations from an actual measurement with professional instrumentation have been established.

To set the RH probe regulation

- select 
- press  to change settings
- increase or decrease the value with the icons  
- press  to confirm





Set the humidity setpoint

To set the humidity setpoint

- select 
- press  to change settings
- increase or decrease the value with the icons  
- press  to confirm
The setting range is from 20.0% to 90.0%.

Setting the humidity hysteresis

To set the humidity hysteresis





- select 
- press  to change settings
- increase or decrease the value with the icons  
- press  to confirm
The setting range is from 1 (min) to 30 (max).

7.6.2 Advanced Menu



 To access the Setup menu, it is necessary to access the Basic menu. See section "Basic menu" [p. 44](#).

The special functions menu can be accessed via the control panel.

To access the setup menu

- from the basic menu press **A**
Appears 
- press the  key once
Appears 
- press  to confirm and log in
This takes you to the settings menu.



To navigate in the menu

- use the icons  

To select a menu item and to confirm the changes made

- press  for 2 seconds
Confirming the change takes you to the next item.

To exit the menu

- press  for about 10 seconds
Appears 
- press  for about 10 seconds
The display turns off.
- or wait 30 seconds after the last action
The display is switched off automatically.

 After 30 seconds from the last action the control goes out and the settings is memorized.

Menu items

Ad: Not used

Pr: Not used

of: Options for digital output

rC: Radiant cooling options with R20

rH: Radiant heating options with R20

UC: Not used

Ac: Not used

Ah: Not used

Fr: Not used

Set radiant options in heating with R20

 To change the rH function, it is necessary to have the accessory MZS - Single zone module for radiant system, code EG1028II.



 To change the settings, please refer to the Instruction Sheet of the accessory MZS - Single zone module for radiant system, code EG1028II.

Set radiant options to cooling with R20



 To change the rC function, it is necessary to have the accessory MZS - Single zone module for radiant system, code EG1028II.

 To change the settings, please refer to the Instruction Sheet of the accessory MZS - Single zone module for radiant system, code EG1028II.

To select digital input**To change the digital input**

- select 
- press  to change settings
- select CP for contact presence (default)
- select CO to cooling open
- select CC to cooling close
- press  to confirm
By default digital input is set to CP.

 For return to the default settings, set the digital input to "CP".

 By selecting one of the other inputs (CO,CC) the seasonality is locked. It is not possible to modify it through the key  of the control.

Set radiant options in heating with R20

 To change the rH function, it is necessary to have the accessory MZS - Single zone module for radiant system, code EG1028II.

 To change the settings, please refer to the Instruction Sheet of the accessory MZS - Single zone module for radiant system, code EG1028II.

Set radiant options to cooling with R20

 To change the rC function, it is necessary to have the accessory MZS - Single zone module for radiant system, code EG1028II.

 To change the settings, please refer to the Instruction Sheet of the accessory MZS - Single zone module for radiant system, code EG1028II.

7.6.3 Pairing of control and unit**To pair the control with the unit**

- with control switched on, at the same time press  and **A** for about 10 seconds
*In the display area, where the setpoint is indicated, appears the number of connected devices.
The displayed value flashes.*

- 1. Red LED
- 2. Green LED
- 3. Black button
- 4. Electrical box

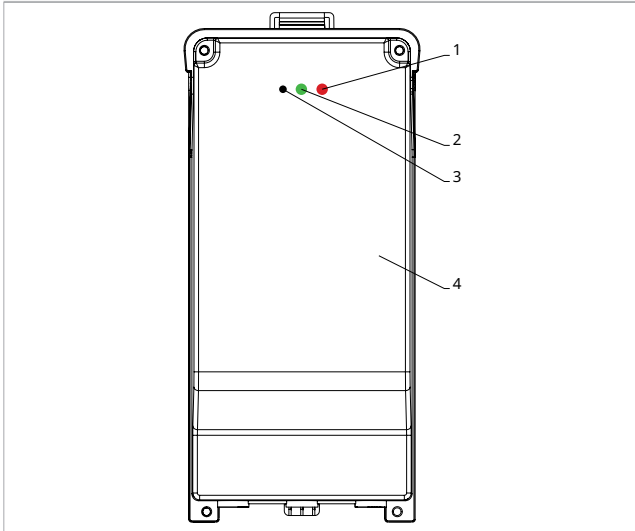

On the electrical box on the unit

- press the black button for 3 seconds
The green LED flashes.
The red LED is on.
- wait for the procedure to complete
The green LED stops flashing.

On the wall mounted control panel

- *Appear the number assigned to the fancoil.*
Then appears the number of connected devices.
- press to exit the menu

Reset pairing

⚠ To reset the pairing settings, it is first necessary to access the "Basic menu" p. 44.

To reset pairing settings

- access the basic menu
- press
- press
- *All the way to the menu.*
- press

To reset a single fancoil

- *Appears*
- press
- *Appears*
- press to access the menu
- use the icons to move inside the menu
The assignment numbers assigned to the fancoils appear.
- select the fancoil to be reset
- press to confirm
 appears, with an acoustic signal.
The device is removed.

To exit the setting

- press for 5 seconds
Exit the setting.
Back to menu 02.

To reset all fancoils

- *Appears*
- press until appears
- *Appears*
- press to access the menu
- use the icons to move inside the menu
- select No to maintain all fancoils
- select Yes to reset the fancoils
- press to confirm

LED interface operation on the electrical box

If the device is in provisioning

The green LED flashes.

If the device is provided and functioning

The green LED is on.

If the device has not been provisioned and is not functional

The green LED is off.
The red LED is on.

If the device is in alarm status

The red LED flashes.

⚠ The red LED flashes according to the type of alarm. To check the alarm type, please refer to the following "Error signals" p. 47 section.

If communication with the board is missing

The green and red LEDs will flash once every second.

7.6.4 Error signals

The PCB has a status LED.

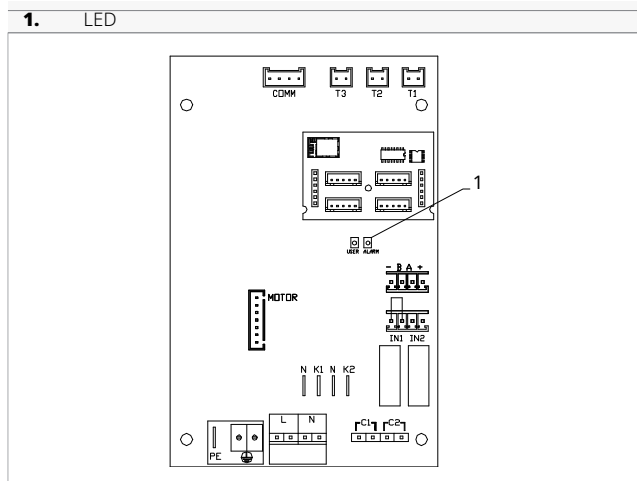

⚠ Once the pairing has been completed, the red LED on the cover of the electrical box performs the same functions as the LED on the board on the unit.

⚠ The flashing LED indicates errors.

⚠ With the LED on, it is indicated that there aren't errors.

LED signals





- Led flashing
Errors to be shown on the display.
- LED off
Remote control switched off.
- LED on
Wall control panel on and no alarm.
- LED continuous flashing with pause between flashes
Unsuitable water temperature alarm.
- LED 2 flashes / pause
Internal fan motor alarm faulty or disconnected.
- LED 3 flashes / pause
Alarm for water temperature probe H2/T2 disconnected or faulty.
- LED 6 flashes / pause
Communication error alarm with wall control panel.

7.6.5 Alarm display on wall control panel

⚠ In the event of an alarm, the device still maintains active functions.

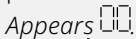
⚠ The symbol ⚠ is displayed to indicate alarms on the wall control panel.

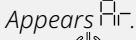
⚠ **To access the Setup menu, it is necessary to access the Basic menu. See section "Basic menu" p. 44.**

- access the basic menu
- press 
Appears .
- press 
Appears .
- press 
Then the number assigned to the fancoil appears and then the error is displayed.

Alarms displayed on the wall control panel

- E2 Faulty internal fan motor or disconnected
None of the modes can be activated.
- E3 Water temperature probe H2/T2 disconnected or failure
None of the modes can be activated.
- E6 Fancoil block for unsuitable water
None of the modes can be activated.
- E7 Module Communication Alarm
Bluetooth communication not functioning.
- E8 Communication error
Error in the communication between the wall control panel and the fancoil. None of the unit's functions can be activated.
- h2o Incorrect water temperature
*In heating mode, the water temperature is below 30 °C.
In cooling mode, the water temperature is above 20 °C.*

⚠ Errors E7 and E8 are displayed without the error display procedure on the wall control panel.

⚠ Alarm E7 is an error that only appears with the control panel for wall control with Bluetooth connection (Code EGB749II).

REMOTE CONTROL EEA649 - EEB649 / EFA649 - EFB649

8.1 Interface

- 1. Display area
- 2. Keys area

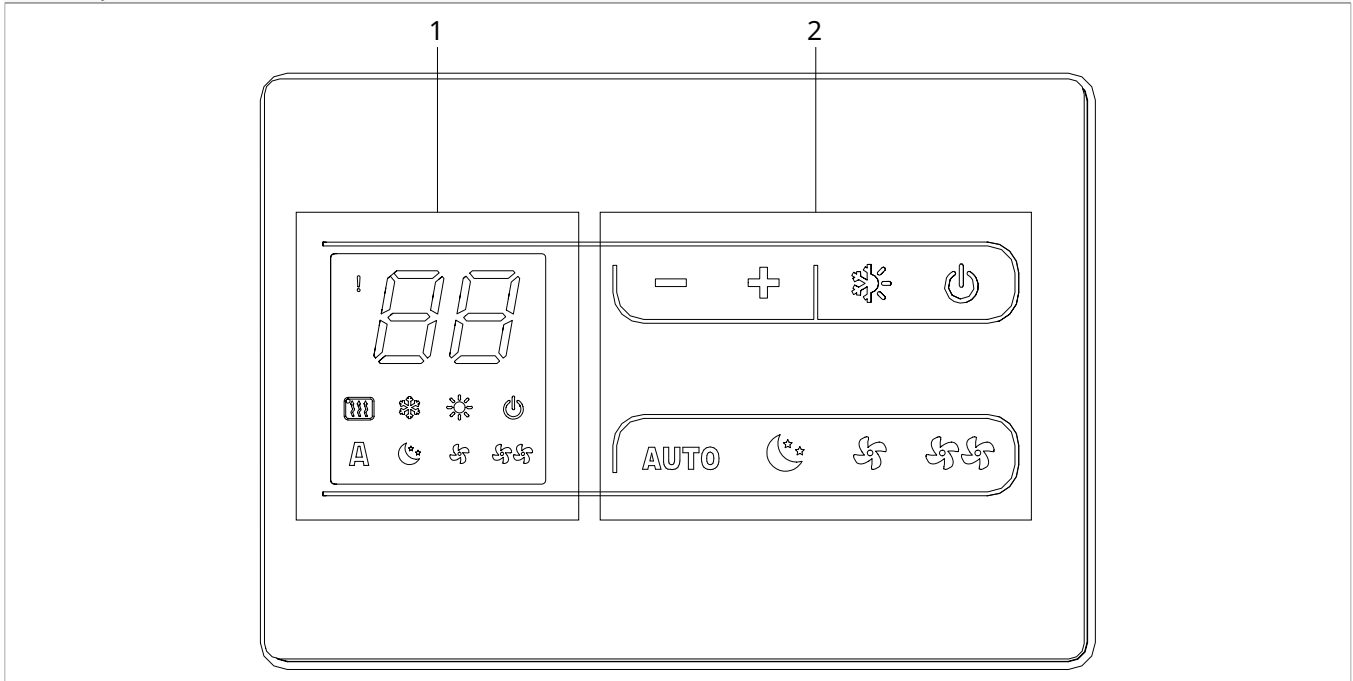

8.2 Installation

8.2.1 Description

The wall-mounted control panel is a thermostat with possibility of control on several device equipped with electronic control for remotization.

- ⚠ The control can control up to a maximum of 30 units.
- ⚠ The temperature probe can be remotized in one of the connected device.

8.2.2 Mounting

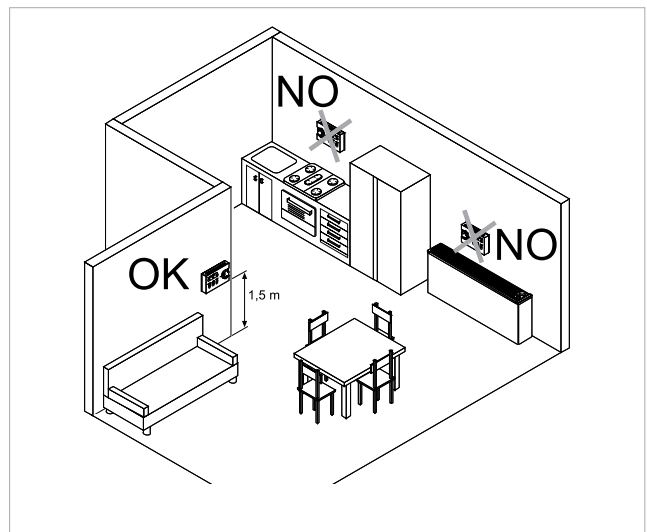

The wall control must be installed:

- on internal walls
- at a height of about 1,5 m from the floor

- away from doors or windows
- away from heat sources (heaters, convectors, stoves, direct sunlight)

⚠ The wall-mounted remote control is provided inside the package already assembled.

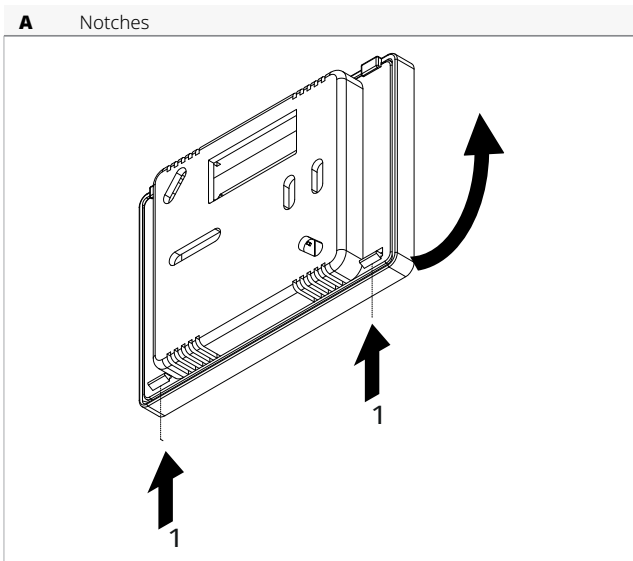

Before wall installation:

- Unhook the protruding notches on the back side of the control.
- separate the base from the control
- use the base of the control to trace the fixing point on the wall

A	Base of control
B	Holes for the wall mounting
C	Screws
D	Hole for the passage of the electrical connections

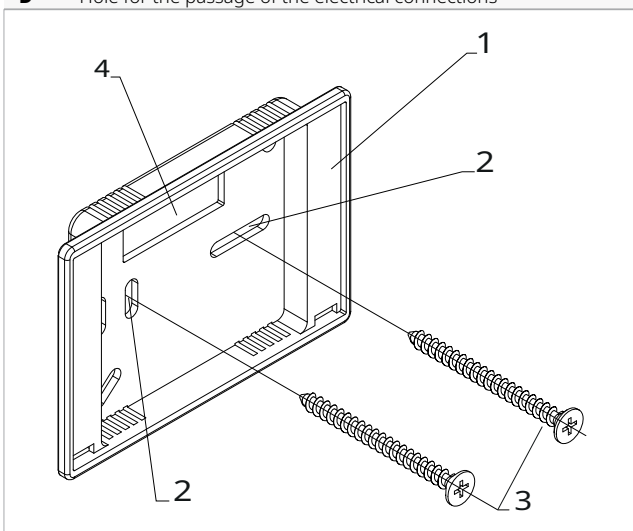

For the remote control wall mounting:

- drill holes in the wall
- pull the electric wires through the hole provided
- fix the base of the control to the wall using suitable screw and plugs
- connect the electrics
- close the control

⚠ Pay attention not to crush the conductors when you close the control.

8.3 Single connection diagram

The PCB is included in the supply.

M1	Fan motor DC Inverter
SM	Step Motor
-BA+	Serial connection for wall-mounted remote control
PE	Earth connection
L-N	Power supply connection 230 V / 50 Hz / 1 A
Y1	Water electrovalve (voltage output 230 V / 50 Hz / 1 A)
CH/C1	Cooling request contact (for example chiller or reversible heat pump). Activated in parallel with the solenoid valve output (Y1) with 1 minute delay when the fancoil is in cooling mode and is on call (potential-free contact max. 1 A).

BO/C2	Heating request contact (for example boiler or heat pump). Activated in parallel with the output of the solenoid valve (Y1) with 1 minute delay when the fancoil is in heating mode and is on call (potential-free contact max. 1 A).
H2/T2	Water temperature probe
CP	Presence contact (normally open)
PU	Electronic board on the unit
PSM	Electronic board for step motor connection

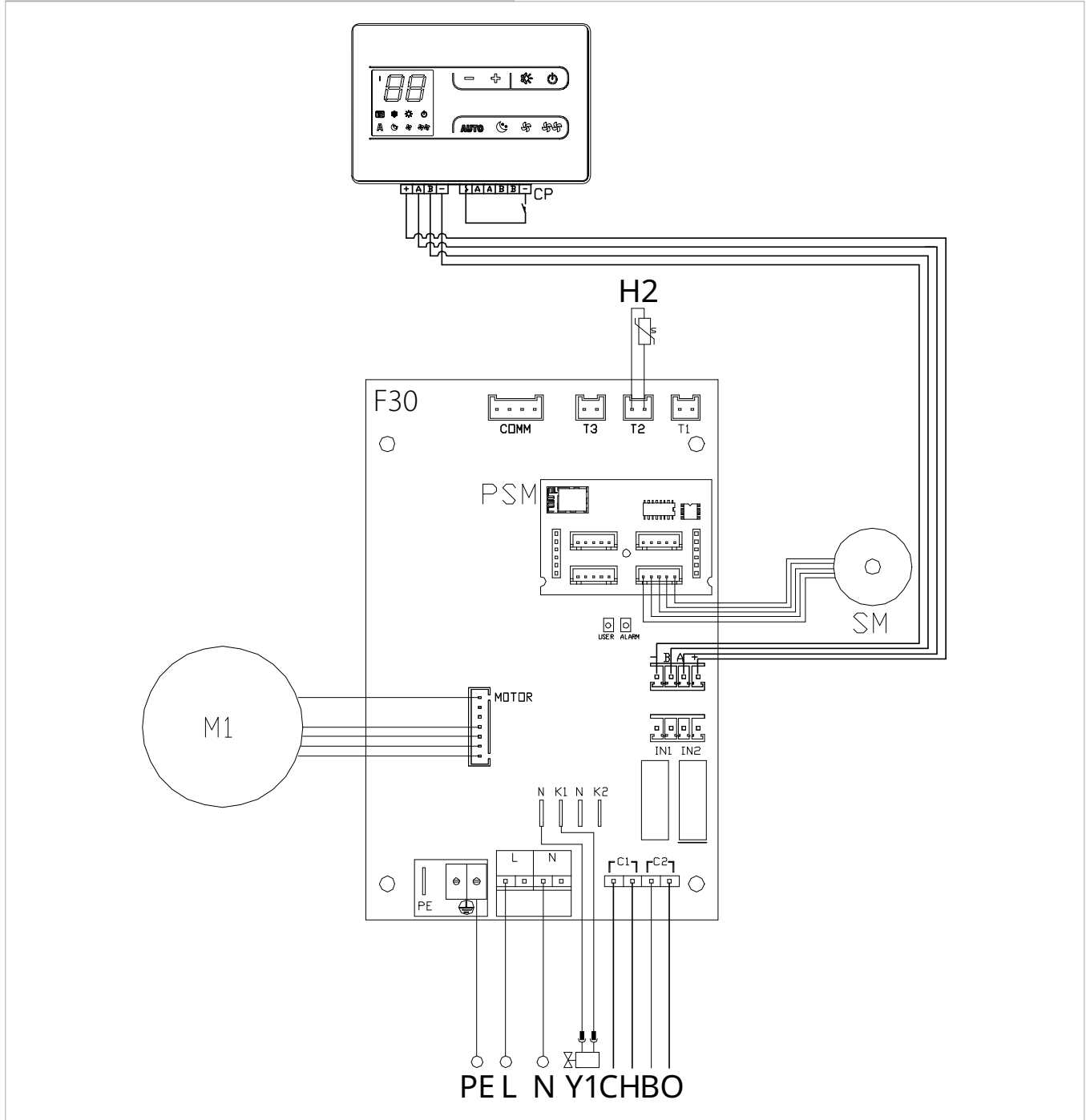

⚠ In the case of a single generator for heating and cooling (for example heat pump), simply connect the two contacts C1 and C2 in parallel and lead 2 wires to the generator.

8.4 Multiple connection diagram

- | | | | |
|----|--------------------------------------|----|---|
| 1. | Control panel for wall control | 3. | The terminal block for CP presence contact connection |
| 2. | Terminal block for device connection | 4. | PCB |

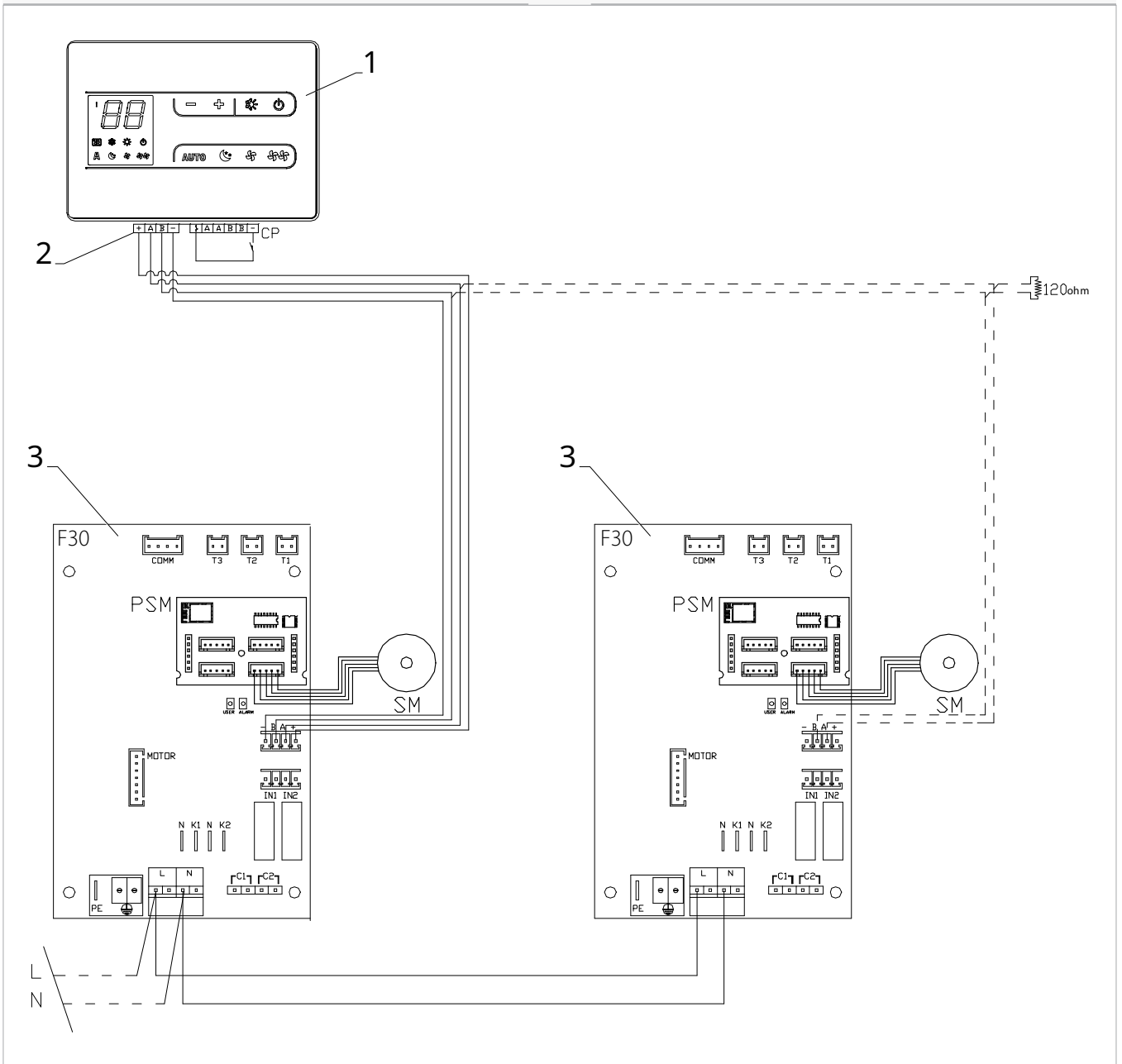

8.5 Connections

8.5.1 Preliminary warnings

- ⚠ The terminals for connecting the control panel and the presence contact CP are placed in a plastic bag and positioned inside the cover of the electrical box.

1. Terminal blocks

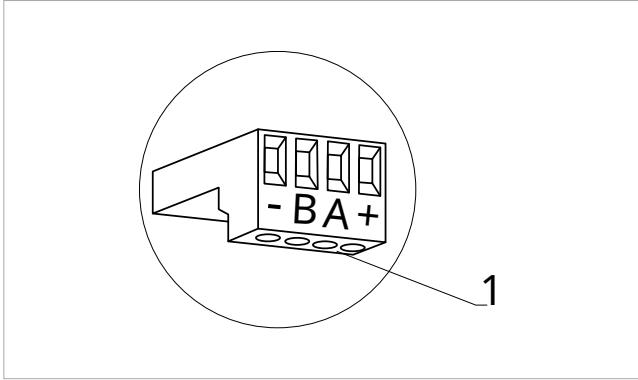

The terminals accept:

- rigid or flexible wires with a 0.2 to 1 mm² cross-section
- rigid or flexible wires with 0,5 mm² cross-section if two wires are connected to the same terminal block
- rigid or flexible wires with 0,75 mm² cross-section If the wires have wire end ferrules with a plastic collar

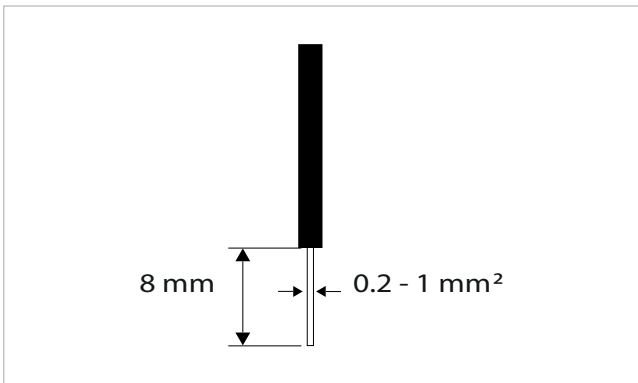

To connect the cables:

- strip 8 mm of the wire
- if the wire is rigid, you can insert it easily whereas
- if it is flexible, use appropriate crimp terminals
- push the wire completely in
- check the right fixing by pulling it gently

8.5.2 Control Panel

⚠ The control panel for wall control must be ordered separately.

Terminal block position:

1. Terminal blocks

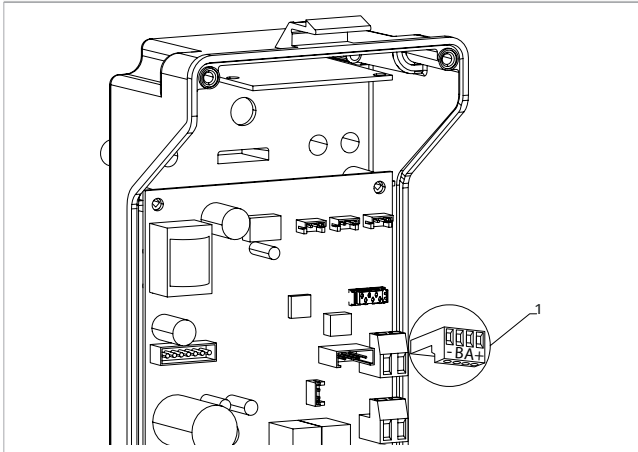

To connect the wall control panel to the board:

- connect the power supply cables to the + - terminals
- connect the ModBus serial connection cables to terminals A and B

8.5.3 Presence contact CP

Trough this contact it is possible connect an external device that inhibits the operation of the device, for example:

- opening window contact
- remote on/off
- infrared presence sensor
- enabling badge
- remote change of season

Function

The contact is normally open.

- when closing the CP contact, connected to a potential-free contact, the device switches to stand-by mode
- CP appears on the display.*
- At the touch of a button on the display the symbol ⚠ flashes.

⊖ It is forbidden connect in parallel the CP input to one of another electronic board. Use separate contacts.

The CP presence contact can be configured for heating and cooling operation via the "Select Digital Input" [p. 54](#) settings menu item (digital input).

8.5.4 RS485 Serial Connection

The wall-mounted remote control can be connected through a RS485 serial line to one or more device, for a maximum of 30.

The devices must be equipped with an electronic board suitable for remote control.

For the connection:

- follow the indication on the connection diagram
- connect respecting the indication "A" and "B"

⚠ Use a bipolar shielded cable suitable for the RS485 serial connection with a minimum section of 0,35 mm².

⚠ Keeping the bipolar cable separate from power supply cables.

⚠ Chase out the wall in order to minimize the length of the leads.

⚠ Complete the line with the 120 Ω resistance.

⊖ It is forbidden make star connections.

8.5.5 Set-up of auxiliary dip-switch functions

⚠ There are two dip-switches on the control circuit board for configuring the operation of the device as required.

Dip-switch B

- changes ventilation in cooling mode
- in the ON position, continuous ventilation at minimum speed is enabled even after the setpoint has been reached to allow more regular operation of the temperature probe and avoid air stratification
- in OFF position, ventilation takes place cyclically, 4 min ON - 10 min OFF

Dip-switch C

- changes the logic of night-time operation in heating mode
- in the ON position, ventilation is inhibited, allowing the appliance to heat rooms by radiation and natural convection as in traditional radiators
- in OFF position the fan operates normally

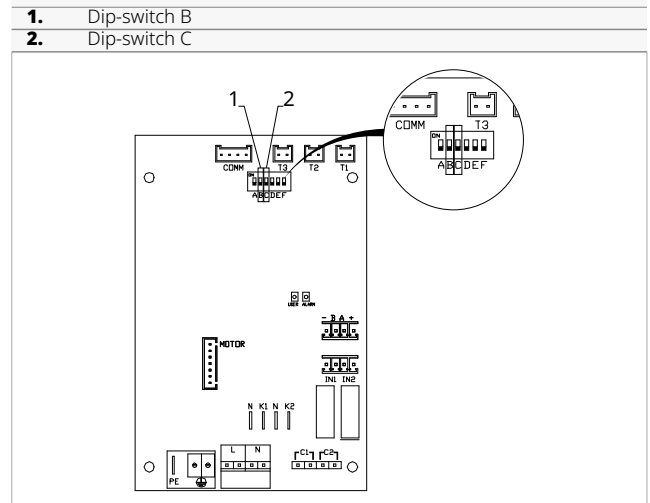



8.6 Functions



8.6.1 Advanced Menu

Through the control it is possible to access the setup menu.

To access the setup menu

- with the display off, hold down  for 10 seconds
The device turns on and the temperature appears.
- keep pressed until the indication  appears

To navigate in the menu

- use the icons  

To select a menu item and to confirm the changes made

- press the key  for about 2 seconds
During the modification the symbol flashes to remind you that you are in the setup menu.
Confirming the change takes you to the next item.

To exit the menu

- press the icon  for 10 seconds
- or wait 30 seconds the automatic shutdown

 After 30 seconds from the last action the control goes out and the settings is memorized.

Menu items

Ad: Modbus address

uu: Wifi

ub: Adjust buzzer volume

br: Adjust the brightness

di: Digital input

UC: Not used

rH: Not used

rC: Not used

hb: Not used

Ab: Not used

rb: Reset Modbus

Fr: Not used

ot: Not used



oh: Not used

Sc: Not used

rE: Not used

Set the modbus address

To set the Modbus address

- select 
 - increase or decrease the value with the icons  
- The setting range is from 01 (min) to 99 (max).*

Enable or disable Wifi



To enable or disable Wifi

- select 
 - select "YS" to enable wifi
 - select "rs" to reset the settings
 - select "no" to disable wifi
- By default wifi is enabled.*

 This function can only be used for controls with integrated WiFi (EFA649 - EFB649).

Adjusting buzzer volume



To change the volume

- select 
 - increase or decrease the value with the icons  
- The volume setting range is from 00 (min) to 03 (max).*



 The volume changes after confirm the modification.

Adjust the brightness of the display

To adjust the brightness of the display

- select 
 - increase or decrease the value with the icons  
- The brightness setting range is from 00 to 01.

 The display brightness changes after confirm the modification.



 You can also reduce the brightness of the display through the keys of the control. With the display off, hold down  for about 20 seconds, the message "01" will appear. Press  to decrease the brightness to "00". Wait 30 seconds for the correct setting to be checked.

Select Digital Input

To change digital input

- select 
 - select CP for potential-free contact (default)
 - select CO to cooling open
 - select CC to cooling close
- By default digital input is set to CP.

 For return to the default settings, set the digital input to "CP".

 By selecting one of the other inputs (CO,CC) the seasonality is locked. It is not possible to modify it through the key  of the control.

Reset Modbus

- select 
- select "no" to keep the current settings
- select "YS" to reset the settings

8.6.2 Long period shut-down

For seasonal shutdowns or for long periods:

- disable the device
- set the main system switch to Off

 The antifreeze function is not on.

8.6.3 LED signals

1. LED

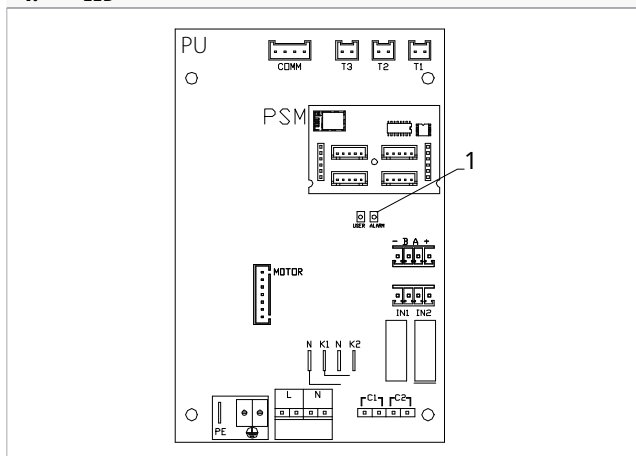

The PCB has a status LED.

LED signals

- LED off
Device switched off or without power supply.

- LED on
Normal operating of the device
- LED 1 flash / pause
Water request detected by temperature probe H2/T2 not fulfilled (above 20 °C in cooling and below 30 °C in heating). It causes the fan to stop until the temperature reaches a value suitable to satisfy the request. (*)
- LED 2 flashes / pause
Motor alarm (for example jamming due to foreign bodies or fault in the rotation sensor).
- LED 3 flashes / pause
H2/T2 water temperature probe disconnected or faulty. Verify that the installed probe is 10 kΩ.
- LED 6 flashes / pause
Communication error caused by lack of continuous information exchange on the serial line. If the exchange of information lasts for more than 5 minutes, the error is displayed.

1. * In case of a operation without water probe H2/T2, the fan stop thresholds will be ignored.

8.6.4 Alarm display on wall control panel

 In the event of an alarm, the device still maintains active functions.

- E1 Room temperature probe disconnected or faulty
None of the modes can be activated.
- E2 Fault or connection of a remote double room sensor on one of the fan coil units
None of the modes can be activated.
- E3 Humidity probe disconnected or faulty
None of the modes can be activated.
- E4 Air quality probe disconnected or faulty
None of the modes can be activated.

FIXED SPEED REMOTE CONTROLS CODE B3V151

9.1 Interface

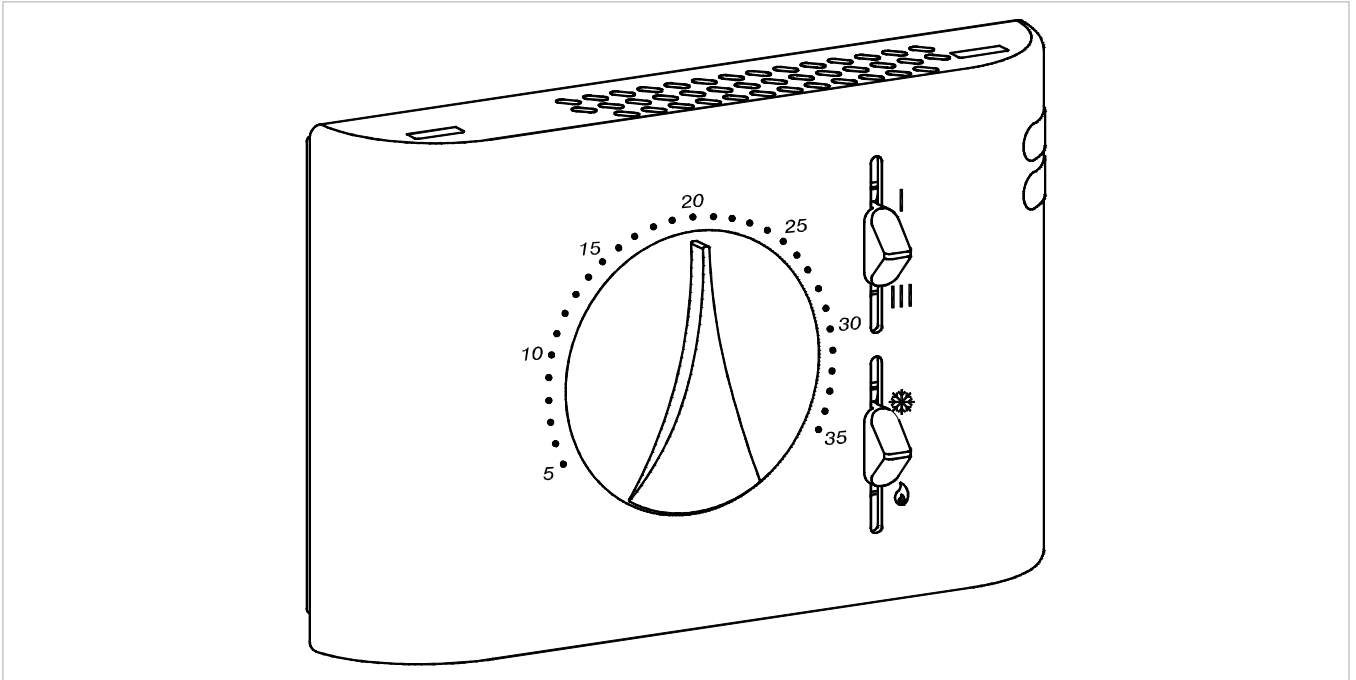

9.2 Description

Wall mounted control with thermostat, summer/winter and speed selectors.

9.3 Connection diagram

Board B3V151

1. PCB
2. Wall control

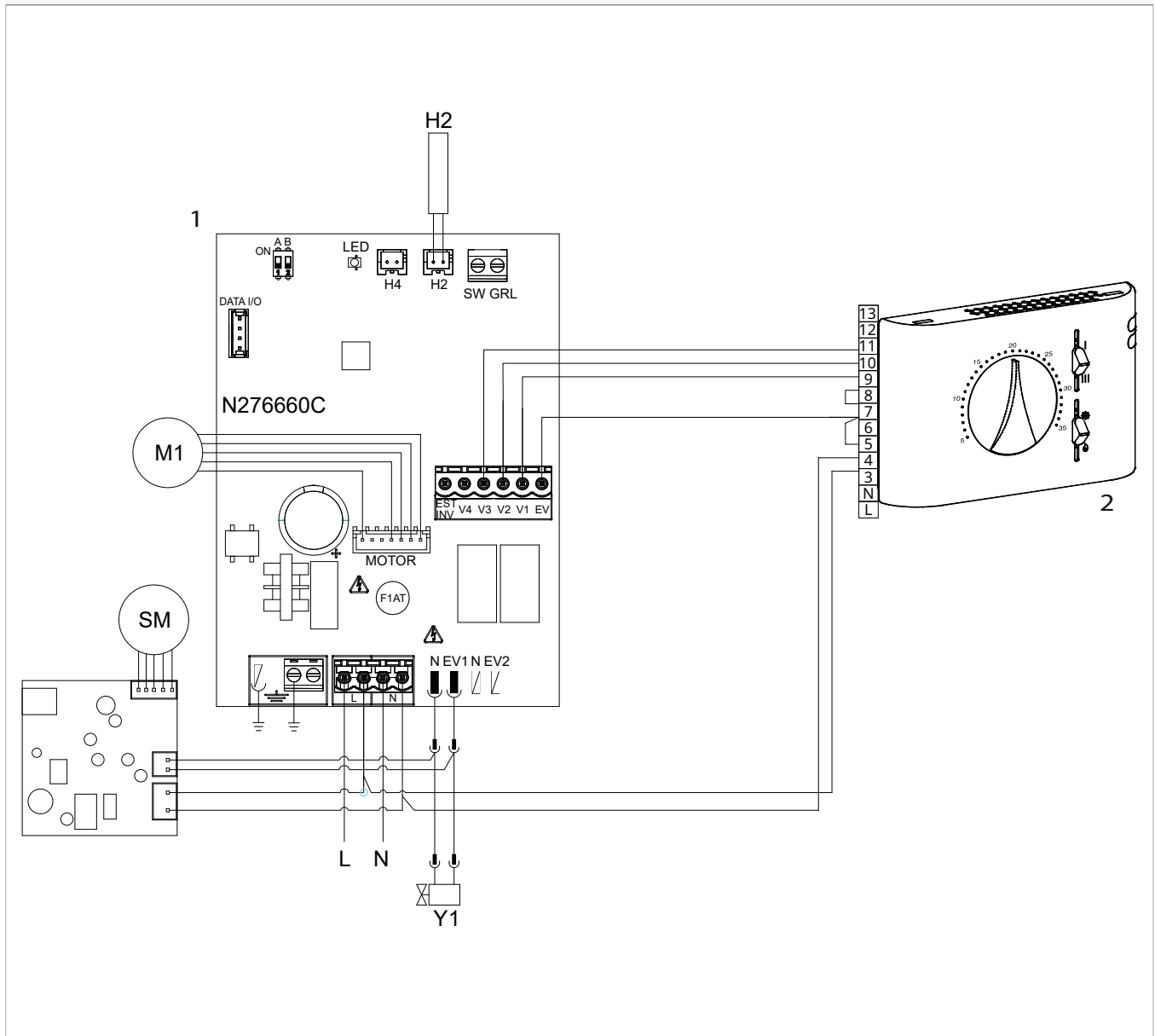

9.4 Connection diagram with seasonal switching

L-N	230 V / 50 Hz power supply
EV	Consent input
V1	Maximum fan speed (1400 rpm)
V2	Medium fan speed (1100 rpm)
V3	Minimum fan speed (680 rpm)
V4	Super-silent speed (400 rpm)
Y1	Water electrovalve (voltage output 230 V / 50 Hz / 1 A)

Y2	Mobile aspiration panel control (230 V / 50 Hz / 1 A voltage output)
RS	RS version wiring
HRS	RS water probe (10 kΩ)
M1	Fan motor DC Inverter
KE	Auxiliary relay (not included in supply)

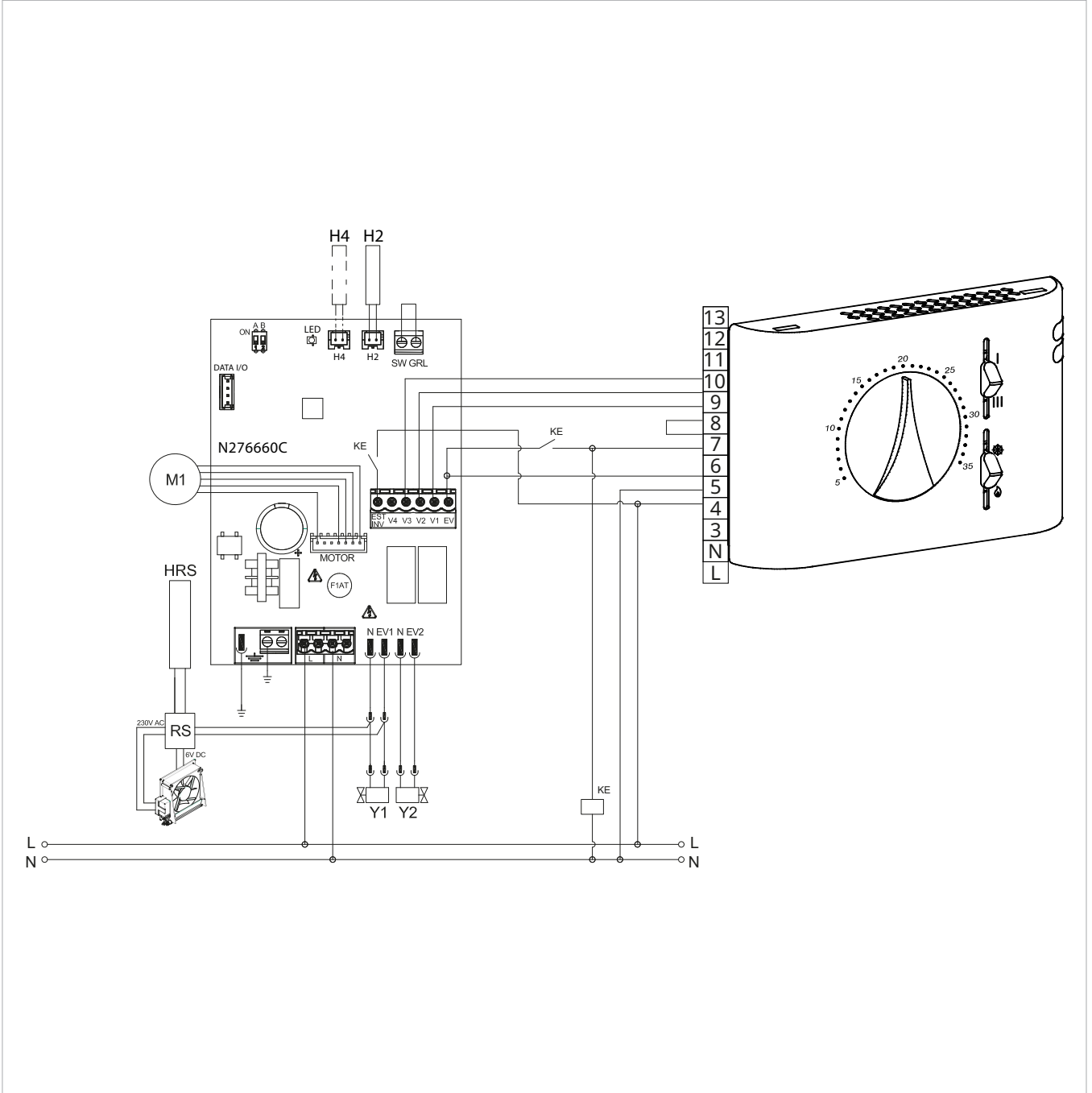

9.5 Generic thermostat connection diagram

The PCB is included in the supply.

N-L	230 V/50 Hz electrical power supply
EV	Solenoid valve permission input
V1	Maximum fan speed 1.400 rpm
V2	Medium fan speed 1.100 rpm
V3	Minimum fan speed 680 rpm
V4	Super-silent speed 400 rpm
E	Heating, cooling selection input
Y1	Water solenoid valve (230 V/50 Hz 1 A power output)

M1	Fan motor DC Inverter
SM	Step motor (diffuser)
TA	3 speed room thermostat (to buy, install and connect by the installer)
CV	Thermostat consent
SV	Speed selector
H2*	Water temperature probe 10 kΩ
*	Located in the battery on the unit.

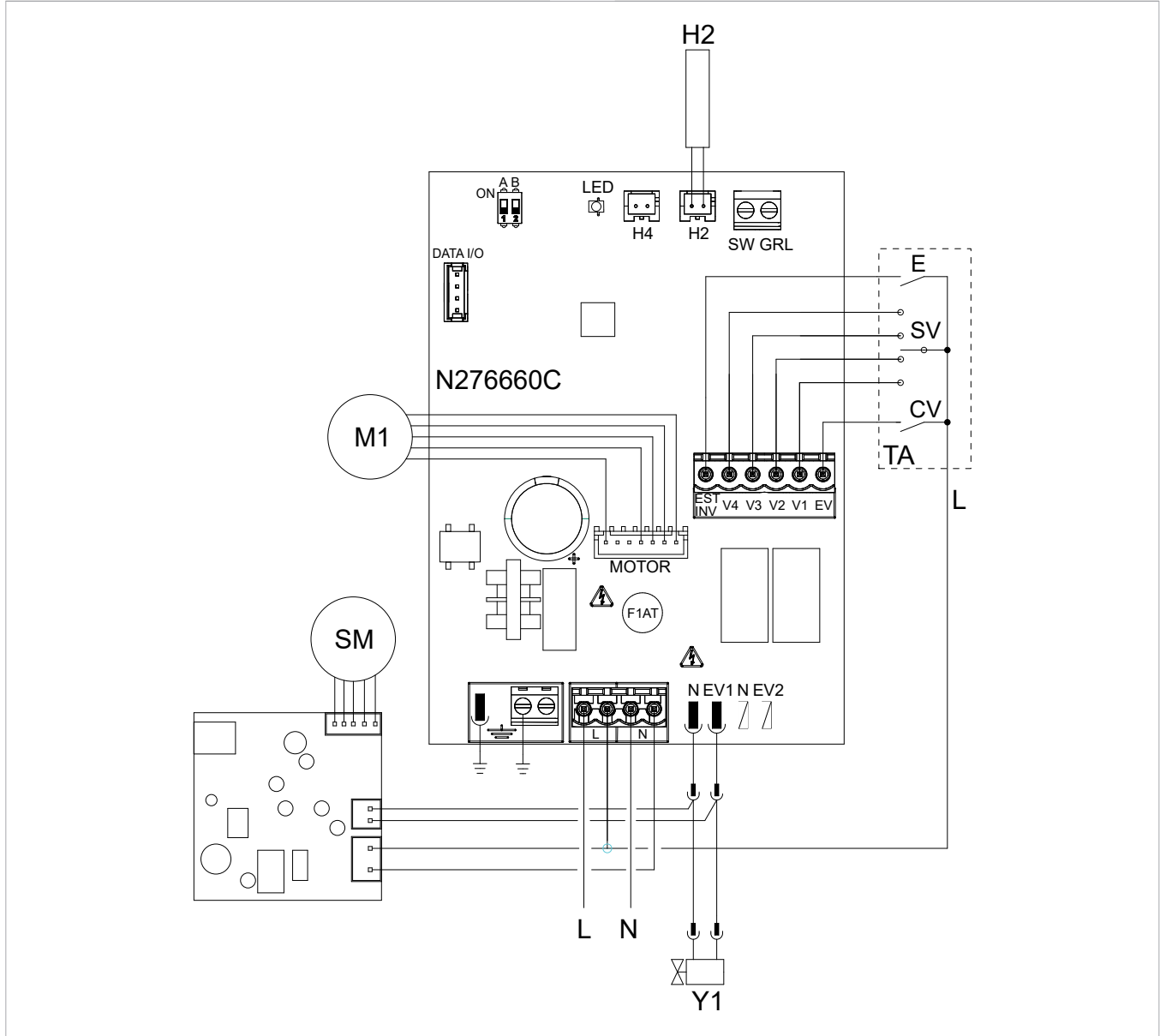

9.6 Connections

9.6.1 Connection with 3 speed thermostats

CV input

The CV input is the ON/OFF of the board.

- in case of open input, the circuit board goes into stand-by mode
- in case of closed input, the circuit board is in operation

⚠ Please refer to the sections of the electrical diagrams for connection indications.

To activate solenoid valve Y1

- Connect the CV input to the terminal L of the 230 V power supply

Speed inputs V1, V2, V3, V4

Inputs V1, V2, V3, V4 regulate the ventilation speed.

The printed circuit board has 4 speed inputs:

- V1 maximum speed (1500 rpm)
- V2 - medium speed (1100 rpm)
- V3 - minimum speed (680 rpm)
- V4 supersilent speed (550 rpm)

⚠ Connect the 3 speeds of the thermostat to three of the four available inputs based on the characteristics and use of the location.

Examples:

- to residential application where maximum silence is required, connect V2, V3 e V4
- for a residential application where heating capacity is a priority, connect V1, V2, V3

In the event of simultaneous closure of several inputs, the motor will run at a number of revolutions equal to that set by the connection with the highest speed.

⚠ You can connect several boards in parallel to a single thermostat, even using different speed.

9.6.2 Water probe management

Through the water temperature probe (10 kΩ) positioned in the compartment on the unit's coil, the functions can be regulated:

- minimum temperature in heating mode (30 °C)
- maximum temperature in cooling mode (20 °C)

Water probe connection to the control

In case of combination with electromechanical thermostats, or other commercial controls

- the H2 water probe must not be connected to the circuit board on the appliance

The printed circuit board works in:

- minimum water temperature for heating function (<30 °C)
- maximum water temperature for cooling function (>20 °C)

⚠ If the printed circuit board detects the water temperature probe correctly, start-up takes place under normal conditions.

In case of temperature not suitable for active operation:

- the ventilation stops
- error is indicated by the flashing of the LED on the PCB

Operating mode Heating/cooling

The Heating/Cooling operation mode is activated through the EST-INV input on the printed circuit board:

- when the connection is open, heating operation is activated
- when the connection is closed, Cooling operation is activated

⚠ It is possible to use the device without the water probe activated. In this case the error is signaled on led.

⚠ Please refer to "Error signals" for LED indications.

To confirm operation without probe

- disconnect and connect the board power
This condition will be saved by the board for all subsequent starts.
- reconnect the probe to resume normal operation

9.7 Error signals

LED signals

- LED off
The CV contact is open, stand-by condition.
- LED on
The CV contact is closed, normal operation.
- LED 1 flash / pause
Water temperature probe H2 alarm not suitable, temporary stop of the ventilation until the temperature reaches an appropriate value.
- LED 2 flashes / pause
Motor alarm (for example jamming due to foreign bodies or fault in the rotation sensor).
- LED 3 flashes / pause
Water probe alarm disconnected or faulty.

0-10 V CONNECTION

10.1 Connection diagram

The PCB is included in the supply.

M1	Fan motor DC Inverter	Y1	Water electrovalve (voltage output 230 V / 50 Hz / 1 A)
SM	Step Motor	10V	Input 0-10 V
PE	Earth connection	F10	Electronic board on the machine
L-N	Power supply connection 230 V / 50 Hz / 1 A	PMS	Electrical board for step motor connection

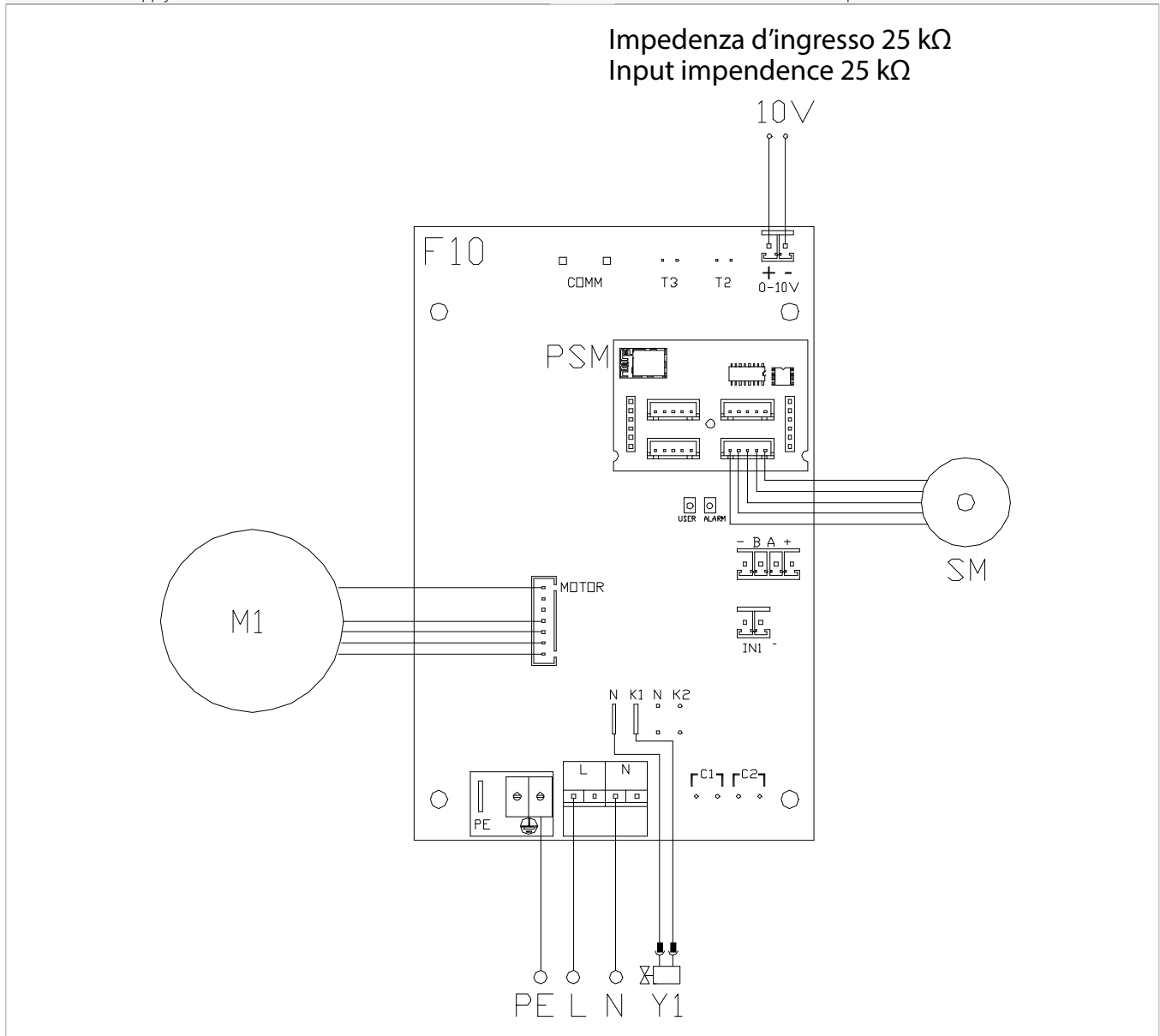

10.2 Connections

The 10 V input activates the Y1 electrovalve and regulates the fan speed.

The speed range provides a linear adjustment from the minimum value (400 rpm) to the maximum value (1500 rpm) for voltage values $\geq 1,1 \text{ V} \div 10 \text{ V DC}$.

The solenoid valve Y1:

- is enabled by voltage values $> 1 \text{ V DC}$
- turns off with values $< 0,9 \text{ V DC}$

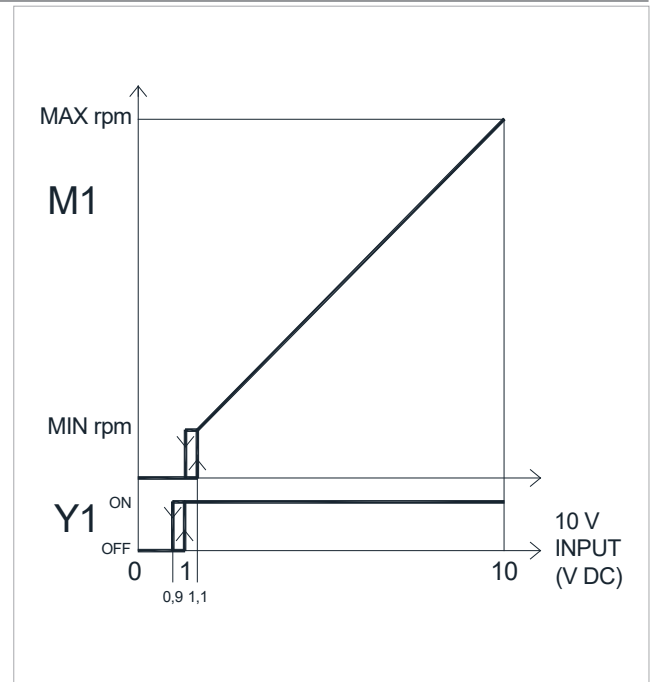

10.3 Error signals

LED signals

- LED off
The input signal is less than 0.9 V.
- LED on
Normal operation, the input signal is greater than 1 V.
- LED 2 flashes / pause
Motor alarm (for example jamming due to foreign bodies or fault in the rotation sensor).

MAINTENANCE

Routine maintenance is essential to keep the device always efficient, safe and reliable over time.

11.1 Preliminary warnings

⚠ This section is dedicated to the Technical Service Assistance. The features of the Technical Service Assistance are described in chapter "Recipients" p. 8.

Before each cleaning and maintenance intervention:

- disconnect the device from the power mains by turning the system master switch to OFF
- wait for the components to cool down in order to avoid any burns

⊖ Carrying out any technical or cleaning work before disconnecting the unit from the power supply is forbidden.

⚠ Make sure that there is no voltage before operating.

⚠ After completing the maintenance work, must be restored the original condition.

⚠ Warnings:

- Do not lean or sit on the fancoil to avoid damaging the appliance.
- Do not manually move the horizontal louver of the air outlet. Always use the remote control to do this operation.
- If water leaks from the device, you must switch it off immediately and disconnect the power supply. Then, call the nearest customer service centre.
- The device must not be installed in rooms where there are explosive gases or where there are conditions of humidity and temperature out of the limits defined in the installation manual.
- Clean the filter regularly.

11.2 Routine maintenance

Routine maintenance is essential to keep the device always efficient, safe and reliable over time.

Carry out cleaning:

- every six months

Before each cleaning and maintenance intervention:

- disconnect the device from the power mains by turning the system master switch to "OFF"

⚠ Wait for the components to cool down in order to avoid any burns.

⚠ After completing the maintenance work, must be restored the original condition.

⊖ It is forbidden to open the access doors and carry out any technical or cleaning intervention, before having disconnect the device from the mains supply by placing the main switch of the system on "OFF".

11.3 External cleaning

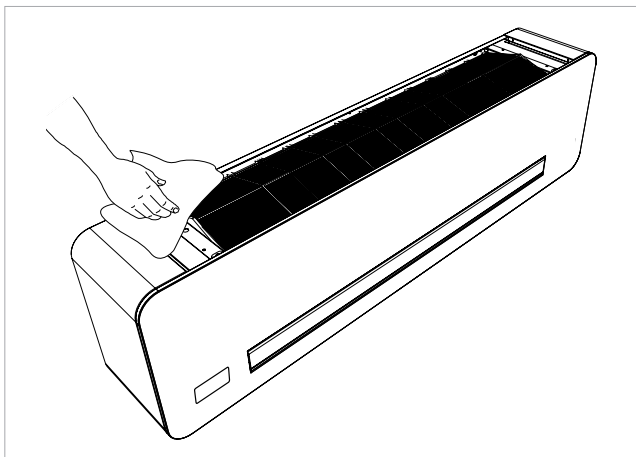

Clean the external surfaces using a soft cloth dampened with water.

⚠ Do not use abrasive sponges or abrasive or corrosive detergents as you might damage the painted surface.

⚠ Disconnect the unit from the power supply before each cleaning and maintenance intervention by setting the main power supply switch to off.

11.4 Air intake filter cleaning

Cleaning the filter must be carried out:

- after prolonged operation, considered the concentration of impurities in the air
- when you plan to restart the system after prolonged disuse

To extract the filter:

- lift it slightly

- rotate until the complete exit from the housing
- remove the filter

To clean the filters:

- use a vacuum cleaner
- aspirate dust
- wash the filter with running water
- allow it dry

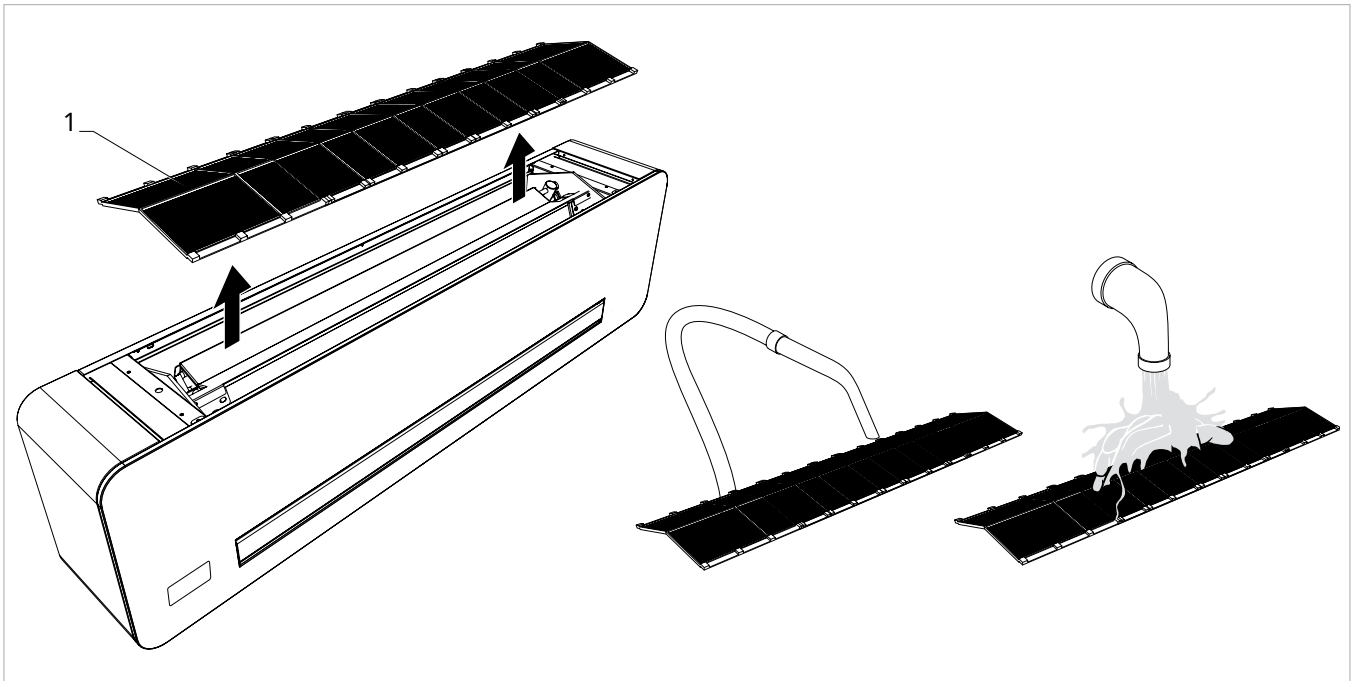

11.4.1 Inserting the filter

Remount the filter paying particular attention to introduce the lower flap in its housing.

- ⚠ After filter cleaning check if the panel is properly mounted.

- ⚠ The device features a safety switch that prevents the fan from starting if the mobile panel is incorrectly mounted or the filter are missing.

- ⊘ It is forbidden to use the device without its mesh filter.

11.5 Suggestions for energy saving

For a correct operation of the device and a great energy saving:

- keep the filters clean
- keep the doors and windows of the locations fitted with air conditioning systems closed as much as possible
- During summer limit the entry of direct sun rays into the rooms to be air-conditioned by means of external screens (projections, curtains, shutters, etc.)

TROUBLESHOOTING

12.1 Preliminary warnings

⚠ For detailed information on accessories please refer to the "Configuration accessories" p. 65 section.

Should you encounter any of the anomalies below:

- the ventilation does not start even if the water circuit is filled with hot or cold water
- the device is losing water in heating mode
- the device is losing water in cooling mode
- the device generates excessive noise
- there is dew on the front panel

Follow the instructions below:

- disconnect the device from power supply immediately
- close the water taps
- contact immediately an authorized technical support center or qualified staff

⚠ The interventions must be carried out by a qualified installer or by a specialized support center.

⊖ Do not intervene personally.

12.2 Troubleshooting table

Effect	Cause	Solution
The ventilation is delayed with respect to the new temperature or function settings.	The circuit valve requires a certain time to open and therefore to make the hot or cold water circulate inside the device.	Wait 2 or 3 minutes to allow the circuit valve to open.
The device does not activate the ventilation.	Cold or hot water is missing from the system.	Make sure the boiler or the water cooler are on.
The ventilation does not start even if the water circuit is filled with hot or cold water.	The hydraulic valve stays closed.	Demount the body of the valve and check if the water circulation is restored. Check the valve operation feeding it separately to 230 V. If you were to turn on, the problem may be in the electronic control.
	The ventilation motor is jammed or burnt.	Check the motor windings and check if the fan rotates freely.
	The wirings are not correct.	Check the electrical connections.
The device is losing water in heating mode.	Leaks at the hydraulic connections of the system.	Check the leak and tighten the connection.
	Losses in the valve group.	Check the condition of the gaskets.
There is dew on the front panel.	Detached thermal insulation.	Check the correct positioning of the thermal and acoustic insulations paying particular attention to the front one located on top of the finned coil.
There are water drops on the air vent.	High humidity conditions (>60%) might generate condensation, especially at minimum ventilation speeds.	As soon as the level of relative humidity drops, the phenomena disappears. However, a few water drops falling inside the device will not cause any malfunction.
The device is losing water in cooling mode.	The condensate tray is clogged.	Slowly pour a bottle of water in the lower section of the battery to check the drainage; if necessary clean the tray and/or improve the slope of the drain pipe.
	The condensate discharge pipe does not have the slope required for correct drainage.	
The device generates excessive noise.	The connection pipes and the valves unit are not well insulated.	Check the pipe insulation.
	The fan touches the structure.	Verify
	The fan is unbalanced.	The unbalancing generates excessive machine vibrations: replace the fan.
	Check the filters cleanliness	Clean filters

CONFIGURATION ACCESSORIES

13.1 Shut-off valves

Normally, unit comes without any shut-off valve.

⚠ The 2-way and 3-way motorized valves are mandatory for the correct operation of the unit.

⚠ The motorized valve can be omitted, inside the unit, if there is a motorized valve in the distribution manifold of the system and connected to the regulation card of the unit.

⚠ 2-way or 3-way motorized valves are available as accessories, see chapter "Compatible accessories" [p. 12](#).

13.1.1 Connection with 2-way manual valve (I20205)

I20205II - 2-way manual valve

In case of choice for the 2-way manual valve:

- no electrical connection are necessary
- connect to the flow at the bottom

- | | |
|----|---------------------------|
| 1. | Unit |
| 2. | Water outlet pipe fitting |

- | | |
|----|--------------------------|
| 3. | Water inlet pipe fitting |
| 4. | Manual closing valve |

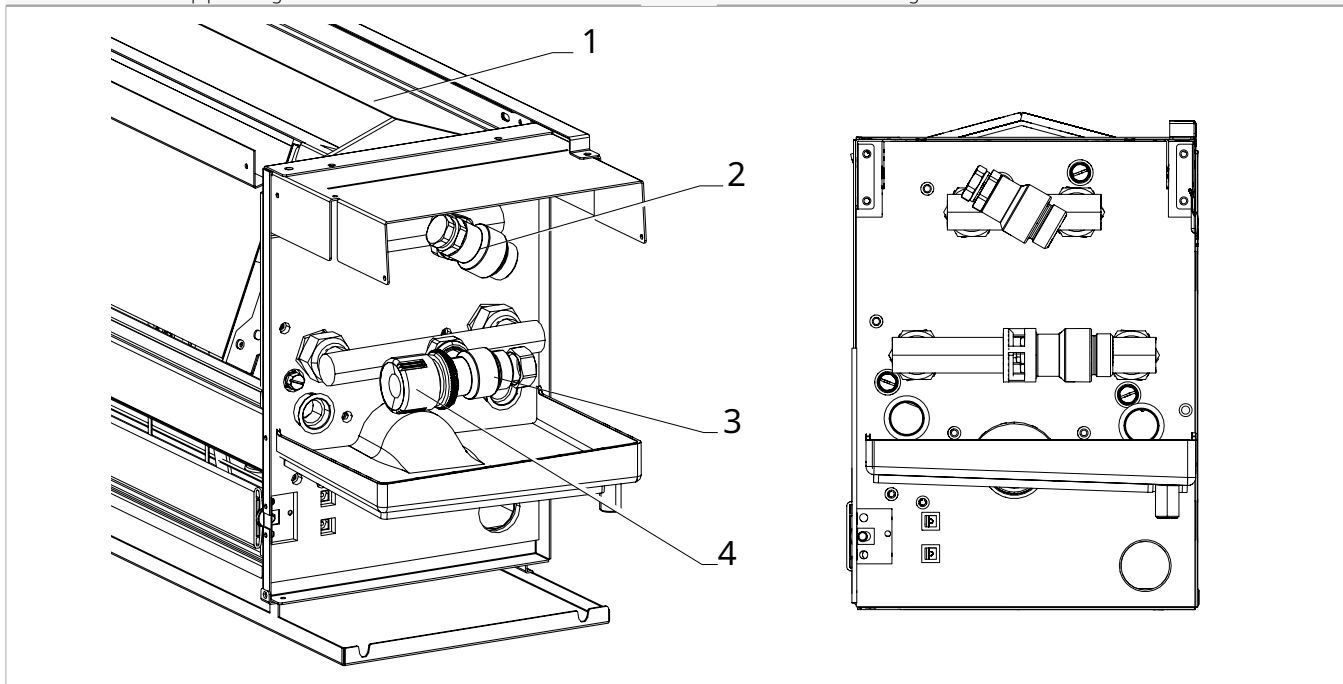

13.1.2 Connection with 2-way valve and thermoelectric actuator (V20687)

V20139II - 2 way valve group (water inlet valve, shut off valve and electro thermal motor)
 In case of choice for the 2-way valve and thermoelectric actuator:

electrical connection are required
 • connect to the flow at the bottom

- 1. Unit
- 2. Thermoelectric actuator
- 3. Water inlet pipe fitting

- 4. Water outlet pipe fitting
- 5. Electrical cable entry hole

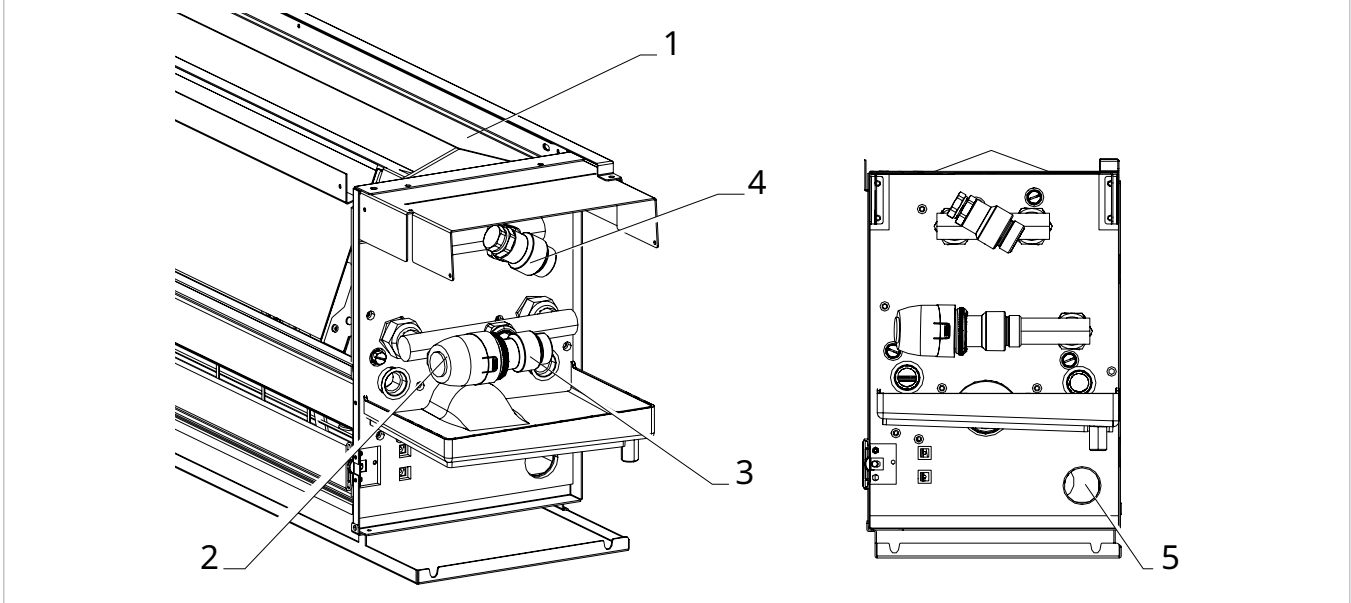

13.1.3 Connection with 3-way diverting valve unit with thermoelectric actuator (V30718)

V30718II - 3-way diverter valve group with thermoelectric motor (complete with 3-way inlet valve and lock-shield)
 In case of choice for the 3-way diverter valve unit with thermoelectric motor:

• electrical connection are required
 • connect to the flow at the bottom

- 1. Unit
- 2. Water outlet pipe fitting
- 3. Water inlet pipe fitting

- 4. Thermoelectric actuator
- 5. Electrical cable entry hole

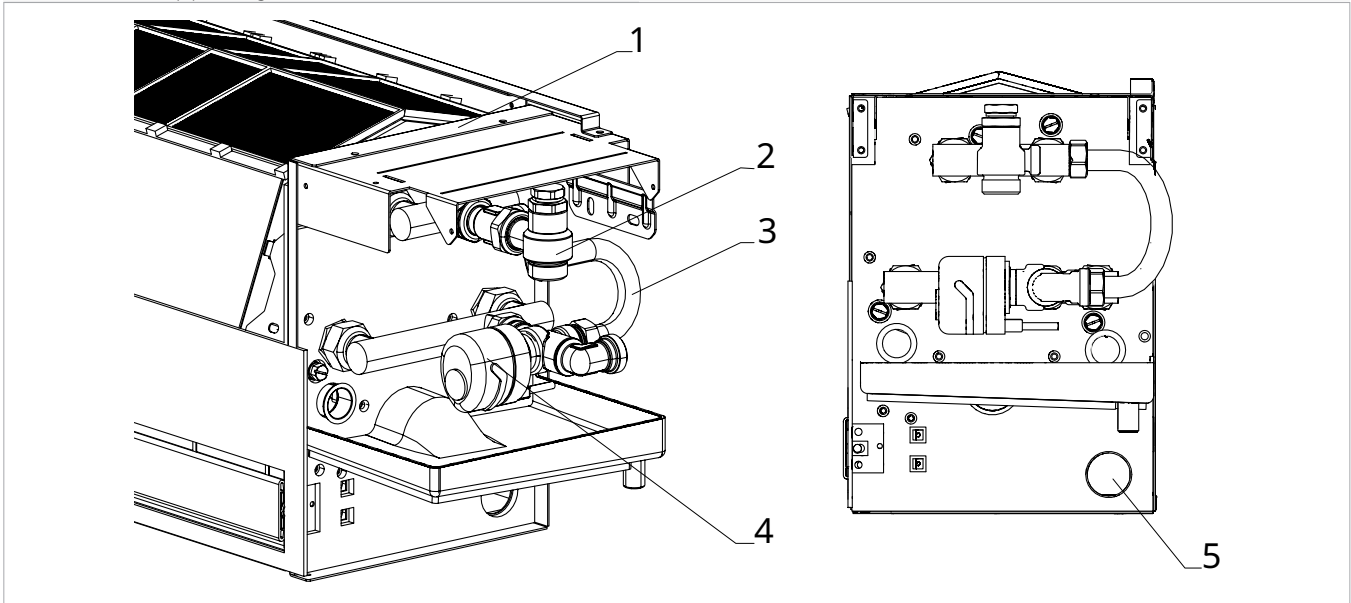

TECHNICAL INFORMATION

14.1 Technical data

		Filomuro Slim Fit	
Models	m.u.	800	
Cooling performances (W 7/12 °C; A 27 °C) (1)			
Total cooling capacity		kW	3,12
Sensible cooling capacity		kW	2,51
Water flow		L/h	674,00
Pressure drop		kPa	12,00
Maximum sound power level	(2)	dB(A)	62
Maximum absorbed power		W	52
Heating performances (W 45/40 °C; A 20 °C) (3)			
Heating capacity		kW	3,45
Water flow		L/h	801,00
Pressure drop		kPa	12,00
Maximum absorbed power		W	52
Maximum sound power level	(2)	dB(A)	62
Hydraulic data			
Coil water content		L	1,54
Hydraulic connections		" EK	3/4
Aeraulic data			
Maximum air flow		m ³ /h	788
Medium air flow		m ³ /h	480
Minimum flow rate		m ³ /h	230
Static pressure available		Pa	10
Electrical data			
Power supply		V/ph/Hz	230/1/50
Power consumption at the maximum speed		W	30,0
Maximum absorbed current		A	0,25
Sound data			
Sound pressure level at maximum air flow	(4)	dB(A)	51
Sound pressure level at medium air flow	(4)	dB(A)	37
Sound pressure level at minimum air flow	(4)	dB(A)	27
1. Water temperature in coil inlet 7 °C, Water temperature in coil outlet 12 °C, Room air temperature 27 °C b.s. and 19 °C b.u. (according to EN 1397) - maximum speed and head 0 Pa 2. Sound pressure measured according to EN 16583 3. Water temperature in coil inlet 45 °C, Water temperature at coil outlet 40 °C, Room air temperature 20 °C b.s. and 15 °C b.u. (according to EN 1397) - maximum speed and head 0 Pa 4. Sound pressure measured at a distance of 1 meter according to ISO 7779			

14.2 Dimensions

- A** Lateral view
- B** Front view

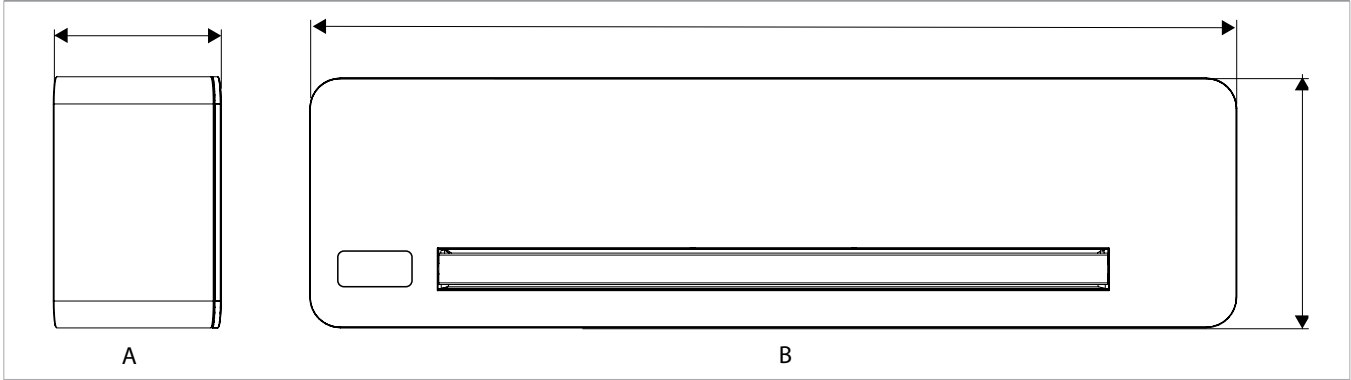

Models	m.u.	800	
Product dimensions and weight			
Width	mm	1245	
Height	mm	335	
Total depth	mm	215	
Net weight	kg	24,0	

14.3 Installation template

⚠ The units are supplied with a paper template for marking the holes necessary for installation.

Installation template

- | | |
|---|---|
| <ol style="list-style-type: none"> 1. Outlet for left hydraulic connections 2. Electrical connections zone for right installation 3. Prepare box for built for hydarulic flexible connections for left installation 4. Holes for dowels, Ø8 5. Minimum distance from the ceiling | <ol style="list-style-type: none"> 6. Top perimeter of the unit 7. Prepare box for built for hydarulic flexible connections for right installation 8. Electrical connections zone for left installation 9. Outlet for right hydraulic connections 10. Lower perimeter of the machine |
|---|---|

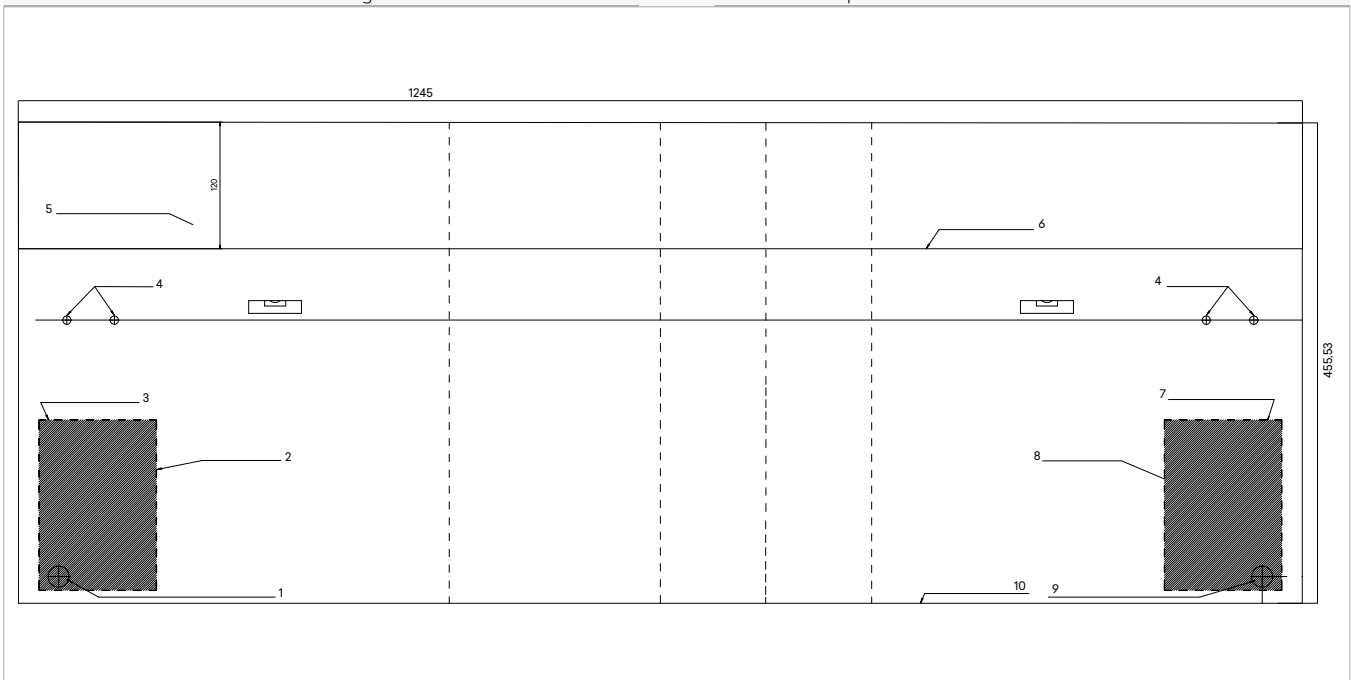



innova

INNOVA S.r.l.
Via I Maggio 8 - 38089 Storo (TN) - ITALY
tel. +39.0465.670104 - fax +39.0465.674965
info@innovaenergie.com